

22. Air Bubble Inside a Liquid

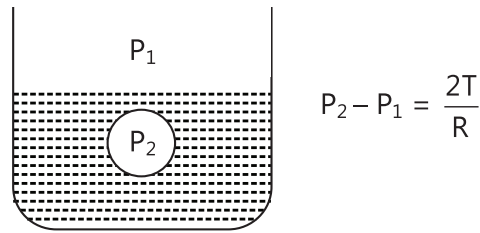

Figure 9.64

R – radius of bubble

T – surface tension force

23. Capillary Rise

$$h = \frac{2T \cos \theta}{r \rho g} \quad r \text{ is the radius of capillary tube}$$

θ = angle of contact

Solved Examples

JEE Main/Boards

Example 1: For the arrangement shown in the figure. What is the density of oil?

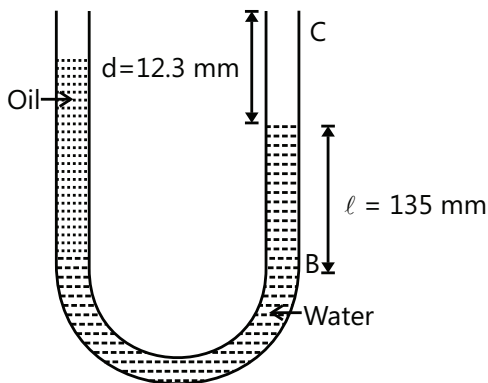

Sol: Pressure will be same at all points at the same height in the same liquid.

$$P_0 + \rho_w g l = P_0 + \rho_{oil} (\ell + d)g$$

$$\Rightarrow \rho_{oil} = \frac{\rho_w \ell}{\ell + d} = \frac{1000 \cdot (135)}{(135 + 12.3)} = 916 \text{ kg/m}^3$$

Example 2: A solid floats in a liquid of different material. Carry out an analysis to see whether the level of liquid in the container will rise or fall when the solid melts.

Sol: Level of liquid will rise or fall depending on the density of the solid.

Let M = Mass of the floating solid.

ρ_1 = density of liquid formed by the melting of the solid.

ρ_2 = density of the liquid in which the solid is floating. The mass of liquid displaced by the solid is M . Hence,

the volume of liquid displaced is $\frac{M}{\rho_2}$. When the solid

melts, the volume occupied by it is $\frac{M}{\rho_1}$. Hence, the level

of liquid in container will rise or fall according as

$\frac{M}{\rho_2} - \frac{M}{\rho_1}$ is less than or greater than zero.

\Rightarrow rises for $\rho_1 < \rho_2$

\Rightarrow falls for $\rho_1 > \rho_2$

There will be no change in the level if the level if $\rho_1 = \rho_2$. In case of ice floating in water $\rho_1 = \rho_2$ and hence, the level of water remains unchanged when ice melts.

Example 3: An iron casting containing a number of cavities weighs 6000 N in air and 4000 N in water. What

is the volume of the cavities in the casting? Density of iron is 7.87 g/cm^3 .

Take $g = 9.8 \text{ m/s}^2$ and density of water = 10^3 kg/m^3 .

Sol: Apply Archimedes principal. The volume of iron without the cavity is easily found. The total volume is found from the upthrust. The difference in volumes is the volume of cavity.

Let v be the volume of cavities and V the volume of solid iron. Then,

$$V = \frac{\text{mass}}{\text{density}} = \left(\frac{6000}{7.87 \times 10^3} \right) = 0.078 \text{ m}^3$$

Further, decrease in weight = upthrust

$$\therefore (6000 - 4000) = (V + v)\rho_w g$$

$$\text{or } 2000 = (0.078 + v) \times 10^3 \times 9.8$$

$$\text{or } 0.078 + v \approx 0.2$$

$$\therefore v = 0.12 \text{ m}^3$$

Example 4: A boat floating in a water tank is carrying a number of stones. If the stones were unloaded into water, what will happen to the water level?

Sol: When the stones are in boat they will displace more water as compared to the case when they are out of the boat and inside water.

Let weight of boat = W and weight of stone = w .

Assuming density of water = 1 g/cc

Volume of water displaced initially = $(w + W)/\rho_w$

$$\text{Later, Volume displaced} = \left(\frac{W}{\rho_w} + \frac{w}{\rho} \right)$$

(ρ = density of stones)

\Rightarrow Water level comes down.

Example 5: A conical glass capillary tube A of length 0.1 m has diameters 10^{-3} m and $5 \times 10^{-4} \text{ m}$ at the ends. When it is just immersed in a liquid at 0°C with larger radius in constant contact with it, the liquid rises to $8 \times 10^{-2} \text{ m}$ in the tube. In another cylindrical glass capillary tube B, when immersed in the same liquid at 0°C , the liquid rises to $6 \times 10^{-2} \text{ m}$ height. The rise of liquid in tube B is only $5.5 \times 10^{-2} \text{ m}$ when the liquid is at 50°C . Find the rate at which the surface tension changes with temperature considering the change to be linear. The density of liquid is $(1/4) \times 10^4 \text{ kg/m}^3$ and the angle of contact is zero. Effect of temp on the density of liquid and glass is negligible.

Sol: Use the formula for height of the liquid in the capillary.

Let r_1 and r_2 be radii of upper and lower ends of the conical capillary tube. The radius r at the meniscus is given by

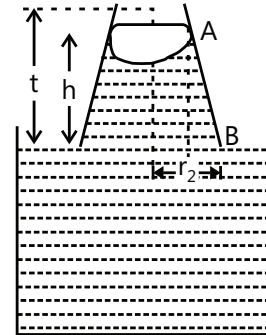

$$r = r_1 + (r_2 - r_1) \left(\frac{l - h}{l} \right)$$

$$= (2.5 \times 10^{-4}) + (2.5 \times 10^{-4}) \left(\frac{0.1 - 0.08}{0.1} \right)$$

$$= 3.0 \times 10^{-4} \text{ m}$$

The surface tension at 0°C is given by

$$T_0 = \frac{r h \rho g}{2}$$

$$= \frac{(3.0 \times 10^{-4})(8 \times 10^{-2})(1/4 \times 10^4) \times 9.8}{2} = 0.084$$

$$\text{For tube B, N/m } \frac{T_0}{T_{50}} = \frac{h_0}{h_{50}} = \frac{6 \times 10^{-2}}{5.5 \times 10^{-2}} = \frac{12}{11}$$

$$\Rightarrow T_0 = \frac{11}{12} \times T_{50} = \frac{11}{12} \times 0.084 = 0.077 \text{ N/m}$$

Considering the change in the surface tension as linear, the change in surface tension with temp is given by

$$\alpha = \frac{T_{50} - T_0}{T_0 - T_{50}} = \frac{0.077 - 0.084}{0.084 \times 0.077} = -\frac{1}{60} \text{ K}^{-1}$$

Negative sign shows that with rise in temp surface tension decreases.

Example 6: A piece of copper having an internal cavity weighs 264 gm in air and 221 gm when it is completely immersed in water. Find the volume of the cavity. The density of copper is 9.8 gm/cc .

Sol: Apply Archimedes principal. The volume of copper without the cavity is easily found. The total volume is found from the upthrust. The difference in volumes is

the volume of cavity.

Mass of copper in air = 264 gm

Mass of copper in water = 221 gm

Apparent loss of mass in water

$$= 264 - 221 = 43 \text{ gm}$$

∴ Mass of water displaced by copper piece when completely immersed in water is equal to 43 gm.

$$\text{Volume of water displaced} = \frac{\text{mass of displaced}}{\text{density of water}}$$

$$= \frac{43}{1.0} = 43.0 \text{ cc}$$

∴ Volume of copper piece including volume of cavity = 43.0 cc. Volume of copper block only

$$= \frac{\text{mass}}{\text{density}} = \frac{264}{8.8} = 30.0 \text{ cc}$$

$$\text{Volume of cavity} = 43.0 - 30.0 = 13.0 \text{ cc}$$

Example 7: A cubical block of each side equal to 10 cm is made of steel of density 7.8 gm/cm³. It floats on mercury surface in a vessel with its sides vertical. The density of mercury is 13.6 gm/cm³.

(a) Find the length of the block above mercury surface.

(b) If water is poured on the surface of mercury, find the height of the water column when water just covers the top of the steel block.

Sol: Apply Archimedes principal. The weight of the block will be equal to the weight of the liquid displaced.

(a) Volume of steel block

$$= (10)^3 = 1000 \text{ cm}^3$$

$$\text{Mass of steel block} = 1000 \times 7.8 = 7800 \text{ gm}$$

Let ℓ_1 be the height of steel block above the surface of mercury. Height of block under mercury = $10 - \ell_1$.

Weight of mercury displaced by block

$$= (10 - \ell_1) \times 100 \times 13.6 \times g \text{ gm}$$

Archimedes' principle shows that upward thrust is equal to the weight of mercury displaced by block is equal to the weight of the block.

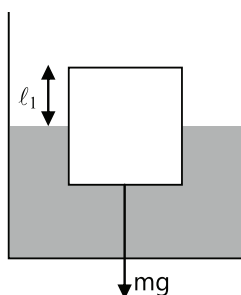

$$\therefore (10 - \ell_1) \times 100 \times 13.6 \times g = 7800 \text{ g}$$

$$10 - \ell_1 = \frac{7800}{100 \times 13.6} = 5.74$$

∴ length of block above mercury surface

$$= 10 - 5.74 = 4.26 \text{ cm}$$

(b) Let ℓ_2 be the height of water column above mercury surface so that water just covers the top of the steel block. The upward thrust due to mercury and water displaced is equal to the weight of the body

∴ weight of block = wt. of water displaced + wt. of mercury displaced

$$\therefore 7800 \text{ g} = \ell_2 \times 1000 \times 1 \times g$$

$$+ (10 - \ell_2) \times 100 \times 13.6 \times g$$

$$7800 = 100 \ell_2 + 13600 - 1360 \ell_2$$

$$1260 \ell_2 = 13600 - 7800 = 5800$$

∴ Height of water column above mercury =

$$\ell_2 = \frac{5800}{1260} = 4.6 \text{ cm}$$

Example 8: A cubical block of wood of each side 10 cm long floats at the interface between oil and water with its lower surface 2 cm below the interface. The height of oil and water column is 10 cm each. The density of oil is 0.8 g cm⁻³.

(a) What is the mass of the block?

(b) What is the pressure at the lower side of surface of block?

Sol: Apply Archimedes principle. The weight of the block will be equal to the weight of the liquid displaced.

(a) Buoyant force = (mass of liquid displaced) × g

$$= [10 \times 10 \times 8 \times 0.8 + 10 \times 10 \times 1]g = 840 \text{ g}$$

If m is mass of block

$$mg = 840 \text{ g} \quad \text{or} \quad m = 840 \text{ gm}$$

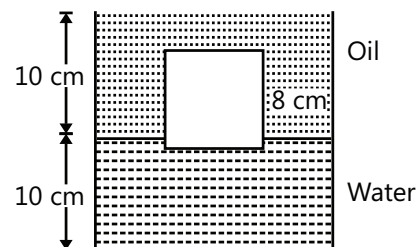

(b) Pressure at the lower surface of block

= pressure at any point on the same level.

$$10 \times 0.8 \times g + 2 \times 1 \times g$$

$$= 10g = 10 \times 9.81 = 99.1 \text{ Newton/meter}^2$$

Example 9: A massless smooth piston forces water with a velocity of 8 m/s out of a tube shaped container with radii 4.0 cm and 1.0 cm respectively as shown in the figure. Assume that the water leaving the container enters air at 1 atmospheric pressure. Find

(a) The velocity of the piston

(b) Force F applied to the piston.

Sol: Apply Bernoulli's Theorem at two points, one near the piston and the other at the end of the tube.

(a) Let F be the force applied horizontally such that v_1 is the velocity of water in tube A of radius 4.0 cm and v_2 equal to 8 m/s is the velocity of water out of tube B of radius 1.0 cm.

Let p_0 be atmospheric pressure.

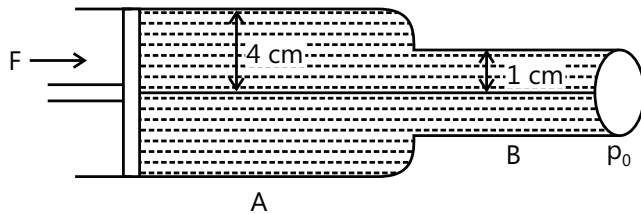

\therefore At A, $v_1 = ?$, $r_1 = 4.0$ cm, $p_1 = p_0 + \frac{F}{a}$ Where a is area of cross-section of piston or tube A. At B, $v_2 = 8$ m/s, $r_2 = 1.0$ cm, $p_2 = p_0$

Bernoulli's theorem sat A and B gives,

$$p_1 + \frac{1}{2}\rho v_1^2 + h\rho g = p_2 + \frac{1}{2}\rho v_2^2 + h\rho g$$

where ρ is density of water and h is height of axis of both tubes from ground level

$$\therefore p_1 + \frac{1}{2}\rho v_1^2 = p_2 + \frac{1}{2}\rho v_2^2$$

$$\frac{F}{a} + p_0 = p_0 + \frac{1}{2}\rho(v_2^2 - v_1^2)$$

$$\frac{F}{a} = \frac{\rho}{2}(v_2^2 - v_1^2) \quad \dots(i)$$

Equation of continuity at A and B gives

$$v_1 a_1 = v_2 a_2$$

$$\text{or } v_1 = v_2 \times \frac{\pi r_2^2}{\pi r_1^2} = 8 \times \left(\frac{1}{4}\right)^2 = 0.5 \text{ m/s}$$

(b) Equation (i) gives $F = \frac{\rho}{2}(v_2^2 - v_1^2) =$

$$\frac{\pi \times (4)^2 \times 1000}{2} \times \left[64 - \frac{1}{4}\right]$$

$$= \frac{1}{2} \times \frac{22}{7} \times 16 \times 1000 \times \frac{255}{4} = 160.3N$$

Example 10: A horizontal tube has different cross-sections at two points A and B. The diameter at A is 4.0 cm and that at B is 2 cm/ The two manometer arms are fixed at A and B. When a liquid of density 800 kg/m³ flows through the tube, the difference of pressure between the arms of two manometers is 8 cm. Calculate the rate of flow of tube liquid.

Sol: Apply Bernoulli's Theorem and equation of continuity.

From Bernoulli's principle:

$$p_1 + \frac{1}{2}\rho v_1^2 = p_2 + \frac{1}{2}\rho v_2^2$$

From the equation of continuity: $A_1 v_1 = A_2 v_2$

pressure difference: $p_1 - p_2 = h\rho g$

$$\text{These equations give } v_1 = A_2 \sqrt{\frac{2gh}{(A_1^2 - A_2^2)}}$$

Rate of flow of volume

$$V = A_1 v_1 = A_1 A_2 \sqrt{\frac{2gh}{(A_1^2 - A_2^2)}}$$

$$= \pi^2 (4 \times 10^{-4}) (1 \times 10^{-2}) \sqrt{\frac{2 \times 9.8 \times 8 \times 10^{-2}}{(4\pi \times 10^{-4})^2 - (\pi \times 10^{-4})^2}}$$

$$= 4.06 \times 10^{-4} \text{ m}^3/\text{s}$$

JEE Advanced/Boards

Example 1: Under isothermal condition two soap bubbles of radii a and b coalesce to form a single bubble of radius c . If the external pressure is p_0

$$\text{show that surface tension } T = \frac{p_0(c^3 - a^3 - b^3)}{4(a^2 + b^2 + c^2)}$$

Sol: Pressure inside the soap bubble is larger than that outside it by amount $4T/R$, where T is surface tension and R is its radius.

As we know that for a soap bubble, the excess pressure

$$is = \frac{4T}{r}. \text{ External pressure is } p_0$$

$$\therefore p_a = p_0 + \frac{4T}{a} \therefore p_b = p_0 + \frac{4T}{b} \text{ and}$$

$$p_c = p_0 + \frac{4T}{c}$$

$$\text{and } v_a = \frac{4}{3}\pi a^3, v_b = \frac{4}{3}\pi b^3 \text{ \& } v_c = \frac{4}{3}\pi c^3 \quad \dots(i)$$

Applying conservation of mass

$$n_a + n_b = n_c$$

$$\Rightarrow \frac{p_a v_a}{RT_a} + \frac{p_b v_b}{RT_b} = \frac{p_c v_c}{RT_c} \quad [\because pv = nRT \Rightarrow n = \frac{Pv}{RT}]$$

Since, temp is constant

i.e. $T_a = T_b = T_c$, so the expression reduces to

$$p_a v_a + p_b v_b = p_c v_c$$

with the help of equation (i), we have

$$\left(p_0 + \frac{4T}{a}\right)\left(\frac{4}{3}\pi a^3\right) + \left(p_0 + \frac{4T}{b}\right)\left(\frac{4}{3}\pi b^3\right)$$

$$= \left(p_0 + \frac{4T}{c}\right)\left(\frac{4}{3}\pi c^3\right)$$

$$\Rightarrow 4T(a^2 + b^2 - c^2) = p_0(c^3 - a^3 - b^3)$$

$$\Rightarrow T = \frac{p_0(c^3 - a^3 - b^3)}{4(a^2 + b^2 - c^2)}$$

Example 2: Two identical cylindrical vessels with their bases at the same level contain a liquid of density ρ . The height of liquid in one vessel is h_1 and that in the other vessel is h_2 . The areas of either base is A . What is the work done by gravity in equalizing the levels when the two vessels are connected.

Sol: Work done by gravity is equal to the loss in the gravitational potential energy.

The center of gravity of liquid column would be at height h_1 and h_2 respectively. A is area of cross-section.

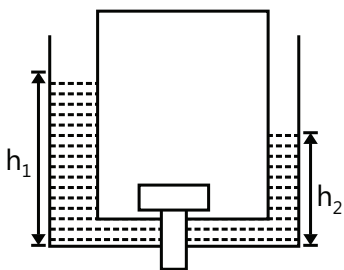

Total P.E. when they are not connected

$$Ah_1 \rho g \left(\frac{h_1}{2}\right) + Ah_2 \rho g \left(\frac{h_2}{2}\right) = A \rho g \left[\frac{h_1^2}{2} + \frac{h_2^2}{2}\right]$$

When the levels are equal, the potential energy is given as

$$= A \left(\frac{h_1 + h_2}{2}\right) \rho g \left(\frac{h_1 + h_2}{4}\right) + A \left(\frac{h_1 + h_2}{2}\right) \rho g \left(\frac{h_1 + h_2}{4}\right)$$

$$= 2A \rho g \frac{(h_1 + h_2)^2}{2 \times 4} = A \rho g \frac{(h_1 + h_2)^2}{4}$$

The change in potential energy

$$= \frac{A \rho g}{2} \left[\frac{(h_1 + h_2)^2}{2} - (h_1^2 - h_2^2)\right]$$

$$= \frac{A \rho g}{2} \left[\frac{h_1^2 + h_2^2 - 2h_1^2 - 2h_2^2 + 2h_1 h_2}{2}\right]$$

$$= \frac{A \rho g}{2} \left[\frac{-(h_1^2 + h_2^2 - 2h_1 h_2)}{2}\right]$$

$$\text{Work done due to gravity} = -A \rho g \left[\frac{h_1 - h_2}{2}\right]^2$$

The negative sign shows that the work is done by the gravitational field on the liquid.

Example 3: A container of large uniform cross-section area A resting on a horizontal surface holds two immiscible, non-viscous and incompressible liquids of densities d and $2d$, each of height $H/2$ as shown in figure. The lower density liquid is open to the atmosphere having pressure P_0 .

(a) A homogeneous solid cylinder of length L ($L < H/2$) and cross-section area $A/5$ is immersed such that, it floats with its axis vertical at the liquid-liquid interface with length $L/4$ in the dense liquid.

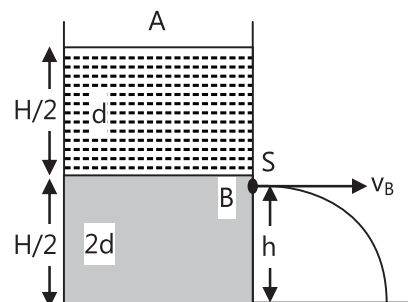

Determine:

- (i) The density D of the solid.
 - (ii) The total pressure at the bottom of the container.
- (b) The cylinder is removed and the original arrangement is restored. A tiny hole of area $S(S \ll A)$ is punched on the vertical side of the container at a height $h(h < H/2)$.

Determine:

- (i) The initial speed of efflux of liquid at the hole.
- (ii) The horizontal distance x travelled by the liquid initially.
- (iii) The height h_m at which the hole should be punched so that the liquid travels the maximum distance x_m initially. Also calculate x_m : (Neglect the air-resistance in these calculations)

Sol: Apply the principles of hydrostatic pressure, Archimedes and Bernoulli's Theorem.

(A) (i) As per Archimedes' principle, the buoyant force on a body is equal to the weight of the fluid displaced by the body.

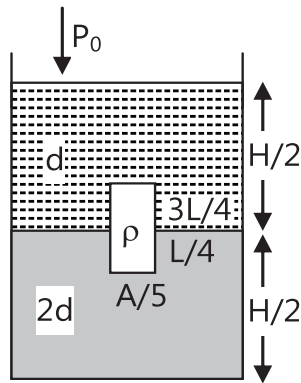

$$\text{Weight of solid cylinder} = L \times \frac{A}{5} \times D \times g = F \downarrow$$

$$F \uparrow = \text{Buoyant force} = \text{weight of liquid displaced}$$

$$= \frac{L}{4} \times \frac{A}{5} \times 2dg + \frac{3L}{4} \times \frac{A}{5} \times d \times g$$

$$\text{Equating: } L \times \frac{A}{5} \times D \times g$$

$$= \frac{L}{4} \times \frac{A}{5} \times 2dg + \frac{3L}{4} \times \frac{A}{5} \times d \times g$$

$$D = \frac{d}{2} + \frac{3d}{4} = \frac{2d + 3d}{4} = \frac{5d}{4}$$

(ii) Pressure at the bottom of the cylinder

$$= P_{\text{atmosphere}} + P_{\text{dense liquid}} + P_{\text{light liquid}}$$

$$\text{Pressure due to liquid} = \frac{\text{Force}}{\text{Area}}$$

$$= \frac{1}{A} \left[Adg \left(\frac{H}{2} \right) + A(2d)g \left(\frac{H}{2} \right) \right] = dg \left(\frac{3H}{2} \right)$$

Pressure due to buoyancy reaction

$$= \frac{\text{Buoyancy reaction force}}{\text{area}} = \left(\frac{A}{5} \right) \frac{LDg}{A}$$

$$= \frac{A}{5} \times L \times \frac{5d}{4} \times \frac{1}{A} \times g = \frac{Lgd}{4}$$

$$\therefore \text{Total pressure} = P_0 + dg \left(\frac{3H}{2} \right) + \frac{Lgd}{4}$$

$$= P_0 + dg \left[\frac{3H}{2} + \frac{L}{4} \right]$$

(b) (i) Let v_A and v_B be velocity of fluids at points A and B.

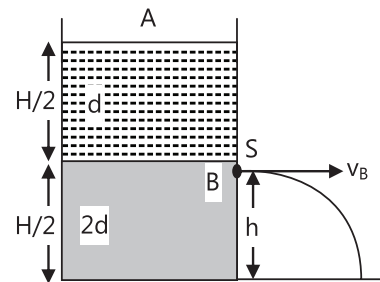

$$Av_A = sv_B$$

$$\therefore v_A = \left(\frac{s}{A} \right) v_B \approx 0 \quad (\because A \gg H/2)$$

$$\text{Bernoulli's Equation: } p + \frac{1}{2} \rho v_2^2 + \rho gh = \text{constant}$$

$$\text{At A, } P_0 + \frac{1}{2} \rho v_A^2 + dg \frac{H}{2} + 2d(g) \left(\frac{H}{2} \right) = \text{constant or}$$

$$P_0 + \frac{3}{2} dgH = \text{constant} (\because v_A = 0)$$

$$\text{At point B, } P_0 + \frac{1}{2} \rho v_A^2 + \frac{1}{2} (2d)v_B^2 + 2dgh = \text{constant}$$

$$\text{or } P_0 + dv_B^2 + 2dgh = \text{constant}$$

$$\text{Equating: } P_0 + dv_B^2 + 2dgh = P_0 + \frac{3}{2} dgH$$

$$dv_B^2 + 2dgh = \frac{3}{2} dgH$$

$$v_B^2 = g \left[\frac{3}{2} H - 2h \right]; v_B = \sqrt{g \left(\frac{3}{2} H - 2h \right)}$$

(ii) Time t taken by liquid to fall through height h under g with zero initial velocity. $t = \sqrt{\frac{2h}{g}}$

Horizontal distance

$$x = v_B t = \sqrt{\frac{2h}{g}} \times \sqrt{g \left(\frac{3H}{2} - 2h \right)}$$

$$\sqrt{h(3H - 4h)} = 2 \times \sqrt{h} \times \sqrt{\frac{3H}{4} - h}$$

(iii) To find height h at which x is max, $\frac{dx}{dh} = 0$.

$$\frac{d}{dh} [3Hh - 4h^2]^{1/2} = 0; \quad \frac{d}{dh} [h(3H - 4h)]^{1/2} = 0$$

$$\frac{d}{dh} \left[2 \times h \sqrt{\frac{3H}{4} - h} \right] = 0.$$

$$2 \times \frac{1}{2h} \left(\frac{3H}{4} - h \right)^{1/2} + 2\sqrt{h} \times \frac{1}{2} \left(\frac{3H}{4} - h \right)^{-1/2} (-1) = 0$$

$$\frac{1}{h} \left(\frac{3H}{4} - h \right)^{1/2} = \frac{\sqrt{h}}{\left[\frac{3H}{4} - h \right]^{1/2}}$$

$$\text{or } \frac{3H}{4} - h = h \text{ or } h = \frac{3}{8}H$$

$$\therefore x_m = 2 \times \sqrt{\frac{3H}{8}} \left(\frac{3H}{4} - \frac{3H}{8} \right)^{1/2}$$

$$= 2 \times \sqrt{\frac{3H}{8}} \times \sqrt{\frac{3H}{8}} = \frac{3H}{4}$$

Example 4: A tube of length ℓ and radius R carries a steady flow of liquid whose density is ρ and viscosity η .

The velocity v of flow is given by $V = V_0 \left(1 - \frac{r^2}{R^2} \right)$, where r is the distance of flowing fluid from the axis. Find

(a) Volume of fluid, flowing across the section of the tube, in unit time.

(b) Kinetic energy of the fluid within the volume of the tube.

(c) The frictional force exerted on the tube by the fluid, and

(d) The difference of pressures at the ends of the tube.

Sol: The cross section of tube can be thought of made-up of elementary rings of infinitesimal thickness. Find the volume flow rate and kinetic energy of one ring. Use the method of integration to find the flow rate and energy for the tube.

(a) Let us consider a cylindrical section at a distance of r and having thickness dr . The volume of fluid flowing through this section per second. $dv = (2\pi r dr) v_0 \left(1 - \frac{r^2}{R^2} \right)$

So, the volume of fluid flowing across the section of the tube in unit time.

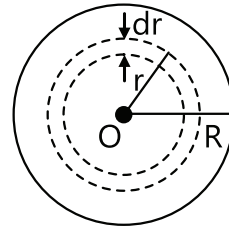

$$v = \int_0^R (2\pi r dr) v_0 \left(1 - \frac{r^2}{R^2} \right) = 2\pi v_0 \int_0^R r \left(1 - \frac{r^2}{R^2} \right) dr$$

$$= 2\pi v_0 \left[\frac{r^2}{2} - \frac{r^4}{4R^2} \right]_0^R = 2\pi v_0 \left(\frac{R^2}{4} \right)$$

(b) The kinetic energy of the fluid within the volume element of thickness dr

$$\frac{1}{2} (dm) v^2 = \frac{1}{2} (2\pi r dr \ell) \rho v_0^2 \left(1 - \frac{r^2}{R^2} \right)^2$$

So, the K.E. of fluid within the tube

$$= \frac{1}{2} (2\pi \ell) \rho v_0^2 \int_0^R \left(1 - \frac{r^2}{R^2} \right)^2 r dr$$

Integrating, we get

$$\text{K.E.} = \pi r \ell v_0^2 \left(\frac{R^2}{6} \right) \ell$$

(c) The viscous drag exerts a force on the tube

$$F = \eta A \left(\frac{dv}{dx} \right)_{r=R}$$

$$\text{Hence } \left(\frac{dv}{dr} \right)_{r=R} = v_0 \left(-\frac{2r}{R^2} \right)_{r=R} = \frac{-2v_0}{R}$$

$$\therefore F = -\eta (2\pi R \ell) \left(-\frac{2v_0}{R} \right) = 4\pi \eta h v_0$$

(d) The pressure difference ΔP is given by

$$\Delta P = P_2 - P_1 = P$$

Where $P_1 = 0$ and $P_2 = P$

As we know that $P = \frac{\text{Force}(F)}{\text{area of section of tube}}$

$$P = \frac{F}{\pi R^2} = \frac{4\pi\eta\ell v_0}{\pi R^2}$$

$$P = \frac{4\eta\ell v_0}{R^2}$$

Example 5: A fresh water reservoir is 10 m deep. A horizontal pipe 4.0 cm in diameter passes through the reservoir 6.0 m below the water surface as shown in figure. A plug secures the pipe opening.

(a) Find the friction force between the plug and pipe wall.

(b) The plug is removed. What volume of water flows out of the pipe in 1 h? Assume area of reservoir to be too large.

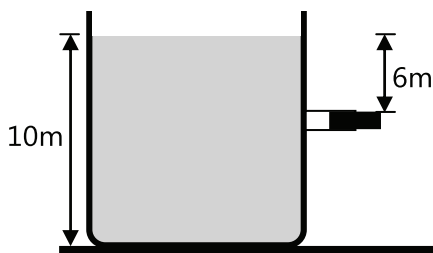

Sol: Force of friction will balance the force due to pressure difference on the plug. Use the formula for velocity of efflux for part (b)

(a) Force of friction

= pressure difference on the sides of the plug \times area of cross section of the plug

$$= (\rho gh) A = (10^3)(9.8)(6.0)(\pi)(2 \times 10^{-2})^2$$

$$= 73.9 \text{ N}$$

(b) Assuming the area of the reservoir to be too large.

Velocity of efflux $v = \sqrt{2gh} = \text{constant}$

$$\therefore v = \sqrt{2 \times 9.8 \times 6} = 10.84 \text{ m/s}$$

Volume of water coming out per sec,

$$\frac{dV}{dt} = Av = \pi(2 \times 10^{-2})^2(10.84) = 1.36 \times 10^{-2} \text{ m}^3 / \text{s}$$

\therefore The volume of water flowing through the pipe in 1 h.

$$V = \left(\frac{dV}{dt}\right)t = (1.36 \times 10^{-2})(3600) = 49.96 \text{ m}^3$$

Example 6: The U-tube acts as a water siphon. The bend in the tube is 1m above the water surface. The tube outlet is 7 m below the water surface. The water issues from the bottom of the siphon as a free jet at atmospheric pressure. Determine the speed of the free jet and the minimum absolute pressure of the water in the bend. Given atmospheric pressure = $1.01 \times 10^5 \text{ N/m}^2$.

$g = 9.8 \text{ m/s}^2$ and density of water = 10^3 kg/m^3 .

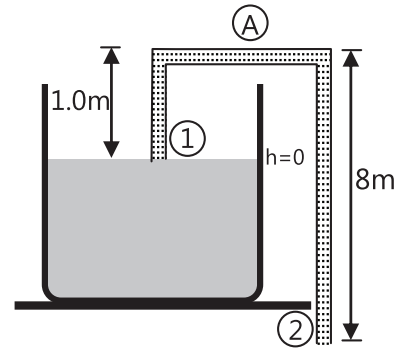

Sol: Apply Bernoulli's Theorem at points 1, A and 2.

(a) Applying Bernoulli's equation between point (1) and (2)

$$P_1 + \frac{1}{2}\rho v_1^2 + \rho h_1 + P_2 + \frac{1}{2}\rho v_2^2 + \rho gh_2$$

Since, area of reservoir \gg area of pipe

$$v_1 \approx 0, \quad \text{also } P_1 = P_2 = \text{atmospheric pressure}$$

$$\text{So, } v_1 = \sqrt{2g(h_1 - h_2)} = \sqrt{2 \times 9.8 \times 7} = 11.7 \text{ m/s}$$

(b) The minimum pressure in the bend will be at A. Therefore, applying Bernoulli's equation between (1) and (A)

$$P_1 + \frac{1}{2}\rho v_1^2 + \rho gh_1 = P_A + \frac{1}{2}\rho v_A^2 + \rho gh_A$$

Again, $v_1 \approx 0$ and from conservation of mass $v_A = v_2$;

$$P_A = P_1 + \rho g(h_1 - h_A) - \frac{1}{2}\rho v_2^2$$

Therefore, substituting the values, we have

$$P_A = (1.01 \times 10^5) + (1000)(9.8)(-1)$$

$$- \frac{1}{2} \times (1000)(11.7)^2 = 2.27 \times 10^4 \text{ N/m}^2$$

Example 7: Two separate air bubbles (radii 0.004 m and 0.002 m) formed of the same liquid (surface tension 0.07 N/m) come together to form a double bubble. Find the radius and the sense of curvature of the internal film surface common to both the bubbles.

Sol: Pressure inside the soap bubble is larger than that outside it by amount $4T/R$, where T is surface tension and R is its radius.

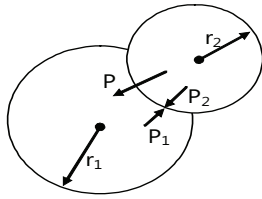

For the two bubbles,

$$P_1 = P_0 + \frac{4T}{r_1};$$

$$P_2 = P_0 + \frac{4T}{r_2}, \quad r_2 < r_1$$

$$\therefore P_2 > P_1$$

i.e. pressure inside the smaller bubble will be more. The excess pressure

$$P = P_2 - P_1 = 4T \left(\frac{r_1 - r_2}{r_1 r_2} \right) \quad \dots(i)$$

This excess pressure acts from concave to convex side, the interface will be concave towards smaller bubble and convex towards larger bubble. Let R be the radius of interface then,

$$P = \frac{4T}{R} \quad \dots(ii)$$

From equations (i) and (ii)

$$R = \frac{r_1 r_2}{r_1 - r_2} = \frac{(0.004)(0.002)}{(0.004 - 0.002)} = 0.004 \text{ m}$$

Example 8: A cylindrical tank of base area A has a small hole of area ' a ' at the bottom. At time $t = 0$, a tap starts to supply water into the tank at a constant rate $\alpha \text{ m}^3/\text{s}$.

(a) What is the maximum level of water h_{max} in the tank?

(b) Find the time when level of water becomes $h (< h_{\text{max}})$.

Sol: The height of water level will increase till the rate of inflow is greater than the rate of outflow. Use method of integration to find the time taken by water level to reach height h .

(a) Level will be maximum level when

Rate of inflow of water = rate of outflow of water

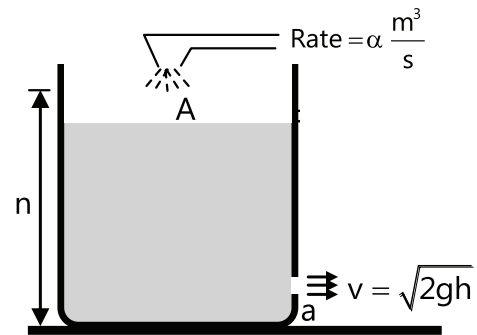

$$\text{i.e., } \alpha = av \text{ or } \alpha = a\sqrt{2gh_{\text{max}}}$$

$$\Rightarrow h_{\text{max}} = \frac{\alpha^2}{2ga^2}$$

(b) Let at time t , the level of water be h . Then,

$$A \left(\frac{dh}{dt} \right) = \alpha - a\sqrt{2gh} \text{ or } \int_0^h \frac{dh}{\alpha - a\sqrt{2gh}} = \int_0^t \frac{dt}{A}$$

Solving this, we get

$$t = \frac{A}{ag} \left[\frac{\alpha}{a} \ln \left\{ \frac{\alpha - a\sqrt{2gh}}{\alpha} \right\} - \sqrt{2gh} \right]$$

Example 9: Under isothermal condition, two soap bubbles of radii r_1 and r_2 coalesce to form a single bubble of radius r . The external pressure is P_0 . Find the surface tension of the soap in terms of the given parameters.

Sol: Pressure inside the soap bubble is larger than that outside it by amount $4T/R$, where T is surface tension and R is its radius. Use ideal gas equation and the condition that the total number of moles of air is conserved.

As mass of the air is conserved,

$$\therefore n_1 + n_2 = n \quad (\text{as } PV = nRT)$$

$$\therefore \frac{P_1 V_1}{RT_1} + \frac{P_2 V_2}{RT_2} = \frac{PV}{RT}$$

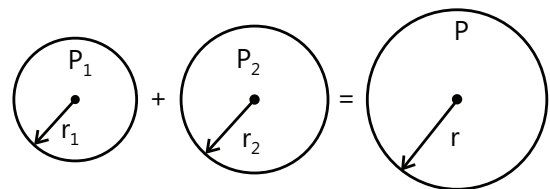

Although not given in the question, but we will have to assume that temperature of A and B are the same.

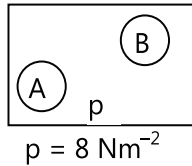

$$\frac{n_B}{n_A} = \frac{p_B V_B / RT}{p_A V_A / RT} = \frac{p_B V_B}{p_A V_A}$$

$$= \frac{(p + 4s / r_A) \times 4 / 3\pi(r_A)^3}{(p + 4s / r_B) \times 4 / 3\pi(r_B)^3}$$

(s = surface tension)

Substituting the values, we get $\frac{n_B}{n_A} = 6$

Example 10: A thin rod of length L and area of cross section S is pivoted at its lowest point P inside a stationary, homogeneous and non-viscous liquid as shown in the figure. The rod is free to rotate in a vertical plane about a horizontal axis passing through P. The density d_1 of the material of the rod is smaller than the density d_2 of the liquid. The rod is displaced by a small angle. From its equilibrium position and then released, show that the motion of the rod is simple harmonic and determine its angular frequency in terms of the given parameters.

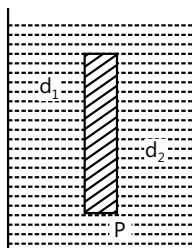

Sol: Use the restoring torque method to find the angular frequency.

Consider the rod be displaced through an angle θ . The different forces on the rod are shown in the figure.

Weight of rod acting downward = $S L d_1 g = mg$

Buoyant force acting upwards = $S L d_2 g$

Net thrust acting on the rod upwards; $F = S L (d_2 - d_1)g$

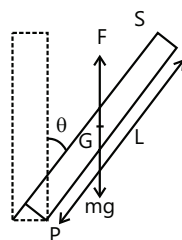

Restoring torque $\tau = Fx \frac{L}{2} \sin\theta = SL(d_2 - d_1)g \frac{L}{2} \sin\theta$

$\sin\theta \approx \theta$ (θ is small)

$$\therefore \tau = \frac{1}{2} SL^2 (d_2 - d_1) g \theta$$

$$\tau = I\alpha = \left(\frac{ML^2}{3} \right) \frac{d^2\theta}{dt^2} = \left(\frac{SLd_1 x L^2}{3} \right) \frac{d^2\theta}{dt^2}$$

$$\therefore \frac{d^2\theta}{dt^2} = \frac{3}{SL^3 d_1} \times \frac{1}{2} SL^2 (d_2 - d_1) g \theta$$

or $\frac{d^2\theta}{dt^2} = \frac{3g}{2L} \left(\frac{d_2 - d_1}{d_1} \right) \theta$; so motion is S.H.M;

comparing with differential equation of S.H.M.

$$\frac{d^2\theta}{dt^2} + \omega^2\theta = 0; \quad \omega = \sqrt{\frac{3g}{2L} \left(\frac{d_2 - d_1}{d_1} \right)}$$

$$\text{Timeperiod, } T = \frac{2\pi}{\omega} = 2\pi \sqrt{\frac{2Ld_1}{3g(d_2 - d_1)}}$$

Example 11: Two non-viscous, incompressible and immiscible liquids of density ρ and 1.5ρ are poured into two limbs of a circular tube of radius R and small cross-section kept fixed in a vertical plane as shown in the figure.

Each liquid occupies one fourth the circumference of the tube.

(a) Find the angle that the radius vector to the interface makes with the vertical in the equilibrium position.

(b) If the whole liquid is given a small displacement from its equilibrium position, show that the resulting oscillations are simple harmonic. Find the time period of these oscillations.

Sol: Use the restoring torque method to find the angular frequency.

(a) Density of liquid column BC = 1.5ρ ;

Density of liquid column CD = ρ

Pressure at A due to liquid column BA = ρAB

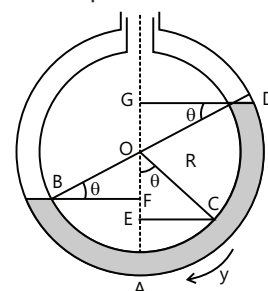

$$= AFx1.5\rho xg = (AO - OF)1.5\rho xg\rho$$

$$= (R - R\sin\theta)1.5g\rho$$

Pressure at A due to liquid column AD = ρAD
 $= AEx1.5\rho xg + EG\rho g$

$$\therefore \rho AD - (AO - OE)1.5g\rho + (EO + OG)\rho g$$

$$-(R - R\cos\theta)1.5g\rho + R(\cos\theta + \sin\theta)\rho g$$

In equilibrium $P_{AB} = P_{AD}$

$$R(1 - \sin\theta)1.5g\rho = R(1 - \cos\theta)1.5g\rho + R(\cos\theta + \sin\theta)\rho g$$

$$\tan\theta = \frac{0.5}{2.5} = \frac{1}{5} \quad \text{or} \quad \tan^{-1}\left(\frac{1}{5}\right)$$

(b) If a is area of cross-section,

$$\text{length of each column} = \frac{2\pi R}{4} = \frac{\pi R}{2}$$

$$\text{Volume of each column} = \frac{\pi Ra}{2}$$

$$\text{Mass of column BC} = \frac{\pi Ra}{2} \times 1.5\rho$$

$$\text{Mass of column CD} = \frac{\pi Ra}{2} \times \rho$$

$$\text{M.I. of whole liquid about O} = \left(\frac{\pi Ra\rho}{2}\right)(1.5 + 1)R^2$$

$$\text{or } I = \frac{2.5\pi R^3 a\rho}{2}$$

Let y be small displacement toward left and θ be the angular displacement,

$$\theta = \frac{y}{R} \quad \text{or } y = R\theta, \quad \text{Angular acceleration} = \frac{d^2\theta}{dt^2},$$

$$\text{Torque about A} = I \frac{d^2\theta}{dt^2} = \frac{2.5\pi R^3 a\rho}{2} \left(\frac{d^2\theta}{dt^2}\right)$$

Restoring torque due to displaced liquid.

$$\tau_{\text{rest}} = -[ay \times 1.5g\rho + ayg\rho] \times R \cos\theta$$

$$= -2.5ayg\rho \times R \cos\theta = -2.5apgR^2 \cos\theta \theta$$

[$R \cos\theta$ is perpendicular distance of gravitational force from axis of rotation]

$$\text{Equating } \left(\frac{2.5\pi R^3 a\rho}{2}\right) \frac{d^2\theta}{dt^2} = -(2.5apgR^2 \cos\theta)\theta$$

$$\frac{d^2\theta}{dt^2} = -\left(\frac{2g \cos\theta}{\pi R}\right)\theta = -\omega^2\theta$$

As $\frac{2g \cos\theta}{\pi R}$ Acceleration is proportional to angular displacement and is directed towards mean position, the liquid undergoes SHM

$$T = \frac{2\pi}{\omega} = 2\pi \times \sqrt{\frac{\pi R}{2g \cos\theta}}$$

$$\text{As } \tan\theta = \frac{1}{5}, \quad \cos\theta = \frac{5}{\sqrt{26}}$$

$$T = 2\pi \sqrt{\frac{\pi R}{2 \times g \times \frac{5}{\sqrt{26}}}} = 2(\pi)^{\frac{3}{2}} \sqrt{\frac{R}{\left(\frac{10g}{\sqrt{26}}\right)}}$$

JEE Main/Boards

Exercise 1

Q.1 If water in one flask and castor oil in other are violently shaken and kept on a table, then which one will come to rest earlier?

Q.2 What is the acceleration of a body falling through a viscous medium after terminal velocity is reached?

Q.3 The liquid is flowing steadily through a tube of varying diameter. How are the velocity of liquid flow (V) in any portion and the diameter (D) of the tube in that portion related?

Q.4 How does the viscosity of gases depend upon temperature?

Q.5 Explain the effect of (i) density (ii) temperature and (iii) pressure on the viscosity of liquids and gases.

Q.6 Two equal drops of water falling through air with a steady velocity v . If the drops coalesced, what will be the new steady velocity?

Q.7 What is the viscous force on a drop of liquid of radius 0.2 mm moving with a constant velocity 4 cm s^{-1} through a medium of viscosity $1.8 \times 10^{-1} \text{ Nm}^{-2} \text{ s}$.

Q.8 Eight rain drops of radius 1 mm each falling downwards with a terminal velocity of 5 cm s^{-1} coalesce to form a bigger drop. Find the terminal velocity of bigger drop.

Q.9 The flow rate of water from a tap of diameter 1.25 cm is 0.48 L/min. The coefficient of viscosity of water is 10^{-3} Pa-s . After sometime, the flow rate is increased to 3 L/min. The coefficient of viscosity of water is 10^{-3} Pa-s . Characterize the flow.

Q.10 A block of wood is floating in a lake? What is apparent weight of the floating block?

Q.11 A block of wood is floating in a lake. What is apparent weight of the floating block?

Q.12 A body floats in a liquid contained in a beaker. The whole system shown in the figure falls freely under gravity. What is the up thrust on the body due to the liquid?

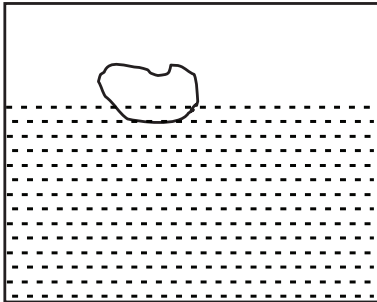

Q.13 A force of 60 N is applied on a nail, where tip has an area of cross-section of 0.0001 cm^2 . Find the pressure on the tip.

Q.14 If the water pressure gauge shows the pressure at ground floor to be 270 kPa, how high would water rise in the pipes of a building?

Q.15 A metal cube is 5 cm side and relative density 9, suspended by a thread is completely immersed in a liquid of density $1.2 \times 10^3 \text{ kg m}^{-3}$. Find the tension in the thread.

Q.16 A boat having a length of 3 m and breadth 2 m is floating on a lake. The boat sinks by one cm, when a man gets on it. What is the mass of the man?

Q.17 Calculate the force required to take away a flat plate of radius 5 cm from the surface of water. Given surface tension of water = $72 \times 10^{-3} \text{ Nm}^{-1}$.

Q.18 A square wire frame of side 10 cm is dipped in a liquid of surface tension $28 \times 10^{-3} \text{ Nm}^{-1}$. On taking out, a membrane is formed. What is the force acting on the surface of wire frame?

Q.19 The air pressure inside a soap bubble of diameter 3.5 mm is 8 mm of water above the atmosphere. Calculate the surface tension of soap solution.

Q.20 What should be the radius of the capillary tube so that water will rise to a height of 8 cm in it? Surface tension of water $70 \times 10^{-3} \text{ Nm}^{-1}$.

Exercise 2

Single Correct Choice Type

Q.1 The area of cross-section of the wider tube shown in figure is 800 cm^2 . If a mass of 12 kg is placed on the massless piston, the difference in heights h in the level of water in the two tubes is:

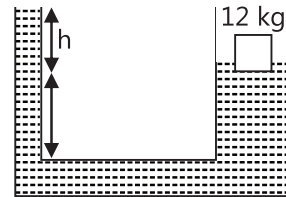

- (A) 10 cm (B) 6 cm (C) 15 cm (D) 2 cm

Q.2 Two cubes of size 1.0 m side, one of relative density 0.60 and another of relative density = 1.15 are connected by weightless wire and placed in a large tank of water. Under equilibrium the lighter cube will project above the water surface to a height of:

- (A) 50 cm (B) 25 cm (C) 10 cm (D) Zero

Q.3 A cuboidal piece of wood has dimensions a , b and c . Its relative density is d . It is floating in a large body of water such that side a is vertical. It is pushed down a bit and released. The time period of SHM executed by it is:

- (A) $2\pi\sqrt{\frac{abc}{g}}$ (B) $2\pi\sqrt{\frac{h}{da}}$
 (C) $2\pi\sqrt{\frac{bc}{dg}}$ (D) $2\pi\sqrt{\frac{da}{g}}$

Q.4 The frequency of a sonometer wire is f , but when the weights producing the tensions are completely immersed in water the frequency becomes $f/2$ and on immersing the weights in a certain liquid the frequency becomes $f/3$. The specific gravity of the liquid is:

- (A) $\frac{4}{3}$ (B) $\frac{16}{9}$ (C) $\frac{15}{12}$ (D) $\frac{32}{27}$

Q.5 A small ball of relative density 0.8 falls into water from a height of 2m. The depth to which the ball will sink is (neglect viscous forces):

- (A) 8 m (B) 2 m (C) 6 m (D) 4 m

Q.6 A hollow sphere of mass M and radius r is immersed in a tank of water (density ρ_w). The sphere would float if it were set free. The sphere is tied to the bottom of the tank by two wires which makes angle 45° with the horizontal as shown in figure. The tension T_1 in the wire is:

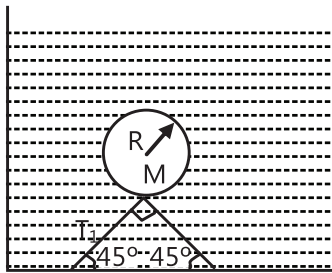

- (A) $\frac{4}{3} \frac{\pi R^3 \rho_w g - Mg}{\sqrt{2}}$ (B) $\frac{2}{3} \pi R^3 \rho_w g - Mg$
 (C) $\frac{4}{3} \frac{\pi R^3 \rho_w g - Mg}{2}$ (D) $\frac{4}{3} \pi R^3 \rho_w g - Mg$

Q.7 A large tank is filled with water to a height H . A small hole is made at the base of the tank. It takes T_1 times to decrease the height of water to H/η , ($\eta > 1$) and it takes T_2 time to take out the rest of water. If $T_1 = T_2$, then the value of η is:

- (A) 2 (B) 3 (C) 4 (D) 2.2

Q.8 In the case of a fluid, Bernoulli's theorem expresses the application of the principle of conservation of:

- (A) Linear momentum (B) Energy
 (C) Mass (D) Angular momentum

Q.9 Fountains usually seen in gardens are generated by a wide pipe with an enclosure at one end having many small holes. Consider one such fountain which is produced by a pipe of internal diameter 2 cm in which water flows at a rate 3 ms^{-1} . The enclosure has 100 holes each of diameter 0.05 cm. The velocity of water coming out of the holes is (in ms^{-1}):

- (A) 0.48 (B) 96 (C) 24 (D) 48

Q.10 A vertical tank open at the top, is filled with a liquid and rests on a smooth horizontal surface. A small hole is opened at the centre of one side of the tank. The area of cross-section of the tank is N times the area of the hole, where N is a large number. Neglect mass of the tank itself. The initial acceleration of the tank is:

- (A) $\frac{g}{2N}$ (B) $\frac{g}{\sqrt{2N}}$
 (C) $\frac{g}{N}$ (D) $\frac{g}{2\sqrt{N}}$

Q.11 Two water pipes P and Q having diameters $2 \times 10^{-2} \text{ m}$ and $4 \times 10^{-2} \text{ m}$, respectively, are joined in series with the main supply line of water. The velocity of water flowing in pipe P is:

- (A) 4 times that of Q (B) 2 times that of Q
 (C) 1/2 times that of Q (D) 1/4 times that of Q

Q.12 A rectangular tank is placed on a horizontal ground and is filled with water to a height H above the base. A small hole is made on one vertical side at a depth D below the level of the water in the tank. The distance x from the bottom of the tank at which the water jet from the tank will hit the ground is:

- (A) $2\sqrt{D(H-D)}$ (B) $2\sqrt{DH}$
 (C) $2\sqrt{D(H+D)}$ (D) $\frac{1}{2}\sqrt{DH}$

Q.13 A horizontal pipe line carries water in a streamline flow. At a point along the tube where the cross-sectional area is 10^{-2} m^2 , the water velocity is 2 ms^{-1} and the pressure is 8000 Pa. The pressure of water at another point where the cross-sectional area is $0.5 \times 10^{-2} \text{ m}^2$ is:

- (A) 4000 Pa (B) 1000 Pa
 (C) 2000 Pa (D) 3000 Pa

Q.14 Which of the following is not an assumption for an ideal fluid flow for which Bernoulli's principle is valid:

- (A) Steady flow
- (B) Incompressible
- (C) Viscous
- (D) Irrotational

Q.15 A solid metallic sphere of radius r is allowed to fall freely through air. If the frictional resistance due to air is proportional to the cross-sectional area and to the square of the velocity, then the terminal velocity of the sphere is proportional to which of the following?

- (A) r^2
- (B) r
- (C) $r^{3/2}$
- (D) $r^{1/2}$

Q.16 If two soap bubbles of different radii are connected by a tube.

- (A) Air flows from the bigger bubble to the smaller bubble till the sizes become equal
- (B) Air flows from bigger bubble to the smaller bubble till the sizes are interchanged
- (C) Air flows from the smaller bubble to the bigger
- (D) There is no flow of air

Q.17 A long capillary of radius r is initially just vertically completely immersed inside a liquid of angle of contact 0° . If the tube is slowly raised, then relation between radius of curvature of meniscus inside the capillary tube and displacement (h) of tube can be represented by:

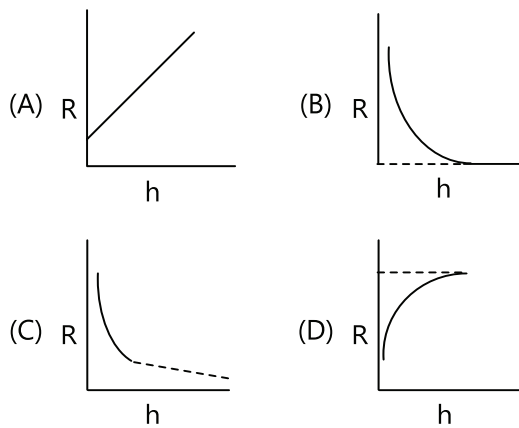

Q.18 Figure shows a siphon. Choose the wrong statement:

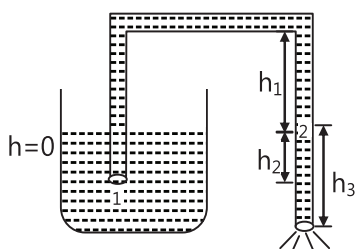

- (A) Siphon works when $h_3 > 0$
- (B) Pressure at point 2 is $P_2 = P_0 - \rho gh_3$
- (C) Pressure at point 3 is P_0
- (D) None of the above

Q.19 A steady flow of water passes along horizontal tube from a wide section X to the narrower section Y, see figure. Manometers are placed at P and Q of the sections. Which of the statements A,B,C,D is most correct?

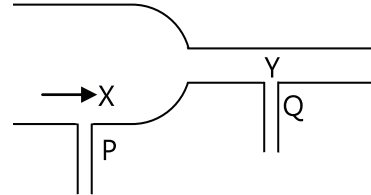

- (A) water velocity at X is greater than at Y
- (B) the manometer at P shows lower pressure than at Q
- (C) kinetic energy per m^3 of water at X = kinetic energy per m^3 at Y
- (D) the manometer at P shows greater pressure than at Y

Previous Years' Questions

Q.1 A metal ball immersed in alcohol weighs W_1 at $0^\circ C$ and W_2 at $50^\circ C$. The coefficient of cubical expansion of the metal is less than that of the alcohol. Assuming that the density of the metal is large compared to that of alcohol, it can be shown that: **(1980)**

- (A) $W_1 > W_2$
- (B) $W_1 = W_2$
- (C) $W_1 < W_2$
- (D) All of these

Q.2 A vessel containing water is given a constant acceleration a towards the right along a straight horizontal path. Which of the following diagrams represent the surface of the liquid? **(1981)**

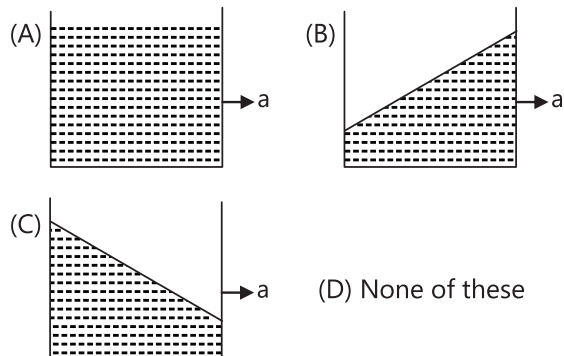

Q.3 A body floats in a liquid contained in a beaker. The whole system as shown in figure falls freely under gravity. The upthrust on the body due to the liquid is: **(1982)**

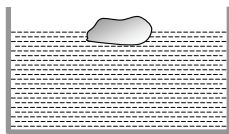

- (A) Zero
 (B) Equal to the weight of the liquid displaced
 (C) Equal to the weight of the body in air
 (D) Equal to the weight of the immersed position of the body

Q.4 A U-tube of uniform cross-section is partially filled with a liquid I. Another liquid II which does not mix with liquid I is poured into one side. It is found that the liquid levels of the two sides of the tube are the same, while the level of liquid I has risen by 2 cm. If specific gravity of liquid I is 1.1, the specific gravity of liquid II must be: **(1983)**

- (A) 1.12 (B) 1.1 (C) 1.05 (D) 1.0

Q.5 A homogeneous solid cylinder of length L . Cross-sectional area $A/5$ is immersed such that it floats with its axis vertical at the liquid-liquid interface with length $L/4$ in the denser liquid as shown in the fig. The lower density liquid is open to atmosphere having pressure p_0 . Then density D of solid is given by: **(1995)**

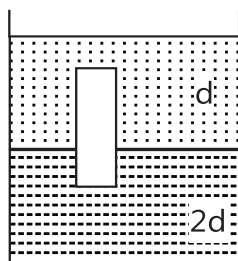

- (A) $\frac{5}{4}d$ (B) $\frac{4}{5}d$ (C) $4d$ (D) $\frac{d}{5}$

Q.6 Water from a tap emerges vertically downwards with an initial speed of 1.0 m/s. The cross-section area of the tap is 10^{-4}m^2 . Assume that the pressure is constant throughout the stream of water and that the flow is steady, the cross-sectional area of stream 0.15 m below the tap is: **(1998)**

- (A) $5.0 \times 10^{-4} \text{m}^2$ (B) $1.0 \times 10^{-4} \text{m}^2$
 (C) $5.0 \times 10^{-5} \text{m}^2$ (D) $2.0 \times 10^{-4} \text{m}^2$

Q.7 A large open tank has two holes in the wall. One is a square hole of side L at a depth y from the top and the other is a circular hole of radius R at a depth $4y$ from the top. When the tank is completely filled with water the quantities of water flowing out per second from both the holes are the same. Then R is equal to **(2000)**

- (A) $L / \sqrt{2\pi}$ (B) $2\pi L$
 (C) L (D) $L/2\pi$

Q.8 A wooden block, with a coin placed on its top, floats in water as shown in fig. The distance l and h are shown there. After some time the coin falls into the water. Then: **(2002)**

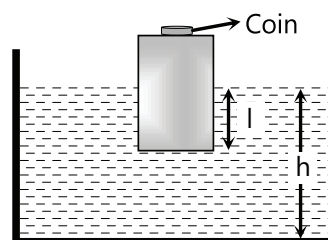

- (A) l Decreases and h increases
 (B) Increases and h decreases
 (C) Both l and h increase
 (D) Both l and h decrease

Q.9 Water is filled in a cylindrical container to a height of 3 m. The ratio of the cross-sectional area of the orifice and the beaker is 0.1. The square of the speed of the liquid coming out from the orifice is ($g = 10 \text{ m/s}^2$) **(2005)**

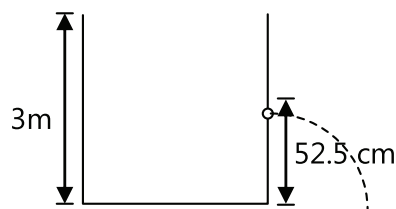

- (A) $50 \text{ m}^2/\text{s}^2$ (B) $50.5 \text{ m}^2/\text{s}^2$
 (C) $51 \text{ m}^2/\text{s}^2$ (D) $52 \text{ m}^2/\text{s}^2$

Q.10 A glass tube of uniform internal radius (r) has a valve separating the two identical ends. Initially, the valve is in a tightly closed position. End 1 has a hemispherical soap bubble of radius r . End 2 has sub-hemispherical soap bubble as shown in figure. **(2008)**

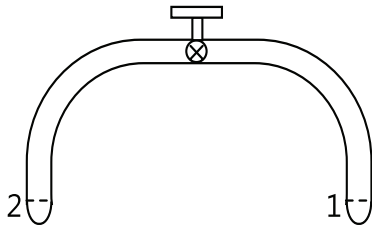

Just after opening the valve:

- (A) air from end 1 flow towards end 2. No change in the volume of the soap bubbles.
- (B) air from end 1 flows towards end 2. Volume of the soap bubble at end 1 decreases
- (C) no change occurs
- (D) air from end 2 flows towards end 1. Volume of the soap bubble at end 1 increases

Q.11 A uniform cylinder of length L and mass M having cross-sectional area A is suspended, with its length vertical, from a fixed point by a massless spring, such that it is half-submerged in a liquid of density ρ at equilibrium position. When the cylinder is given a small downward push and released it starts oscillating vertically with a small amplitude. If the force constant of the spring is k , the frequency of oscillation of the cylinder is **(1990)**

- (A) $\frac{1}{2\pi} \left(\frac{k - A\rho g}{M} \right)^{1/2}$
- (B) $\frac{1}{2\pi} \left(\frac{k + A\rho g}{M} \right)^{1/2}$
- (C) $\frac{1}{2\pi} \left(\frac{k + \rho g L^2}{M} \right)^{1/2}$
- (D) $\frac{1}{2\pi} \left(\frac{k + A\rho g}{A\rho g} \right)^{1/2}$

Q.12 A thin liquid film formed between a U-shaped wire and a light slider supports a weight of 1.5×10^{-2} N (see figure). The length of the slider is 30 cm and its weight negligible. The surface tension of the liquid film is **(2012)**

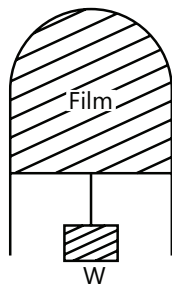

- (A) 0.0125 Nm^{-1}
- (B) 0.1 Nm^{-1}
- (C) 0.05 Nm^{-1}
- (D) 0.025 Nm^{-1}

Q.13 A uniform cylinder of length L and mass M having cross-sectional area A is suspended, with its length vertical, from a fixed point by a massless spring, such that it is half submersed in a liquid of density σ at equilibrium position. The extension x_0 of the spring when it is in equilibrium is: **(2013)**

- (A) $\frac{Mg}{k} \left(1 - \frac{LA\sigma}{M} \right)$
- (B) $\frac{Mg}{k} \left(1 - \frac{LA\sigma}{2M} \right)$
- (C) $\frac{Mg}{k} \left(1 + \frac{LA\sigma}{M} \right)$
- (D) $\frac{Mg}{k}$

(Here k is spring constant)

Q.14 Assume that a drop of liquid evaporates by decrease in its surface energy, so that its temperature remains unchanged. What should be the minimum radius of the drop for this to be possible? The surface tension is T , density of liquid is ρ and L is its latent heat of vaporization. **(2013)**

- (A) $\sqrt{T / \rho L}$
- (B) $T / \rho L$
- (C) $2T / \rho L$
- (D) $\rho L / T$

Q.15 An open glass tube is immersed in mercury in such a way that a length of 8 cm extends above the mercury level. The open end of the tube is then closed and sealed and the tube is raised vertically up by additional 46 cm. What will be length of the air column above mercury in the tube now? (Atmospheric pressure = 76 cm of Hg) **(2014)**

- (A) 38 cm
- (B) 6 cm
- (C) 16 cm
- (D) 22 cm

Q.16 On heating water, bubbles being formed at the bottom of the vessel detach and rise. Take the bubbles to be spheres of radius R and making a circular contact of radius r with the bottom of the vessel. If $r \ll R$, and the surface tension of water is T , value of r just before bubbles detach is: (density of water is ρ_w) **(2014)**

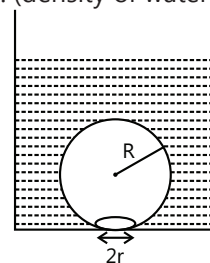

- (A) $R^2 \sqrt{\frac{\rho_w g}{T}}$
- (B) $R^2 \sqrt{\frac{3\rho_w g}{T}}$
- (C) $R^2 \sqrt{\frac{\rho_w g}{3T}}$
- (D) None of these

JEE Advanced/Boards

Exercise 1

Q.1 A piston of mass $M = 3 \text{ kg}$ and radius $R = 4 \text{ cm}$ has a hole into which a thin pipe of radius $r = 1 \text{ cm}$ is inserted. The piston can enter a cylinder tightly and without friction, and initially it is at the bottom of the cylinder. 750 gm of water is now poured into the pipe so that the piston and pipe are lifted up as shown. Find the height H of water in the cylinder and height h of water in pipe.

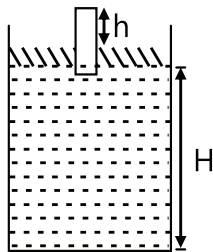

Q.2 A solid ball of density half of that of water falls freely under gravity from a height of 19.6m and then enters the water. Upto what depth will the ball go? How much time will it take to come again to the water surface? Neglect air resistance & velocity effects in water.

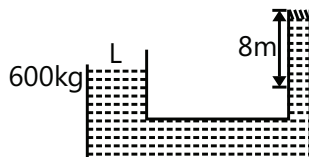

Q.3 For the system shown in the figure, the cylinder on left at L has a mass of 600 kg and a cross sectional area of 800 cm^2 . The piston on the right, at S, has cross sectional area 25 cm^2 and negligible weight. If the apparatus is filled with oil ($\rho = 0.75 \text{ gm/cm}^3$). Find the force F required to hold the system in equilibrium.

Q.4 (a) A spherical tank of 1.2 m radius is half filled with oil of relative density 0.9. If the tank is given a horizontal acceleration of 10 m/s^2 , calculate the inclination of the oil surface to horizontal and maximum gauge pressure on the tank.

(b) The volume of an air bubble is doubled as it rises from the bottom of a lake to its surface. If the atmospheric pressure is $H \text{ m}$ of mercury & the density of mercury is n times that of lake water, find the depth of the lake.

Q.5 A test tube of thin walls has lead shots in it at its bottom and the system floats vertically in water, sinking by a length $l = 10 \text{ cm}$. A liquid of density less than that of water, is poured into the tube till the levels inside and outside the tube are even. If the tube now sinks to a length $l = 40 \text{ cm}$, the specific gravity of the liquid is

Q.6 A large tank is filled with two liquids of specific gravities 2σ and σ . Two holes are made on the wall of the tank as shown. Find the ratio of distances from O of the points on the ground where the jets from holes A and B strike.

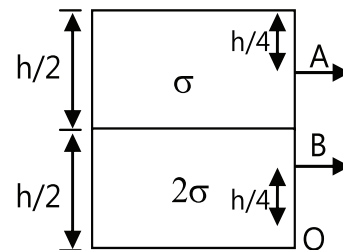

Q.7 A jet of water having velocity $= 10 \text{ m/s}$ and stream cross-section $= 2 \text{ cm}^2$ hits a plate perpendicularly, with the water splashing out parallel to plate. Find the force that the plate experiences.

Q.8 A laminar stream is flowing vertically down from a tap of cross-section area 1 cm^2 . At a distance 10 cm below the tap, the cross-section area of the stream has reduced to $1/2 \text{ m}^2$. Find the volumetric flow rate of water from the tap.

Q.9 A cylindrical vessel open at the top is 20 cm high and 10 cm in diameter. A circular hole whose cross-sectional area is 1 cm^2 is cut at the centre of the bottom of the vessel. Water flows from a tube above it into the vessel at the rate $100 \text{ cm}^3 \text{ s}^{-1}$. Find the height of water in the vessel under steady state.

Q.10 Calculate the rate of flow of glycerin of density $1.25 \times 10^3 \text{ kg/m}^3$ through the conical section of a 0.1m and 0.04m and the pressure drop across its length is 10 N/m^2 .

Q.11 A ball is given velocity v_0 (greater than the terminal velocity v_T) in downward direction inside a highly viscous liquid placed inside a large container. The height of liquid in the container is H . The ball attains

the terminal velocity just before striking at the bottom of the container. Draw graph between velocity of the ball and distance moved by the ball before getting terminal velocity.

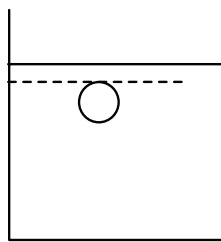

Q.12 A spherical ball of radius $1 \times 10^{-4} \text{m}$ and density 10^4 kg/m^3 falls freely under gravity through a distance h before entering a tank of water. If after entering the water the velocity of the ball does not change, find h . The viscosity of water is $9.8 \times 10^{-6} \text{ N-s/m}^2$.

Q.13 Two arms of a U-tube have unequal diameters $d_1 = 10 \text{ mm}$ and $d_2 = 1.0 \text{ cm}$. If water (surface tension $7 \times 10^{-2} \text{ N/m}$) is poured into the tube held in the vertical position, find the difference of level of water in the U-tube. Assume the angle of contact to be zero.

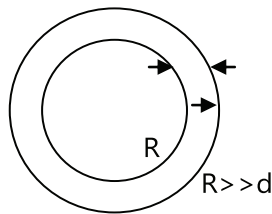

Q.14 A soap bubble has radius R and thickness $d (<< R)$ as shown. It collapses into a spherical drop. Find the ratio of excess pressure in the drop to the excess pressure inside the bubble.

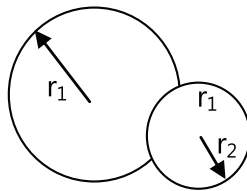

Q.15 Two soap bubbles with radii r_1 and r_2 ($r_1 > r_2$) come in contact. Their common surface has a radius curvature r .

Q.16 Place a glass beaker, partially filled with water, in a sink. The beaker has mass 390 gm and an interior volume of 500 cm^3 . You now start to fill the sink with water and you find, by experiment, that if the beaker is less than half full, it will float; but if it is more than half full, it remains on the bottom of the sink as the water

risers to its rim. What is the density of the material of which the beaker is made?

Q.17 A level controller is shown in the figure. It consists of a thin circular plug of diameter 10 cm and a cylindrical float of diameter 20 cm tied together with a light rigid rod of length 10 cm . The plug fits in snugly in a drain hole at the bottom of the tank which opens into the atmosphere. As water fills up and the level reaches height h , the plug opens. Find h . Determine the level of water in the tank when the plug closes again. The float has a mass 3 kg and the plug may be assumed as massless.

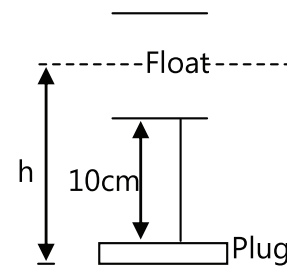

Q.18 A cylindrical rod of length $l=2 \text{ m}$ and density $\frac{\rho}{2}$ floats vertically in a liquid of density ρ as shown in fig. (a)

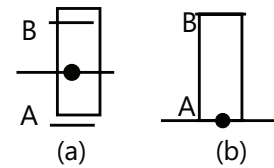

(a) Show that it performs SHM when pulled slightly up & released & find its time period. Neglect change in liquid level.

(b) Find the time taken by the rod to completely immerse when released from position shown in figure (b). Assume that it remains vertical throughout its motion.

(take $g = \pi^2 \text{ m/s}^2$)

Q.19 A thin rod of length L and area of cross-section S is pivoted at its lowest point P inside a stationary, homogeneous & non-viscous liquid (Figure). The rod is free to rotate in a vertical plane about a horizontal axis passing through P . the density d_1 of the material of the rod is smaller than the density d_2 of the liquid. The rod is displaced by a small angle θ from its equilibrium position and then released. Show that the motion of the rod is simple harmonic and determine its angular frequency in terms of the given parameters.

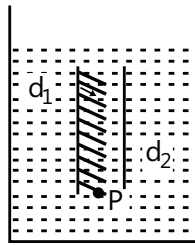

Q.20 A hollow cone floats with its axis vertical up to one-third liquid of its height in a liquid of relative density ρ is filled in it up to one-third of its height, the cone floats up to half its vertical height. The height of the cone is 0.10 m and the radius of the circular base is 0.05m. Find the specific gravity ρ .

Q.21 In the figure shown, the heavy cylinder (radius R) resting on a smooth surface separates two liquids of densities 2ρ and 3ρ . Find the height 'h' for the equilibrium of cylinder.

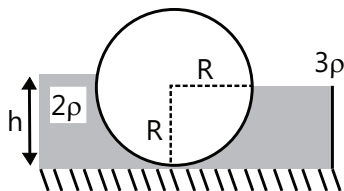

Q.22 The vertical limbs of a U shaped tube are filled with a liquid of density ρ up to a height h on each side. The horizontal portion of the U tube having length $2h$ contains a liquid of density 2ρ . The U tube is moved horizontally with an acceleration $g/2$ parallel to the horizontal arm. Find the difference in heights in liquid levels in the two vertical limbs, at steady state.

Q.23 A wooden stick of length l and radius R and density ρ has a small metal piece of mass m (of negligible volume) attached to its one end. Find the minimum value for the mass m (in terms of given parameters) that would make the stick float vertically in equilibrium in a liquid of density $\sigma (> \rho)$.

Q.24 A vertical cylindrical container of base area A and upper cross-section area A_1 making angle 30° with the horizontal placed in an open rainy field as shown near another cylindrical container having same base area A . Find the ratio of rates of collection of water in the two containers.

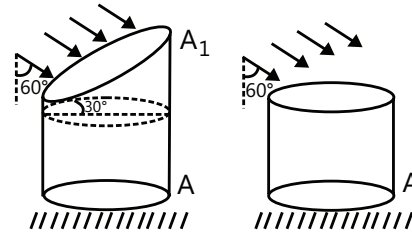

Q.25 A siphon has a uniform circular base of diameter $\frac{8}{\pi}$ cm with its crest A 1.8 m above water level as in figure. Find

- Velocity of flow.
- Discharge rate of the flow in m^3/sec .
- Absolute pressure at the crest level A .

[Use $P_0 = 10^5 \text{ N/m}^2$ & $g = 10 \text{ m/s}^2$]

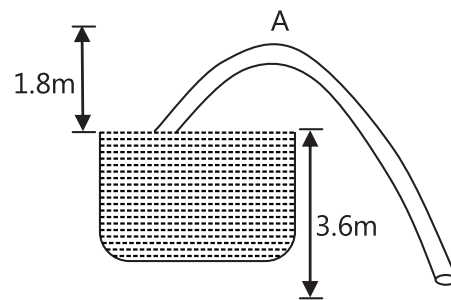

Q.26 Two very large open tanks A and F both contain the same liquid. A horizontal pipe BCD , having a constriction at C leads out of the bottom of tank A , and a vertical pipe E opens into the constriction at C and dips into the liquid in tank F . Assume streamline flow and no viscosity. If the cross section at C is one half that at D and if D is at a distance h_1 below the level of liquid in A , to what height h_2 (in terms of h_1) will liquid rise in pipe E ?

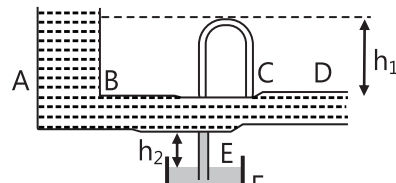

Q.27 A cube with mass 'm' completely wet by water floats on the surface of water. Each side of the cube is 'a'. What is the distance h between the lower face of cube and the surface of the water as ρ_w . Take angle of contact as zero.

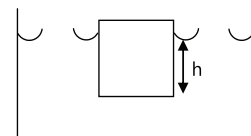

Exercise 2

Single Correct Choice Type

Q.1 A bucket contains water filled up to a height = 15cm. The bucket is tied to a rope which is passed on a frictionless light pulley and the other end of the rope is tied to a weight of mass which is half of that of the (bucket + water). The water pressure above atmosphere at the bottom is:

- (A) 0.5 kPa
- (B) 1 kPa
- (C) 5 kPa
- (D) None of these

Q.2 A cone of radius R and height H, is hanging inside a liquid of density ρ by means of a string as shown in the figure. The force, due to the liquid acting on the slant surface of the cone is (Neglect atmosphere pressure)

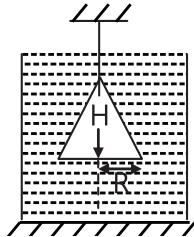

- (A) $\rho g H R^2$
- (B) $\rho \rho H R^2$
- (C) $\frac{4}{3} \rho g H R^2$
- (D) $\frac{2}{3} \rho g H R^2$

Q.3 An open cubical tank was initially fully filled with water. When the tank was accelerated on a horizontal plane along one of its side, it was found that one third of volume of water spilled out. The acceleration was:

- (A) $g/3$
- (B) $2g/3$
- (C) $3g/2$
- (D) None

Q.4 Some liquid is filled in a cylindrical vessel of radius R. Let F_1 be the force applied by the liquid on the bottom of the cylinder. Now the same liquid is poured into a vessel of uniform square cross-section of side R. Let F_2 be the force applied by the liquid on the bottom of this new vessel. (Neglect atmosphere pressure). Then:

- (A) $F_1 = \pi F_2$
- (B) $F_1 = F_2/p$
- (C) $F_1 = \sqrt{\pi} F_2$
- (D) $F_1 = F_2$

Q.5 A heavy hollow cone of radius R and height h is placed on a horizontal table surface, with its base on the table. The whole volume inside the cone is filled with water of density ρ . The circular rim of the cone's base has a water tight seal with the table's surface and

the top apex of the cone has a small hole. Neglecting atmospheric pressure, the total upward force exerted by water on the cone is:

- (A) $(\frac{2}{3})\rho R^2 h g$
- (B) $(\frac{1}{3})\rho R^2 h g$
- (C) $\rho R^2 h g$
- (D) None

Q.6 A slender homogeneous rod of length 2L floats partly immersed in water, being supported by a string fastened to one of its ends, as shown. The specific gravity of the rod is 0.75. The length of rod that extends out of water is:

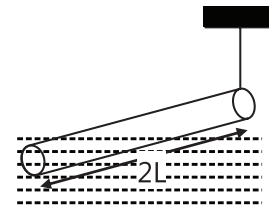

- (A) L^2
- (B) $L^2/2$
- (C) $L^2/4$
- (D) $3L^2/4$

Q.7 A dumbbell is placed in water of density ρ . It is observed that by attaching a mass m to the rod, the dumbbell floats with the rod horizontal on the surface of water and each sphere exactly half submerged as shown in the figure. The volume of the mass m is negligible. The value of length l is:

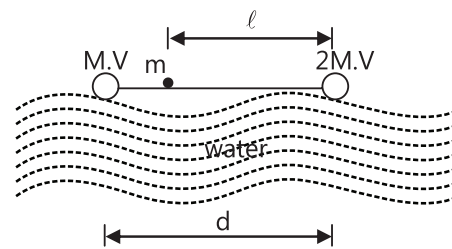

- (A) $\frac{d(V\rho - 3M)}{2(V\rho - 2M)}$
- (B) $\frac{d(V\rho - 2M)}{2(V\rho - 3M)}$
- (C) $\frac{d(V\rho + 2M)}{2(V\rho - 3M)}$
- (D) $\frac{d(V\rho - 2M)}{2(V\rho + 3M)}$

Q.8 A small wooden ball of density ρ is immersed in water of density σ to depth h and then released. The height H above the surface of water up to which the ball will jump out of water is:

- (A) $\frac{\sigma h}{\rho}$
- (B) $\left(\frac{\sigma}{\rho} - 1\right) h$
- (C) h
- (D) Zero

Q.9 A sphere of radius R and made of material of relative density σ has a concentric cavity of radius r . It just floats when placed in a tank full of water. The value of the ratio R/r will be:

- (A) $\left(\frac{\sigma}{\sigma-1}\right)^{1/3}$ (B) $\left(\frac{\sigma-1}{\sigma}\right)^{1/3}$
 (C) $\left(\frac{\sigma+1}{\sigma}\right)^{1/3}$ (D) $\left(\frac{\sigma-1}{\sigma+1}\right)^{1/3}$

Q.10 A fire hydrant delivers water of density ρ at a volume rate L . The water travels vertically upward through the hydrant and then does 90° turn to emerge horizontally at speed V . The pipe and nozzle have uniform cross-section throughout. The force exerted by the water on the corner of the hydrant is:

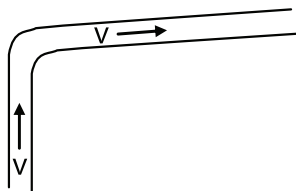

- (A) ρVL (B) Zero
 (C) $2\rho VL$ (D) $\sqrt{2} \rho VL$

Q.11 A cylindrical vessel filled with water up to height of H stands on a horizontal plane. The side wall of the vessel has a plugged circular hole touching the bottom. The coefficient of friction between the bottom of vessel and plane is μ and total mass of water plus vessel is M . What should be the minimum diameter of the hole so that the vessel begins to move on the floor if plug is removed (here density of water is ρ)

- (A) $\sqrt{\frac{2\mu M}{\pi\rho H}}$ (B) $\sqrt{\frac{\mu M}{2\pi\rho H}}$
 (C) $\sqrt{\frac{\mu M}{\rho H}}$ (D) None

Q.12 A Newtonian fluid fills the clearance between a shaft and a sleeve. When a force of 800N is applied to shift, parallel to the sleeve, the shaft attains of 1.5 cm/sec . If a force of 2.4 kN is applied instead, the shaft would move with a speed of

- (A) 1.5 cm/sec (B) 13.5 cm/sec
 (C) 4.5 cm/sec (D) None

Q.13 A cubical block of side 'a' and density ' ρ ' slides over a fixed inclined plane with constant velocity ' v '. There is a thin film of viscous fluid of thickness ' t ' between the plane and the block. Then the coefficient of viscosity of the thin film will be:

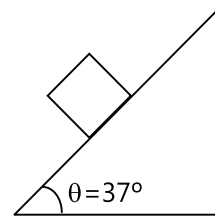

- (A) $\frac{3\rho a g t}{5v}$ (B) $\frac{4\rho a g t}{5v}$
 (C) $\frac{\rho a g t}{5v}$ (D) None of these

Q.14 Which of the following graphs best represent the motion of a raindrop?

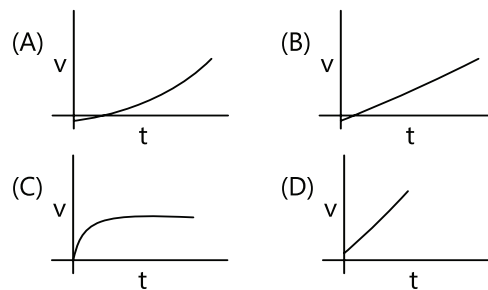

Q.15 Which of the following is the incorrect graph for a sphere falling in a viscous liquid? (Given at $t = 0$, velocity $v = 0$ and displacement $x = 0$)

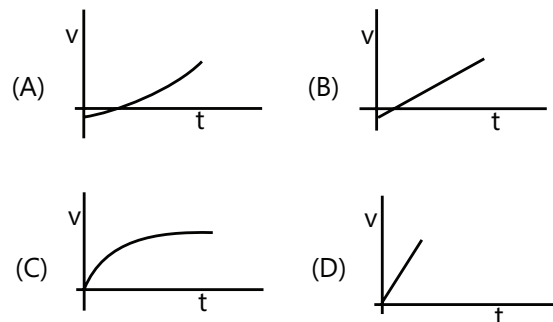

Q.16 A container, whose bottom has round holes with diameter 0.1 mm is filled with water. The maximum height in cm up to which water can be filled without leakage will be what?

Surface tension = $75 \times 10^{-3}\text{N/m}$ and $g = 10\text{ m/s}^2$:

- (A) 20 cm (B) 40 cm (C) 30 cm (D) 60 cm

Q.17 A liquid is filled in a spherical container of radius R till a height h . At this position the liquid surface at the edges is also horizontal. The contact angle is:

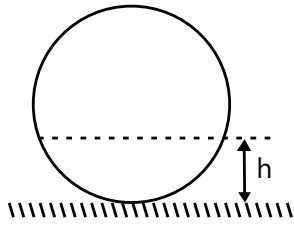

- (A) 0
 (B) $\cos^{-1}\left(\frac{R-h}{R}\right)$
 (C) $\cos^{-1}\left(\frac{h-R}{R}\right)$
 (D) $\sin^{-1}\left(\frac{R-h}{R}\right)$

Q.18 The vessel shown in the figure has two sections. The lower part is a rectangular vessel with area of cross-section A and height h . The upper part is a conical vessel of height h with base area ' A ' and top area ' a ' and the walls of the vessel are inclined at an angle 30° with the vertical. A liquid of density ρ fills both the sections up to a height $2h$. Neglecting atmospheric pressure,

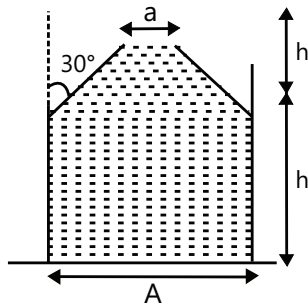

- (A) The force F exerted by the liquid on the base of the vessel is $2h\rho g \frac{(A+a)}{2}$
 (B) The pressure P at the base of the vessel is $2h\rho g \frac{A}{a}$
 (C) The weight of the liquid W is greater than the force exerted by the liquid on the base.
 (D) The walls of the vessel exert a downward force ($F-W$) on the liquid.

Multiple Correct Choice Type

Q.19 A cubical block of wood of edge 10 cm and mass 0.92 kg floats on a tank of water with oil of relative density 0.6 to a depth of 4 cm above water. When the block attains equilibrium with four of its side edges vertical,

- (A) 1 cm of it will be above the force of oil.

- (B) 5 cm of it will be under water.

- (C) 2 cm of it will be above the common surface of oil and water.

- (D) 8 cm of it will be under water.

Q.20 Water coming out of a horizontal tube at a speed v strikes normally a vertically wall close to the mouth of the tube and falls down vertically after impact. When is the speed of water increased to $2v$.

- (A) the thrust exerted by the water on the wall will be doubled.

- (B) the thrust exerted by the water on the wall will be four times

- (C) the energy lost per second by water striking the wall will also be four times

- (D) the energy lost per second by water striking the wall will be increased eight times.

Q.21 A beaker filled with water is accelerated $a \text{ m/s}^2$ in $+x$ direction. The surface of water shall make an angle:

- (A) $\tan^{-1}(a/g)$ backwards

- (B) \tan^{-1} draw of $(g/a)^1$

- (C) $\cot^{-1}(g/a)$ backwards

- (D) $\cot^{-1}(a/g)$ backwards

Q.22 The spring balance A read 2 kg with a block m suspended from it. A balance B reads 5 kg when a beaker with liquid is put on the pan of the balance. The two balances are now so arranged that the hanging mass is inside the liquid in the beaker as shown in the figure in this situation:

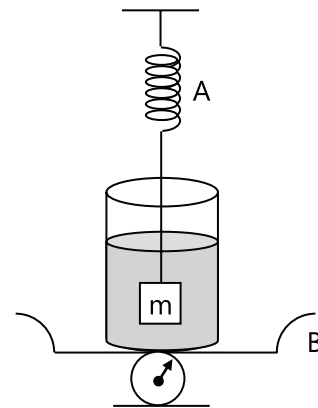

- (A) The balance A will read more than 2kg

- (B) The balance B will read more than 5 kg

(C) The balance A will read less than 2 kg and B will read more than 5 kg.

(D) The balance A and B will read 2 kg and 5 kg respectively

Q.23 When an air bubble rises from the bottom of a deep lake to a point just below the water surface, the pressure of air inside the bubble:

(A) Is greater than the pressure outside it

(B) Is less than the pressure outside it

(C) Increases as the bubble moves up

(D) Decreases as the bubble moves up

Q.24 A tank is filled up to a height h with a liquid and is placed on a platform of height h at a distance of y from the free surface of the liquid. Then

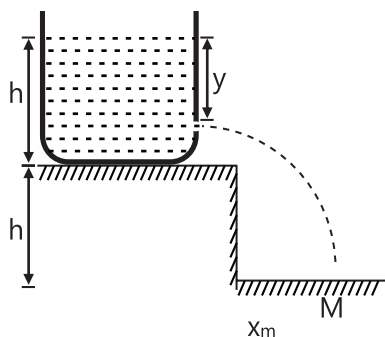

(A) $x_m = 2h$

(B) $x_m = 1.5h$

(C) $y = h$

(D) $y = 0.75h$

Assertion Reasoning Type

(A) Statement-I is true, statement-II is true and Statement-II is the correct explanation for statement-I

(B) Statement-I is true, statement-II is true and statement-II is NOT the correct explanation for statement-I

(C) Statement-I is true, statement-II is false.

(D) Statement-I is false, statement-II is true

Q.25 Statement-I: A helium filled balloon does not rise indefinitely in air but halts after a certain height.

Statement-II: Viscosity opposes the motion of balloon.

Q.26 Statement-I: A partly filled test tube is floating in a liquid as shown. The tube will remain as if its atmosphere pressure changes.

Statement-II: The buoyant force on a submerged object is independent of atmospheric pressure.

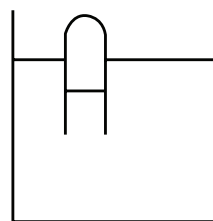

Q.27 Statement-I: Submarine sailors are advised that they should not be allowed to rest on floor of the ocean.

Statement-II: The force exerted by a liquid on a submerged body may be downwards.

Q.28 Statement-I: When a body floats such that its parts are immersed into two immiscible liquids then force exerted by liquid-1 is of magnitude $r_1 v_1 g$.

Statement-II: Total Bouyant force $r_1 v_1 g + r_2 v_2 g$.

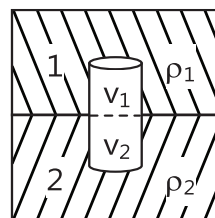

Q.29 Statement-I: When temperature rises the coefficient of viscosity of gases decreases.

Statement-II: Gases behave more like ideal gases at higher temperature.

Q.30 Statement-I: The free surface of a liquid at rest with respect to stationary container is always normal to the \vec{g}_{eff} .

Statement-II: Liquids at rest cannot have shear stress.

Previous Years' Questions

Q.1 A hemispherical portion of radius R is removed from the bottom of a cylinder of radius R . The volume of the remaining cylinder is V and mass M . It is suspended by a string in a liquid of density ρ , where it stays vertical. The upper surface of the cylinder is at a depth h below the liquid surface. The force on the bottom of the cylinder by the liquid is

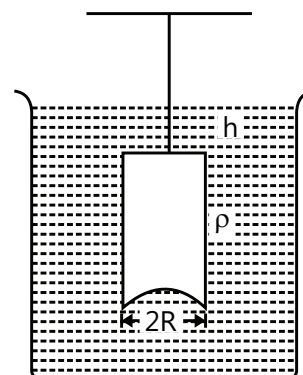

(2001)

- (A) Mg (B) $Mg - V\rho g$
 (C) $Mg + \rho R^2 h \rho R$ (D) $\rho g(V + \rho R^2 h)$

Q.2 When a block of iron floats in mercury at 0°C , fraction k_1 of its volume is submerged, while at the temperature 60°C , a fraction k_2 is seen to be submerged. If the coefficient of volume expansion of iron is γ_{Fe} and that of mercury is γ_{Hg} , then the ratio k_1/k_2 can be expressed as **(2001)**

- (A) $\frac{1 + 60\gamma_{\text{Fe}}}{1 + 60\gamma_{\text{Hg}}}$ (B) $\frac{1 - 60\gamma_{\text{Fe}}}{1 + 60\gamma_{\text{Hg}}}$
 (C) $\frac{1 + 60\gamma_{\text{Fe}}}{1 - 60\gamma_{\text{Hg}}}$ (D) $\frac{1 + 60\gamma_{\text{Hg}}}{1 + 60\gamma_{\text{Fe}}}$

Q.3 Water is filled up to a height h in a beaker of radius R as shown in the figure. The density of water is ρ , the surface tension of water is T and the atmospheric pressure is p_0 . Consider a vertical section ABCD of the water column through a diameter of the beaker. The force on water on one side of this section by water on the other side of this section has magnitude **(2007)**

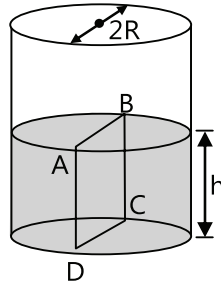

- (A) $|2p_0Rh + \pi R^2 \rho gh - 2RT|$
 (B) $|2p_0Rh + R\rho gh^2 - 2RT|$
 (C) $|p_0\pi R^2 + R\rho gh^2 - 2RT|$
 (D) $|p_0\pi R^2 + R\rho gh^2 - 2RT|$

Paragraph 1: (Q.4 - Q.6)

A wooden cylinder of diameter $4r$, height h and density $\rho/3$ is kept on a hole of diameter $2r$ of a tank, filled with liquid of density ρ as shown in the figure.

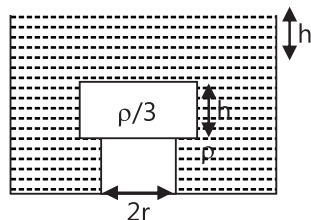

Q.4 Now level of the liquid starts decreasing slowly. When the level of liquid is at a height h_1 above the cylinder the block starts moving up. At what value of h_1 , will the block rise? **(2005)**

- (A) $4h/9$ (B) $5h/9$
 (C) $5h/3$ (D) Remains same

Q.5 The block in the above question is maintained at the position by external means and the level of liquid is lowered. The height h_2 when this external force reduces to zero is: **(2006)**

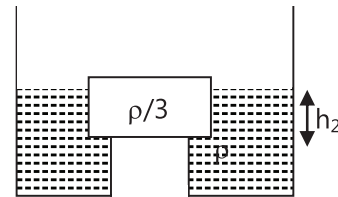

- (A) $\frac{4h}{9}$ (B) $\frac{5h}{9}$ (C) Remains same (D) $\frac{2h}{3}$

Q.6 If height h_2 of water level is further decreased, then: **(2006)**

- (A) cylinder will not move up and remains at its original position
 (B) for $h_2 = h/3$, cylinder again starts moving up
 (C) for $h_2 = h/4$, cylinder again starts moving up
 (D) $h_2 = h/5$, cylinder again starts moving up

Paragraph 2: (Q.7 - Q.9)

When a liquid medicine of density ρ is to be put in the eye, it is done with the help of a dropper. As the bulb on top of the dropper is pressed, a drop forms at the opening of the dropper. We wish to estimate the size of the drop.

We first assume that the drop formed at the opening is spherical because that requires minimum increase in its surface energy. To determine the size, we calculate the net vertical force due to the surface tension T when the radius of the drop is R . When this force becomes smaller than the weight of the drop, the drop gets detached from the dropper. **(2010)**

Q.7 If the radius of the opening of the dropper is r , the vertical force due to the surface tension on the drop of radius R (assuming $r \ll R$) is

- (A) $2\pi rT$ (B) $2\pi RT$ (C) $\frac{2\pi r^2 T}{R}$ (D) $\frac{2\pi R^2 T}{r}$

Q.8 If $r = 5 \times 10^{-4} \text{ m}$, $\rho = 10^3 \text{ kg m}^{-3}$, $g = 10 \text{ ms}^{-2}$, $T = 0.11 \text{ Nm}^{-1}$, the radius of the drop when it detaches from the dropper is approximately:

- (A) $1.4 \times 10^{-3} \text{ m}$ (B) $3.3 \times 10^{-3} \text{ m}$
 (C) $2.0 \times 10^{-3} \text{ m}$ (D) $4.1 \times 10^{-3} \text{ m}$

Q.9 After the drop detaches, its surface energy is:

- (A) $1.4 \times 10^{-6} \text{ J}$ (B) $2.7 \times 10^{-6} \text{ J}$
 (C) $5.4 \times 10^{-6} \text{ J}$ (D) $9.1 \times 10^{-9} \text{ J}$

Q.10 The spring A reads 2 kg with a block m suspended from it. A balance reads 5 kg when a beaker with liquid is put on the pan of the balance. The two balances are now so arranged that the hanging mass is inside the liquid in the beaker as shown in the figure. In this situation: **(1985)**

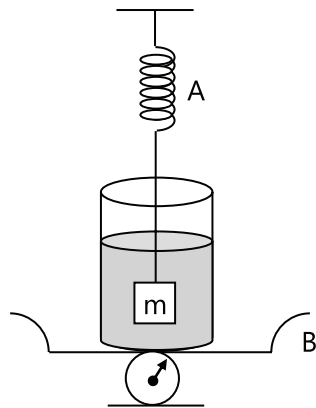

- (A) The balance A will read more than 2 kg
 (B) The balance A will read more than 5 kg
 (C) The balance A will read less than 2 kg and B will read more than 5 kg
 (D) The balances A and B will read 2 kg and 5 kg respectively.

Q.11 Two solid spheres A and B of equal volumes but of different densities d_A and d_B are connected by a string. They are fully immersed in a fluid of density d_F . They get arranged into the equilibrium state as shown in the figure with a tension in the string. The arrangement is possible only if

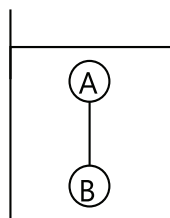

(2011)

- (A) $d_A < d_F$ (B) $d_B > d_F$
 (C) $d_A > d_F$ (D) $d_A + d_B = 2d_F$

Q.12 A thin uniform cylindrical shell, closed at both ends, is partially filled with water. It is floating vertically in water in half-submerged state. If ρ_c is the relative density of the material of the shell with respect to water, then the correct statement is that the shell is – **(2012)**

- (A) More than half-filled if ρ_c is less than 0.5
 (B) More than half-filled if ρ_c is less than 0.5
 (C) Half-filled if ρ_c is more than 0.5
 (D) Less than half – filled if ρ_c is less than 0.5

Q.13 A solid sphere of radius R and density ρ is attached to one end of a mass-less spring of force constant k . The other end of the spring is connected to another solid sphere of radius R and density 3ρ . The complete arrangement is placed in a liquid of density 2ρ and is allowed to reach equilibrium. The correct statement(s) is (are) **(2013)**

- (A) the net elongation of the spring is $\frac{4\pi R^3 \rho g}{3k}$
 (B) the net elongation of the spring is $\frac{8\pi R^3 \rho g}{3k}$
 (C) the light sphere is partially submerged.
 (D) the light sphere is completely submerged.

Paragraph for Questions 14 and 15

A spray gun is shown in the figure where a piston pushes air out of a nozzle. A thin tube of uniform cross section is connected to the nozzle. The other end of the tube is in a small liquid container. As the piston pushes air through the nozzle, the liquid from the container rises into the nozzle and is sprayed out. For the spray gun shown, the radii of the piston and the nozzle are 20 mm and 1 mm respectively. The upper end of the container is open to the atmosphere.

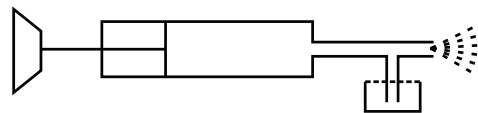

Q.14 If the piston is pushed at a speed of 5 mms^{-1} , the air comes out of the nozzle with a speed of **(2014)**

- (A) 0.1 ms^{-1} (B) 1 ms^{-1}
 (C) 2 ms^{-1} (D) 8 ms^{-1}

Q.15 If the density of air is ρ_a and that of the liquid ρ_ℓ , for a given piston speed the rate (volume per unit time) at which the liquid is sprayed will be proportional to **(2014)**

- (A) $\sqrt{\frac{\rho_a}{\rho_\ell}}$ (B) $\sqrt{\rho_a \rho_\ell}$
 (C) $\sqrt{\frac{\rho_\ell}{\rho_a}}$ (D) ρ_ℓ

Q.16 A person in a lift is holding a water jar, which has a small hole at the lower end of its side. When the lift is at rest, the water jet coming out of the hole hits the floor of the lift at a distance d of 1.2 m from the person.

In the following, state of the lift's motion is given in List I and the distance where the water jet hits the floor of the lift is given in List II. Match the statements from List I with those in List II and select the correct answer using the code given below the lists. **(2014)**

	List I		List II
1.	Lift is accelerating vertically up.	(p)	$d = 1.2$ m
2.	Lift is accelerating vertically down with an acceleration less than the gravitational acceleration.	(q)	$d > 1.2$ m
3.	Lift is moving vertically up with constant speed.	(r)	$d < 1.2$ m
4.	Lift is falling freely.	(s)	No water leaks out of the jar

Code:

- (A) 1 - q, 2 - r, 3 - q, 4 - s
 (B) 1 - q, 2 - r, 3 - p, 4 - s
 (C) 1 - p, 2 - p, 3 - p, 4 - s
 (D) 1 - q, 2 - r, 3 - p, 4 - p

Q.17 Two spheres P and Q of equal radii have densities ρ_1 and ρ_2 , respectively. The spheres are connected by a massless string and placed in liquids L_1 and L_2 of densities σ_1 and σ_2 and viscosities η_1 and η_2 , respectively. They float in equilibrium with the sphere P in L_1 and L₂ has terminal velocity \vec{V}_p and Q alone in L_1 has terminal velocity \vec{V}_Q , then **(2015)**

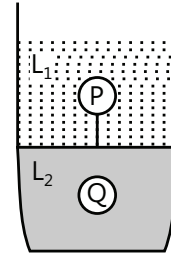

- (A) $\frac{|\vec{V}_p|}{|\vec{V}_Q|} = \frac{\eta_1}{\eta_2}$ (B) $\frac{|\vec{V}_p|}{|\vec{V}_Q|} = \frac{\eta_2}{\eta_1}$
 (C) $\vec{V}_p \cdot \vec{V}_Q > 0$ (D) $\vec{V}_p \cdot \vec{V}_Q < 0$

Q.18 A spherical body of radius R consists of a fluid of constant density and is in equilibrium under its own gravity. If $P(r)$ is the pressure at $r (r < R)$, then the correct option(s) is(are) **(2015)**

- (A) $P(r = 0) = 0$ (B) $\frac{P(r = 3R/4)}{P(r = 2R/3)} = \frac{63}{80}$
 (C) $\frac{P(r = 3R/5)}{P(r = 2R/5)} = \frac{16}{21}$ (D) $\frac{P(r = R/2)}{P(r = R/3)} = \frac{20}{27}$

Q.19 Consider two solid spheres P and Q each of density 8 gm cm^{-3} and diameters 1cm and 0.5cm, respectively. Sphere P is dropped into a liquid of density 0.8 gm cm^{-3} and viscosity $\eta = 3$ poiseulles. Sphere Q is dropped into a liquid of density 1.6 gm cm^{-3} and viscosity $\eta = 2$ poiseulles. The ratio of the terminal velocities of P and Q is **(2016)**

PlancEssential Questions

JEE Main/Boards

Exercise 1

Q. 7 Q.9 Q.15
Q.16 Q.20

Exercise 2

Q. 1 Q.7 Q.9
Q.13 Q.17

Previous Years' Questions

Q.8 Q.9 Q.10

JEE Advanced/Boards

Exercise 1

Q.3 Q.6 Q.9
Q.17

Exercise 2

Q.1 Q.4 Q.10
Q.11 Q.19 Q.22

Previous Years' Questions

Q.7 Q.8 Q.9

Answer Key

JEE Main/Boards

Exercise 1

Q.2 Zero	Q.6 $(2)^{2/3} v_T$	Q.7 2.714×10^{-9} m/s
Q.9 Streamline, turbulent	Q.10 Turbulent	Q.13 60×10^8 Pa
Q.14 27.6 m	Q.15 9.56 N	Q.16 60 kg
Q.17 $72\pi \times 10^{-4}$ N	Q.18 0.0224	Q.19 3.5×10^{-2} Nm ⁻¹
Q.20 1.785×10^{-4} m		

Exercise 2

Single Correct Choice Type

Q.1 C	Q.2 B	Q.3 D	Q.4 D	Q.5 A	Q.6 A
Q.7 C	Q.8 B	Q.9 D	Q.10 C	Q.11 A	Q.12 A
Q.13 C	Q.14 C	Q.15 D	Q.16 C	Q.17 B	Q.18 D
Q.19 D					

Previous Years' Questions

Q.1 C	Q.2 A	Q.3 A	Q.4 B	Q.5 A	Q.6 C
Q.7 A	Q.8 D	Q.9 A	Q.10 B	Q.11 B	Q.12 D
Q.13 B	Q.14 C	Q.15 C	Q.16 D		

JEE Advanced/Boards

Exercise 1

Q.1 $h = \frac{2m}{\pi}$, $H = \frac{11}{32\pi}m$

Q.2 19.6m, 4 sec.

Q.3 37.5 N

Q.4 (a) $9600\sqrt{2}$, (b) nH

Q.5 0.75

Q.6 $\sqrt{3} : \sqrt{2}$

Q.7 20N

Q.8 4.9 litre/min

Q.9 5 cm

Q.10 $6.43 \times 10^{-4} \text{ m}^3/\text{s}$

Q.11 velocity

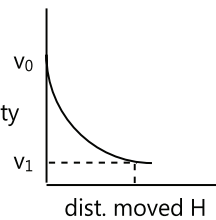

Q.14 $\left(\frac{R}{24d}\right)^{\frac{1}{3}}$

Q.12 20 m

Q.13 2.5 cm

Q.15 $r = \frac{r_1 r_2}{r_1 - r_2}$

Q.16 2.79 gm/cc

Q.17 $h_1 = \frac{2(3+\pi)}{15\pi} = 0.26$; $h_1 = \frac{3+\pi}{10\pi} = 0.195$

Q.18 2 sec., 1 sec

Q.19 $w = \sqrt{\frac{3g}{2L} \left(\frac{d_2 - d_1}{d_1}\right)}$

Q.20 1.9

Q.21 $R\sqrt{\frac{3}{2}}$

Q.22 $\frac{8h}{7}$

Q.23 $m_{\min} = \pi r^2 \ell (\sqrt{\rho\sigma} - \rho)$; if tilted then its axis should become vertical, C.M. should be lower than centre of buoyancy.

Q.24 2 : 1

Q.25 (a) $6\sqrt{2} \text{ m/s}$, (b) $9.6\sqrt{2} \times 10^{-3} \text{ M}^3 / \text{sec}$, (c) 4.6×10^4

Q.26 $h_2 = 3h_1$

Q.27 $h = \frac{mg + 4Sa}{\rho_w a^2 g}$

Exercise 2

Single Correct Choice Type

Q.1 B	Q.2 D	Q.3 B	Q.4 D	Q.5 A	Q.6 A
Q.7 B	Q.8 B	Q.9 A	Q.10 D	Q.11 A	Q.12 C
Q.13 A	Q.14 C	Q.15 C	Q.16 C	Q.17 B	Q.18 D

Multiple Correct Choice Type

Q.19 C, D Q.20 B, D Q.21 A, C Q.22 B, C Q.23 A, D Q.24 A, C

Assertion Reasoning Type

Q.25 B Q.26 D Q.27 A Q.28 D Q.29 D Q.30 A

Previous Years' Questions

Q.1 D Q.2 A Q.3 B Q.4 C Q.5 A Q.6 A
 Q.7 C Q.8 A Q.9 B Q.10 B, C Q.11 A, B, D Q.12 A
 Q.13 A, D Q.14 C Q.15 A Q.16 C Q.17 A, D Q.18 B, C

Solutions

JEE Main/Boards**Exercise 1**

Sol 1: Castor oil will come to rest first because its viscosity is greater than water

Sol 2: Acceleration is zero as velocity is constant

Sol 3: Flow rate is equal in any part of the body so

$$A_1 V_1 = \text{constant}$$

$$\pi \left(\frac{D}{2} \right)^2 V = \text{constant}$$

Sol 4: Viscosity of gas increases with increase in temperature

Sol 5: For gas, viscosity of gases are independent of density and pressure but viscosity of gas increases with increase in temperature

For liquids:- Viscosity decreases with increase in temperature. Viscosity increase with increase in density viscosity of liquid is normally independent of pressure, but liquid under extreme pressure after experience an increase in viscosity

Sol 6: Volume remains same so

$$2 \times \frac{4}{3} \pi r^3 = \frac{4}{3} \pi R^3$$

$$R = (2)^{1/3} r$$

$$V_T \propto r^2$$

$$\Rightarrow V'_T = k 2^{1/3} R^2 = (2)^{2/3} V_T$$

Sol 7: $r = 0.2 \text{ mm} = 2 \times 10^{-4} \text{ m}$

$$v = 4 \text{ cm/s} = 4 \times 10^{-2} \text{ m/s}$$

$$F = 6\pi \eta r v$$

$$= 6\pi \times 1.8 \times 10^{-5} \times 2 \times 10^{-4} \times 4 \times 10^{-2}$$

$$= 6\pi \times 14.4 \times 10^{-11} = 2.714 \times 10^{-9} \text{ m/s}$$

Sol 8: Refer Q-6 Exercise –I JEE Main

Sol 9: Critical velocity = $V_c = \frac{k\eta}{\rho r}$

$k = \text{Reynolds's number} = 1000$

$$V_c = \frac{1000 \times 10^{-3}}{1000 \times \frac{1.25}{200}} = \frac{1}{6.25} = 0.16 \text{ m/s}$$

$$Q = \text{flow rate} = 0.48 \text{ L/min} = \frac{0.8}{100} \text{ L/sec} = 8 \times 10^{-6} \text{ m}^3/\text{sec}$$

$$\text{Area} = \pi \left(\frac{1.25}{2} \right)^2 \times 10^{-4} = 1.227 \times 10^{-4}$$

$$\text{Velocity} = \frac{Q}{A} = \frac{8 \times 10^{-6}}{1.222 \times 10^{-4}}$$

$$= 6.5 \times 10^{-2} \text{ m/s}$$

$$V_1 < V_c \Rightarrow \text{Streamline}$$

When flow rate is 3L/min

$$Q' = 3\text{L/min} = \frac{3}{60} \text{ L/sec} = \frac{1}{20} \times 10^{-3} \text{ m}^3/\text{sec}$$

$$A = 1.227 \times 10^{-4}$$

$$V_2 = \frac{Q'}{A} = \frac{1 \times 10^{-3}}{20 \times 1.227 \times 10^{-4}}$$

$$= \frac{1}{2 \times 1.227} = 0.40 \text{ m/s}$$

$$V_2 > V_c \Rightarrow \text{turbulent flow}$$

Sol 10: Refer Q – 9 Exercise-I JEE Main

Sol 11: Apparent weight of the floating block is zero.

Sol 12: Up thrust will be zero as body is not exerting any force on water during free fall and there is no buoyant force

$$\text{Sol 13: Pressure} = \frac{F}{A} = \frac{60}{10^{-8}} = 60 \times 10^8 \text{ Pa}$$

$$\text{Sol 14: } 370 \times 10^3 = \rho gh + 10^5$$

$$\rho gh = (3.7-1) \times 10^5$$

$$h = \frac{2.7 \times 10^5}{9.8 \times 10^3} = 27.6 \text{ m}$$

Sol 15:

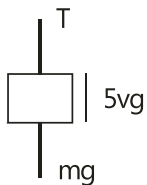

$$T = mg - \rho_w vg$$

$$= 9000 \times 125 \times 10^{-6} \times 9.8 - 1200 \times 125 \times 10^{-6} \times 9.8$$

$$= 7800 \times 125 \times 10^{-6} \times 9.8$$

$$= 7.8 \times 125 \times 10^{-3} \times 9.8 = 9.56 \text{ N}$$

Sol 16: Change in depth corresponds to mass of man

$$\rho \times 3 \times 2 \times \frac{1}{100} \times 10 = m \times 10$$

$$m = 1000 \times \frac{6}{100} = 60 \text{ kg}$$

Sol 17: Force = $2\pi r S$

$$= 2\pi \times \frac{5}{100} \times 72 \times 10^{-3}$$

$$= \pi \times 72 \times 10^{-4}$$

Sol 18: $F = 2 \times \text{perimeter} \times S$

$$= 2 \times 4 \times \frac{1}{10} \times 28 \times 10^{-3}$$

$$= 8 \times 28 \times 10^{-4}$$

$$= 0.0224$$

Sol 19: Pressure inside above atmospheric pressure

$$\rho gh = \frac{4T}{r}$$

$$10^4 \times 8 \times 10^{-3} = \frac{4T \times 2}{3.5 \times 10^{-3}}$$

$$T = 3.5 \times 10^{-2} \text{ Nm}^{-1}$$

$$\text{Sol 20: } h = \frac{2T}{r\rho g}$$

$$r = \frac{2 \times 70 \times 10^{-3}}{8 \times 10^{-2} \times 10^4}$$

$$= \frac{70}{4} \times 10^{-5} = 1.785 \times 10^{-4} \text{ m}$$

Exercise 2

Single Correct Choice Type

Sol 1: (C) Pressure due to difference in heights will be balanced by pressure due to 12 kg block

$$\Rightarrow \rho gh = \frac{120}{800 \times 10^{-4}}$$

$$10^4 h = \frac{120}{800} \times 10^4$$

$$h = \frac{12}{80} = \frac{3}{20} \text{ m} = 15 \text{ cm}$$

Sol 2: (B)

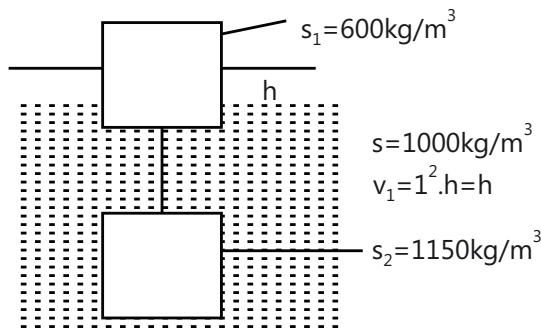

Downward force on the cubes = $(m_1 + m_2) g$
 $= \rho_1 Vg + \rho_2 Vg$
 $(1750) \times 10$
 Upward force on the cubes = $\rho(V_1 + V) g$
 $= 1000 (h + 1) \times 10$
 Since cubes are in equilibrium
 So $17500 = 10000 (h + 1)$
 $1.75 - 1 = h$
 $\Rightarrow h = 0.75 \text{ m}$

Sol 3: (D)

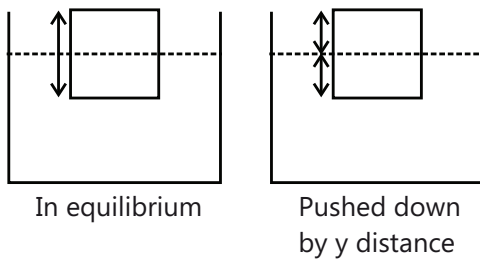

Initially in equilibrium
 When pushed down by y distance, an extra upward force will act on the cube
 $\rho (ybc) g = d \rho abc A$
 [A = acceleration of the cube]
 $y = \frac{da}{g} A \Rightarrow A = \frac{g}{da} y \Rightarrow \omega^2 = \frac{g}{da} \Rightarrow \omega = \sqrt{\frac{g}{da}} \Rightarrow T =$
 $\frac{2\pi}{\omega} = 2\pi \sqrt{\frac{da}{g}}$

Sol 4: (D) $f \propto \sqrt{T}$, T = tension in the wire
 in water frequency becomes $f/2$
 \Rightarrow Tension becomes $\frac{1}{4}$ of the initial
 in liquid frequency becomes $f/3$

\Rightarrow Tension become $1/9$ of the initial

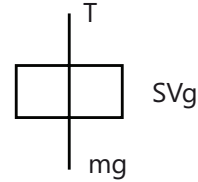

For water $\rho Vg = \frac{3mg}{4}$
 for liquid $d\rho Vg = \frac{8}{9} mg$
 $\Rightarrow d = \frac{8}{27} \times 4 = \frac{32}{27}$

Sol 5: (A) By work energy theorem

$W_{\text{water}} + W_{\text{gravity}} = \Delta KE = 0$
 $W_{\text{water}} = (\rho Vg) h$
 $W_{\text{gravity}} = -(0.8 \rho Vg) (h + 2)$
 $\Rightarrow \rho Vgh - 0.8 \rho Vg (h + 2) = 0$
 $h - 0.8 (h + 2) = 0 \Rightarrow \frac{5h}{4} = h + 2$
 $\frac{h}{4} = 2 \Rightarrow h = 8 \text{ m}$

Sol 6: (A) The vertical component of tension balances out the net of weight & buoyancy.

Sol 7: (C) We know that time taken for the vessel to

empty is $t_0 = \sqrt{\frac{2H}{g}}$, H = height of water
 Time taken to empty vessel of height $\frac{H}{\eta}$ is t_2
 $= \sqrt{\frac{2H}{g\eta}}$
 $t_1 = t_0 - t_2$ and $t_1 = t_2$
 $\Rightarrow \sqrt{\frac{2H}{g}} - \sqrt{\frac{2H}{g\eta}} = \sqrt{\frac{2H}{g\eta}} \Rightarrow \sqrt{\frac{2H}{g}} = 2\sqrt{\frac{2H}{g\eta}} \Rightarrow \eta = 4$

Sol 8: (B) Bernoulli's theorem is derived by the conservation of energy.

Sol 9: (D) Volume flow rate is same

So $\pi (1 \times 10^{-2})^2 \times 3$

$$= 100 \times \pi \left(\frac{0.05 \times 10^{-2}}{2} \right)^2 \times V$$

$$\pi \times 10^{-4} \times 3$$

$$= 100 \times \pi \times \frac{3}{4} \times 25 \times 10^{-8} \times V$$

$$V = \frac{4 \times 3}{25} \times 100 = 48$$

Sol 10: (C) We know that force exerted by fluid coming out on the container is ρAv^2

v = velocity of fluid

$$v = \sqrt{2g \frac{H}{2}}$$

A = area of the hole

$$\text{Acceleration of the tank} = \frac{\rho Av^2}{\rho(NAH)}$$

$$= \frac{\rho(AgH)}{\rho NAH} = \frac{g}{N}$$

Sol 11: (A) $A_1 V_1 = A_2 V_2$

$$\pi (10^{-2})^2 V_p = \pi (2 \times 10^{-2})^2 V_Q$$

$$V_p = 4V_Q$$

Sol 12: (A)

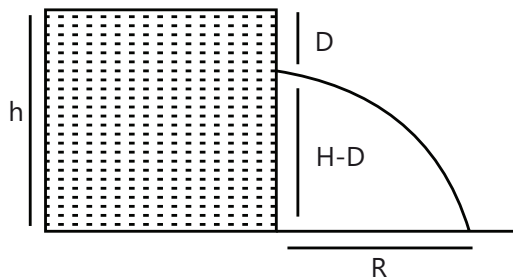

$$\text{Velocity of water} = \sqrt{2Dg}$$

Time taken by water to come to the ground

$$t = \sqrt{\frac{2(H-D)}{g}}$$

Distance where water hit the surface = vt

$$\sqrt{2Dg} \cdot \sqrt{\frac{2(H-D)}{g}} = 2\sqrt{D(H-d)}$$

Sol 13: (C) A = volume flow rate

$$= 10^{-2} \times 2 = 2 \times 10^{-2} \text{ m}^3/\text{s}$$

$$Q = A_1 v_1 = A_2 v_2$$

$$v_2 = \frac{Q}{A_2} = \frac{2 \times 10^{-2}}{1/2 \times 10^{-2}} = 4 \text{ m/s}$$

By Bernoulli equation

$$P_1 + \frac{1}{2} \rho v_1^2 = P_2 + \frac{1}{2} \rho v_2^2$$

$$8000 + \frac{1}{2} \times 1000 \times 4 = P_2 + \frac{1}{2} \times 1000 \times 16$$

$$10000 = P_2 + 8000$$

$$P_2 = 2000 \text{ Pa}$$

Sol 14: (C) Viscosity is not an assumption

Sol 15: (D) Frictional resistance $f \propto Av^2$

$$f = kAv^2 = k\pi r^2 v^2$$

k = constant

When ball acquires terminal velocity

$$f = mg$$

$$k\pi r^2 v^2 = mg$$

$$k\pi r^2 v^2 = (4/3 \pi r^3) \rho g$$

$$v^2 \propto r \Rightarrow v \propto r^{1/2}$$

Sol 16: (C)

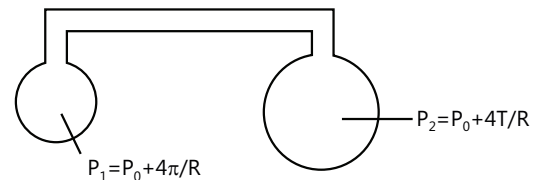

as $P_1 > P_2$ so air will flow out of the small bubble.

Sol 17: (B)

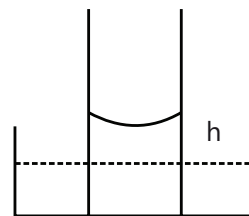

$$h = \frac{2T}{R\rho g}$$

R = radius of curvature

$$hR = \frac{2T}{\rho g} = \text{constant}$$

So graph of R vs. h will be hyperbola

Sol 18: (D) By Bernoulli equation

$$P_0 + \rho gh_3 = P_0 + \frac{1}{2} \rho v^2$$

$$\frac{1}{2} \rho v^2 = \rho gh_3$$

$$P_0 = P_2 + \frac{1}{2} \rho v^2$$

$$P_2 = P_0 - \rho gh_3$$

Sol 19: (D) By continuity

$$A_x V_x = A_y V_y$$

$$A_x > A_y$$

$$\Rightarrow v_x < v_y$$

By Bernoulli equation

$$P_x + \frac{1}{2} \rho v_x^2 = P_y + \frac{1}{2} \rho v_y^2$$

$$v_x < v_y$$

$$\Rightarrow P_x > P_y$$

$$\text{KE per m}^3 \text{ of water} = \frac{1}{2} \rho v^2$$

$$\text{KE}_x = \frac{1}{2} \rho v_x^2$$

$$\text{KE}_y = \frac{1}{2} \rho v_y^2$$

$$\text{KE}_x < \text{KE}_y$$

Previous Years' Questions

Sol 1: (C) $W_{\text{app}} = W_{\text{actual}} - \text{Upthrust}$

$$\text{Upthrust } F = V_s \rho_L g$$

Here, V_s = volume of solid,

ρ_L = density of liquid.

At higher temperature $F' = V'_s \rho'_L g$

$$\therefore \frac{F'}{F} = \frac{V'_s}{V_s} \cdot \frac{\rho'_L}{\rho_L} = \frac{(1 + \gamma_s \Delta\theta)}{(1 + \gamma_L \Delta\theta)}$$

Since $\gamma_s < \gamma_L$ (given)

$$\therefore F' < F \text{ or } W'_{\text{app}} > W_{\text{app}}$$

Sol 2: (A) Net force on the free surface of the liquid in equilibrium (from accelerate frame) should be perpendicular to it.

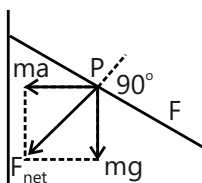

Force on a water particle P on the free surfaces have been shown in the figure. In the figure ma is the pseudo force.

Sol 3: (A) In a freely falling system $g_{\text{eff}} = 0$ and since,

$$\text{Upthrust} = V_1 \rho_L g_{\text{eff}}$$

(V_1 = immersed volume, ρ_L = density of liquid)

$$\text{Upthrust} = 0.$$

Sol 4: (B)

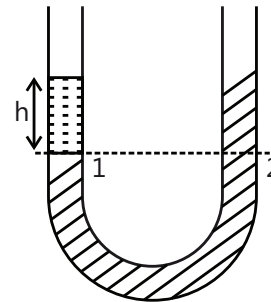

$$p_1 = p_2 \Rightarrow p_0 + \rho_0 gh = p_0 + \rho_{II} gh$$

$$\therefore \rho_1 = \rho_{II}$$

Sol 5: (A)

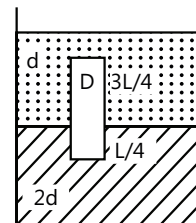

Considering vertical equilibrium of cylinder

Weight of cylinder = Upthrust due to upper

liquid + upthrust due

to lower liquid.

$$\therefore (A/5) (L) D g = (A/5) (3L/4) (d)g$$

$$+ (A/5)(L/4)(2d)(g)$$

$$\therefore D = \left(\frac{3}{4}\right) d + \left(\frac{1}{4}\right) (2d)$$

$$D = \frac{5}{4} d$$

Sol 6: (C) From conservation of energy

$$v_2^2 = v_1^2 + 2gh \quad \dots(i)$$

[can also be found by applying Bernoulli's theorem]

From continuity equation

$$A_1 v_1 = A_2 v_2$$

$$v_2 = \left(\frac{A_1}{A_2} \right) v_1 \quad \dots(ii)$$

Substituting value of v_2 from Eq. (ii) in Eq. (i)

$$\frac{A_1^2}{A_2^2} v_1^2 = v_1^2 + 2gh$$

$$\text{or } A_2^2 = \frac{A_1^2 v_1^2}{v_1^2 + 2gh}$$

$$\therefore A_2 = \frac{A_1 v_1}{\sqrt{v_1^2 + 2gh}}$$

Substituting the given value

$$A_2 = \frac{(10^{-4})(1.0)}{\sqrt{(1.0)^2 + 2(10)(0.15)}}$$

$$A_2 = 5.0 \times 10^{-5} \text{ m}^2$$

Sol 7: (A) Velocity of efflux at a depth h is given by $v = \sqrt{2gh}$. Volume of water flowing out per second from both the holes are equal.

$$\therefore a_1 v_1 = a_2 v_2$$

$$\text{or } (L^2) \sqrt{2g(y)} = \pi R^2 \sqrt{2g(4y)}$$

$$\text{or } R = \frac{L}{\sqrt{2\pi}}$$

Sol 8: (D) l will decrease because the block moves up and h will decrease because the coin will displace the volume of water (V_1) equal to its own volume when it is in the water whereas when it is on the block it will displace the volume of water (V_2) whose weight is equal to weight of coin and since density of coin is greater than the density of water, $V_1 < V_2$.

Sol 9: (A) Applying continuity equation at 1 and 2, we have

$$A_1 v_1 = A_2 v_2 \quad \dots(i)$$

Further applying Bernoulli's equation at these two points, we have

$$p_0 + \rho gh + \frac{1}{2} \rho v_1^2 = p_0 + 0 + \frac{1}{2} \rho v_2^2 \quad \dots(ii)$$

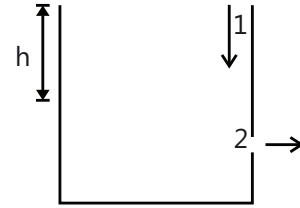

Solving eq. (i) and (ii), we have

$$v_2^2 = \frac{2gh}{1 - \frac{A_2^2}{A_1^2}}$$

Substituting the values, we have

$$v_2^2 = \frac{2 \times 10 \times 2.475}{1 - (0.1)^2} = 50 \text{ m}^2 / \text{s}^2$$

Sol 10: (B) $\Delta p_1 = \frac{4T}{r_1}$ and $\Delta p_2 = \frac{4T}{r_2}$

$$r_1 < r_2$$

$$\therefore \Delta p_1 > \Delta p_2$$

\therefore Air will flow from 1 to 2 and volumes of bubble at end 1 will decrease.

Therefore, correct option is (B).

Sol 11: (B) When cylinder is displaced by an amount x from its mean position, spring force and upthrust both will increase. Hence, Net restoring force = extra spring force + extra upthrust

$$\text{or } F = -(kx + Ax \rho g) \text{ or } a = - \left(\frac{k + \rho Ag}{M} \right) x$$

$$\text{Now, } f = \frac{1}{2\pi} \sqrt{\frac{a}{|x|}} = \frac{1}{2\pi} \sqrt{\frac{k + \rho Ag}{M}}$$

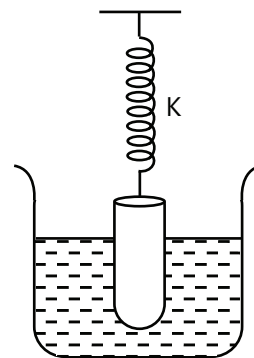

Sol 12: (D) The force of surface tension acting on the slider balances the force due to the weight.

$$\Rightarrow F = 2T \ell = w$$

$$\Rightarrow 2T(0.3) = 1.5 \times 10^{-2}$$

$$\Rightarrow T = 2.5 \times 10^{-2} \text{ N/m}$$

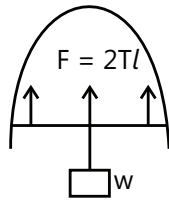

$$r^2 = \frac{2 R^4 \rho_w g}{3 T}$$

$$r = R^2 \sqrt{\frac{2 \rho_w g}{3 T}}$$

Sol 13: (B)

At equilibrium $\Sigma F = 0$

$$kx_0 + \left(\frac{AL}{2} \sigma g\right) - Mg = 0$$

$$x_0 = Mg \left[1 - \frac{LA\sigma}{2M}\right]$$

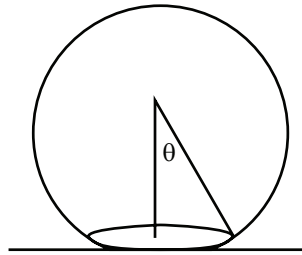
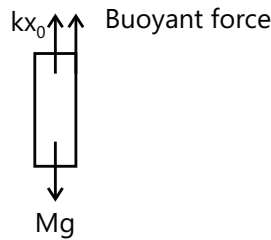

JEE Advanced/Boards

Exercise 1

Sol 14: (C)

$$\rho 4 \pi R^2 \Delta R L = T 4 \pi [R^2 - (R - \Delta R)^2]$$

$$\rho R^2 \Delta R L = T [R^2 - R^2 + 2R \Delta R - \Delta R^2]$$

$$\rho R^2 \Delta R L = T 2R \Delta R \quad (\Delta R \text{ is very small})$$

$$R = \frac{2T}{\rho L}$$

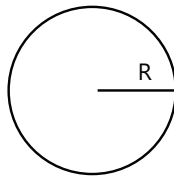

Sol 15: (C)

$$(76)(8) = (54 - x)(76 - x)$$

$$x = 38 \text{ cm}$$

Length of air column = $54 - 38 = 16 \text{ cm}$.

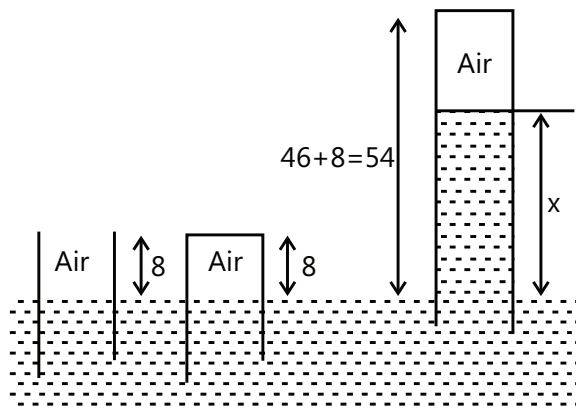

Sol 16: (D)

$$(2\pi r T) \sin \theta = \frac{4}{3} \pi R^3 \rho_w g$$

$$T \times \frac{r}{R} \times 2\pi r = \frac{4}{3} \pi R^3 \rho_w g$$

Sol 1: Pressure at A = $P_0 + \frac{Mg}{A} = P_0 + \rho gh$

$$A = \pi (0.04)^2 - (0.01)^2 = \pi \times 15 \times 10^{-4}$$

$$\frac{M}{A} = \rho h$$

$$h = \frac{M}{A\rho} = \frac{3}{\pi \times 15 \times 10^{-4} \times 1000} = \frac{2}{\pi} \text{ m}$$

mass of water = $750 \text{ gm} = 0.75 \text{ kg}$

mass of water below piston

$$= 0.75 - (1000) (\pi \times (0.01)^2) \times h$$

$$= (1000) \times \pi \times (0.04)^2 \times H$$

$$0.75 = \frac{\pi}{10} \times \frac{2}{\pi} + \frac{16\pi}{10} \times H$$

$$0.55 = \frac{16\pi}{10} H \Rightarrow H = \frac{5.5}{16\pi} = \frac{11}{32\pi} \text{ m}$$

Sol 2: Net force on the ball in water

$$F_B = \rho_w Vg - \frac{\rho_w Vg}{2} = \frac{\rho_w Vg}{2} = mg$$

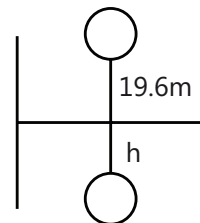

Let us assume that ball will go up to depth h in water. By work energy theorem

$$-mg(19.6) + mgh = 0 \Rightarrow h = 19.6 \text{ m}$$

Upward force $F = mg$ in water

Acceleration = g

Time required to come on surface

$$= \sqrt{\frac{2s}{g}} = \sqrt{\frac{2 \times 19.6}{9.8}} = 2 \text{ sec}$$

Time required to go inside surface is also 2 sec

So total time required = 4 sec

Sol 3:

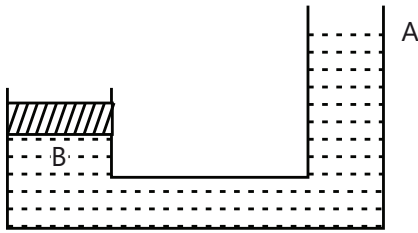

Pressure at point A = $P_0 + \frac{F}{A_1} = P_A$

Pressure at point B = $P_0 + \frac{mg}{A_2} = P_B$

Difference in pressure = $\rho g \times 8 = P_B - P_A$

$$\Rightarrow P_0 + \frac{F}{A_1} - P_0 - \frac{mg}{A_2} = -\rho g \times 8$$

$$\frac{F}{A_1} = \frac{6000}{800 \times 10^{-4}} - 750 \times 10 \times 8 = \frac{15}{2} \times 10^4 - 6 \times 10^4$$

$$\frac{F}{A_1} = \frac{3}{2} \times 10^4$$

$$F = 1.5 \times 10^4 \times 25 \times 10^{-4}$$

$$F = 37.5 \text{ N}$$

Sol 4:

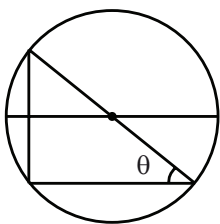

(a) $\tan \theta = \frac{a}{g} = 1$

$$\theta = 45^\circ$$

Maximum gauge pressure = $\rho \sqrt{a^2 + g^2} r$

$$= 800 \times 10 \sqrt{2} \times 1.2 = 9600 \sqrt{2} \text{ N/m}^2$$

(b) h = depth of lake

When bubble is at bottom pressure inside

$$= P_0 + \rho gh$$

When bubble is at surface pressure is = P_0

T_0 = surface tension

$$P_0 = \frac{2T}{r} = \frac{T}{r}$$

$$P_0 + \rho gh = \frac{2T}{r}$$

$$\frac{T}{r} + \rho gh = \frac{2T}{r}$$

$$\rho gh = \frac{T}{r} = P_0 = \rho_m g h_m$$

$$\rho_m = n\rho$$

$$h = nH$$

Sol 5: Upward force on test tube initially = $\rho_s A \times 0.1 g$

Upward force after adding liquid = $\rho_w A \times 0.4g$

Weight of the fluid = $\rho_w A \times 0.4g - \rho_w A \times 0.1g = \rho' A \times 0.4 g$

$$\Rightarrow \rho' = \frac{3\rho_w}{4}$$

Sol 6: At point A by Bernoulli equation

$$P_0 + \sigma g \frac{h}{4} = \frac{1}{2} \sigma v^2 + P_0 \Rightarrow v = \sqrt{\frac{gh}{2}}$$

$$\text{Time take} = \frac{\sqrt{2(3h/4)}}{g} = \sqrt{\frac{3h}{2g}}$$

Distance travelled = vt

$$= \sqrt{\frac{gh}{2}} \times \sqrt{\frac{3h}{2g}}$$

$$\text{Distance} = \frac{h}{2} \sqrt{3}$$

At point B

$$P_0 = \sigma g \frac{h}{2} = P_0 + (+2\sigma g (-h/4)) + \frac{1}{2} 2\sigma v'^2$$

$$\frac{gh}{2} = -\frac{gh}{2} + v'^2$$

$$v' = \sqrt{gh}$$

$$\text{Time } t' = \sqrt{\frac{2(h/4)}{g}} = \sqrt{\frac{h}{2g}}$$

$$\text{Distance travelled} = vt' = \sqrt{gh} \sqrt{\frac{h}{2g}} = \frac{h}{\sqrt{2}}$$

$$\text{Ratio of distance travelled} = \frac{h\sqrt{3}}{2 \frac{h}{\sqrt{2}}} = \frac{\sqrt{3}}{\sqrt{2}}$$

Sol 7: Force exerted is change in momentum per sec

$$= \frac{d(mv)}{dt} = v \frac{dm}{dt}$$

$$= v \rho Av$$

$$= \rho Av^2 = 1000 \times 2 \times 10^{-4} \times 100$$

$$= 20 \text{ N}$$

Sol 8: By Bernoulli's equation

$$P_0 + \rho gh + \frac{1}{2} \rho v_1^2 = P_0 + \frac{1}{2} \rho v_2^2$$

By continuity equation

$$A_1 v_1 = A_2 v_2$$

$$v_1 = \frac{v_2}{2}$$

$$gh + \frac{1}{2} \left(\frac{v_2}{2} \right)^2 = \frac{1}{2} v_2^2$$

$$gh = \frac{v_2^2}{2} [1 - 1/4] = 3/8 v_2^2$$

$$v_2 = \sqrt{\frac{8gh}{3}} \Rightarrow v_1 = \sqrt{\frac{2gh}{3}} = \sqrt{\frac{2}{3}}$$

$$\text{Volume flow rate} = \sqrt{\frac{2}{3}} \times 10^{-4} \text{ m}^3/\text{s}$$

$$= 60 \sqrt{\frac{2}{3}} \times 10^{-4} \text{ m}^3/\text{min}$$

$$= 60 \sqrt{\frac{2}{3}} \times \frac{1}{10} \text{ litre/min}$$

$$= 4.9 \text{ litre/min}$$

Sol 9:

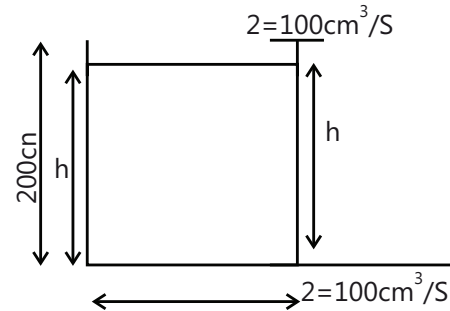

By Bernoulli's equation

$$P_0 + \rho gh = P_0 + \frac{1}{2} \rho v^2$$

$$v = \sqrt{2gh}$$

$$Q = 100 \text{ cm}^3/\text{s}$$

$$A = 1 \text{ cm}^2$$

$$v = 100 \text{ cm/s} = 1 \text{ m/s}$$

$$v = \sqrt{2 \times 10 \times h} = 1$$

$$h = \frac{1}{20} \text{ m} = 5 \text{ cm}$$

Sol 10:

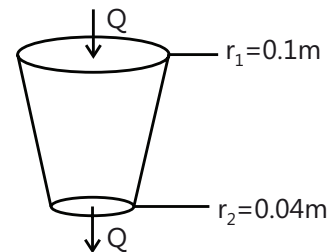

By Bernoulli's equation

$$P_1 + \frac{1}{2} \rho v_1^2 = P_2 + \frac{1}{2} \rho v_2^2$$

$$-P_2 + P_1 = 10 \text{ N/m}^2$$

$$10 + \frac{1}{2} \times 1250 v_1^2 = \frac{1}{2} \times 1250 v_2^2 \quad \dots(i)$$

Continuity equation

$$A_1 v_1 = A_2 v_2$$

$$\pi (0.1)^2 v_1 = \pi (0.04)^2 v_2$$

$$\frac{1}{100} v_1 = \frac{4 \times 4}{10000} v_2$$

$$v_1 = 0.16 v_2 \quad \dots(ii)$$

By (i) and (ii)

$$10 + 625 (0.16 v_2)^2 = 625 (v_2)^2$$

$$625 (0.9744) v_2^2 = 10$$

$$v_2 = 0.128 \text{ m/s}$$

$$Q = A_2 v_2$$

$$= \pi (0.04)^2 \times 0.128$$

$$= \pi \times 16 \times 10^{-4} \times 0.128$$

$$= 6.44 \times 10^{-4} \text{ m}^3/\text{s}$$

Sol 11: Since velocity is greater than terminal velocity, so it will decrease until velocity reaches terminal velocity

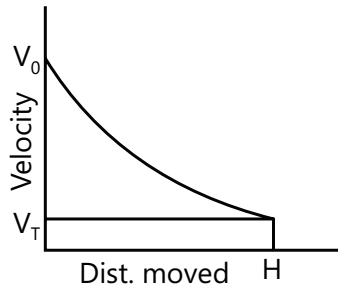

Sol 12: Terminal velocity = $V = \frac{2}{9} r^2 \frac{(\rho - \sigma)}{\eta} g$

$$= \frac{2}{9} 10^{-8} \frac{(10^4 - 10^3) \times 9.8}{9.8 \times 10^{-6}}$$

$v = 20 \text{ m/s}$

Distance required to reach terminal velocity is

$$h = \frac{v^2}{2g} = \frac{(20)^2}{2 \times 10} = \frac{400}{20} = 20 \text{ m}$$

Sol 13:

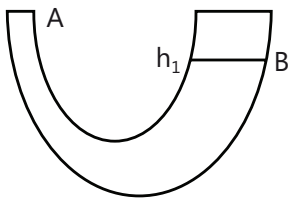

$$P_A = P_0 - \frac{2T}{r_1}$$

$$P_B = P_0 - \frac{2T}{r_2}$$

$$P_B - P_A = \rho gh = 2T \left[\frac{1}{r_1} - \frac{1}{r_2} \right] = 2T [2000 - 200]$$

$$\rho gh = 2 \times 2 \times 7 \times 9 = 252$$

$$h = \frac{252}{10 \times 10^3} = 2.5 \text{ cm}$$

Sol 14: Surface energy of bubble = $4\pi r^2 T_1$

Surface energy of drop = $4\pi r_2^2 T_2$

Volume of bubble and drop is same so

$$4\pi R^2 d = (4/3) \pi r_2^3$$

$$r_2^3 = 3R^2 d$$

$$r_2^2 = (3R^2 d)^{2/3}$$

$$\frac{P_1}{P_2} = \frac{4T}{R2T} \quad r_2 = \frac{2r_2}{R} = \sqrt[3]{\frac{24d}{R}}$$

$$\frac{P_2}{P_1} = \sqrt[3]{\frac{R}{24d}}$$

Sol 15: $P_0 + \frac{4T}{r_1} + \frac{4T}{r} = P_0 + \frac{4T}{r_2}$

$$\Rightarrow r = \frac{r_1 r_2}{r_1 - r_2}$$

Sol 16: Let the volume of bearer be V

Then balancing force on beaker

$$\rho_w V g = (0.39)g + \rho_w \times 250 g$$

$$10^3 \times V = 0.39 + 0.25$$

$$V = 640 \times 10^{-6} \text{ m}^3$$

$$V = 60 \text{ cm}^3$$

Volume of glass = $640 - 500 = 140 \text{ cm}^3$

$$\text{Density} = \frac{m}{v} = \frac{390}{140} = 2.785 \text{ gm/cc}$$

Sol 17: Plug will open when float is lifted upwards due to buoyant force



Balancing force we get

$$\rho h' \times \pi (0.1)^2 \times g = 3g$$

$$h' = \frac{3}{1000 \times \pi \times \frac{1}{100}} = \frac{3}{10\pi}$$

$$\text{height } h = h' + 10 \text{ cm} = \frac{3}{10\pi} + \frac{1}{10} = \frac{3 + \pi}{10\pi}$$

Sol 18:

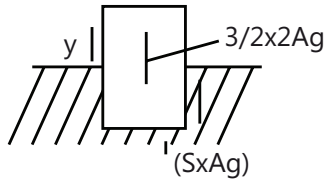

(a) By Newton's second law

a = Upward acceleration

$$\frac{-\rho}{2} \times 2 Ag + \rho(1 - y) Ag = (\rho/2) 2Aa$$

$$-\rho Ag + \rho(1-y) Ag = \rho Aa$$

$$-g + g - gy = a$$

$$a = -gy$$

acceleration is density proportional to the displacement so it will perform SHM

$$a = -\omega^2 y$$

$$\omega^2 = g$$

$$\omega = \sqrt{g} = \sqrt{\pi^2} = \pi$$

$$\text{Time period} = \frac{2\pi}{\omega} = 2 \text{ sec}$$

(b) Time taken for rod to go from 1 extreme position to other is half of the time period

So time taken = 2/2 = 1 sec

Sol 19:

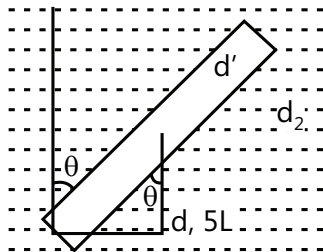

$$\text{Torque on rod} = (d_1 \ell Sg - d_2 \ell sg) l/2 \sin \theta$$

for small θ

$$\tau = (d - d_2) (\ell^2/2) s g \theta$$

$$\text{Net torque} = I\alpha$$

$$I\alpha = (d_1 - d_2) \ell^2 s g \theta$$

$$I = \frac{(d_1 s \ell)^2}{3}$$

$$\frac{d_1 s \ell^3}{3} \alpha = (d_1 - d_2) \frac{\ell^2}{2} \rho g \theta$$

$$\frac{d_1 \ell \alpha}{3} = \frac{(d_1 - d_2)}{2} g \theta$$

$$\alpha = \frac{3(d_1 - d_2)g}{2d_1 \ell} \theta$$

$$\omega = \sqrt{\frac{3(d_1 - d_2)g}{2d_1 \ell}}$$

Sol 20:

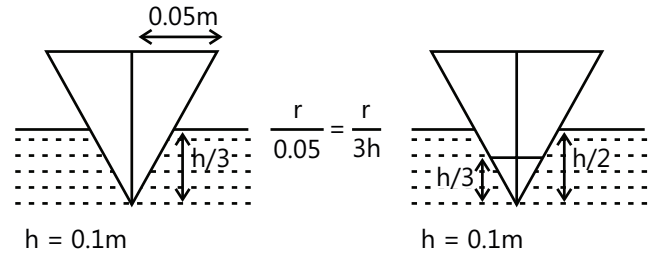

$$h = 0.1m$$

By force balance

$$mg = 0.8 \left(\frac{1}{3} \pi \left(\frac{0.05}{3} \right)^2 \left(\frac{h}{3} \right) \right) \quad \dots(i)$$

When liquid is added

$$Mg + \rho \left(\frac{1}{3} \pi \left(\frac{0.05}{3} \right)^2 \left(\frac{h}{3} \right) \right) = 0.8 \left(\frac{1}{3} \pi \left(\frac{0.05}{2} \right)^2 \left(\frac{h}{2} \right) \right) \quad \dots(ii)$$

By (i) and (ii)

$$(0.8) \left(\frac{1}{3} \pi \frac{(0.05)^2 h}{3^3} \right) + \rho \left(\frac{1}{3} \pi \frac{(0.05)^2 h}{3^3} \right) = 0.8 \left(\frac{1}{3} \pi \frac{(0.05)^2 h}{2^3} \right)$$

$$\frac{0.8 + \rho}{3^3} = \frac{0.8}{8} = 0.1 \Rightarrow 0.8 + \rho = 2.7$$

$$\rho = 1.9$$

Sol 21:

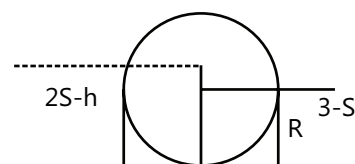

Balancing force on both sides

Horizontal force acting on the cylinder can be assumed to be acting on the cross-sectional area in the vertical direction

$$2\rho gh \cdot \frac{h}{2} = \frac{3\rho g R.R}{2}$$

$$h^2 = \frac{3}{2} R^2$$

$$h = \sqrt{\frac{3}{2}} R$$

Sol 22:

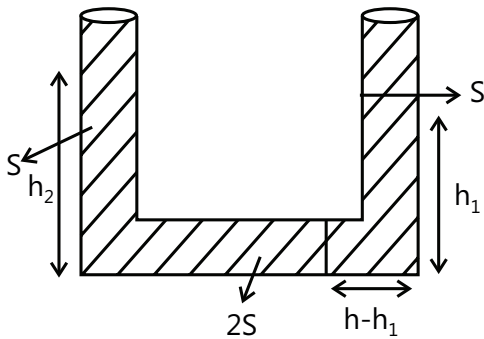

$$h = h_2 - (h - h_1)$$

$$h = h_2 - h + h_1$$

$$h = \frac{h_1 + h_2}{2}$$

$$P_0 + \rho gh_1 + \rho a (h - h_1) + 2\rho a (h + h_1) - 2\rho g (h - h_1) - \rho gh = P_0$$

$$gh_1 + ah - ah_1 + 2ah + 2ah_1 - 2gh + 2gh_1 - gh = 0$$

$$h_1 (g - a + 2a + 2g) + h (a + 2a - 2g - g) = 0$$

$$h_1 = \frac{3(g - a)h}{3g + a}$$

$$a = g/2$$

$$\Rightarrow h_1 = \frac{\frac{3h}{2}}{3 + \frac{1}{2}} = \frac{3h}{7}$$

$$h_2 = h + h - h_1$$

$$h_2 = 2h - h_1$$

$$\text{Difference in height} = h_2 - h_1$$

$$= 2h - h_1 - h_1 = 2(h - h_1) = \frac{8h}{7}$$

Sol 23:

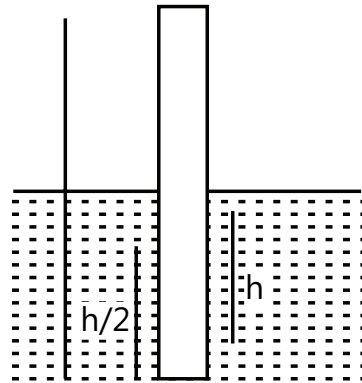

For the rod to be in equilibrium centre of mass of (rod + mass m) system should be below centre of gravity of the volume displaced by the rod.

For minimum m should coincide so.

Suppose h length of rod is below water then, by force balance

$$\sigma(\pi R^2 h) g - \rho \pi R^2 g - mg = 0$$

$$(\pi R^2) (\sigma h - \rho \ell) = m \quad \dots(i)$$

Reaction of centre of mass should be at h/2 distance from bottom

$$\Rightarrow h/2 = \frac{\frac{\rho \ell \pi R^2 \times \ell}{2}}{m + \rho \ell \pi R^2} \quad \dots(ii)$$

$$\Rightarrow h^2 = \frac{\rho \ell^2}{\sigma} \Rightarrow h = \ell \sqrt{\frac{\rho}{6}} \quad \dots (iii)$$

By (i) and (iii)

$$m = (\sqrt{\sigma \ell} - \rho) \pi R^2 \ell$$

Sol 24: Volume of water collected = A.V

A = cross sectional area perpendicular to the rain.

v = velocity of rain

in 1st beaker $A_2 = A_1 \cos 30^\circ$

in 2nd beaker $A'_3 = A \cos 60^\circ$

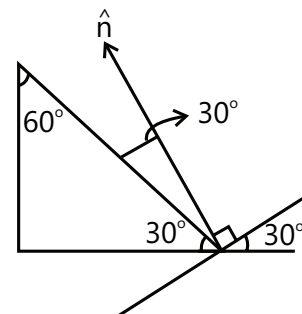

$$A_1 = \frac{A}{\cos 30^\circ}$$

$$\Rightarrow A_2 = \frac{A}{\cos 30^\circ} \cos 30^\circ = A$$

$$\Rightarrow A_3 = \frac{A}{2}$$

$$\text{So } \frac{Q_2}{Q_3} = \frac{A_2 V}{A_3 V} = 2 : 1$$

Sol 25: (a) By Bernoulli's equation

$$P_0 + \rho g(3.6) = P_0 + \frac{1}{2} \rho v^2$$

$$v = \sqrt{2g(3.6)} = \sqrt{72}$$

$$v = 6\sqrt{2} \text{ m/s}$$

(b) Discharge rate = $\pi r^2 v$

$$= \pi \times \frac{16}{\pi} \times 10^{-4} \times 6\sqrt{2} \text{ m}^3/\text{s}$$

$$= 9.6 \sqrt{2} \times 10^{-3} \text{ m}^3/\text{s}$$

(c) By Bernoulli equation

$$P_A + \frac{1}{2} \rho v^2 + \rho g(5.4) = P_0 + \frac{1}{2} \rho V^2$$

$$P_A = P_0 - \rho g \times 5.4$$

$$= 10 \times 10^4 - 5.4 \times 10^4$$

$$= 4.6 \times 10^4 \text{ Pa}$$

Sol 26: Pressure at C = P_c

By Bernoulli's equation

$$P_0 + \rho g h_1 = P_0 + \frac{1}{2} \rho V_D^2$$

$$\frac{1}{2} \rho V_D^2 = \rho g h_1$$

$$P_0 + \rho g h_1 = P_c + \frac{1}{2} \rho V_C^2$$

$$A_C V_C = A_D V_D$$

$$A_C = \frac{A_D}{2}$$

$$\Rightarrow v_C = 2v_D$$

$$P_0 + \rho g h_1 = P_c + 2\rho V_D^2$$

$$\Rightarrow P_c = P_0 + \rho g h_1 - 4\rho g h_1 = P_0 - 3\rho g h_1 \quad \dots(i)$$

Pressure at C can also be written as

$$P_c + \rho g h_2 = P_0$$

$$P_c = P_0 - \rho g h_2 \quad \dots(ii)$$

By (i) and (ii)

$$\rho g h_2 = 3\rho g h_1$$

$$h_2 = 3h_1$$

Sol 27: By force equilibrium on the cube

$$F_{\text{gravity}} + F_{\text{buoyant}} + F_{\text{surface tension}} = 0$$

$$-mg + \rho_w a^2 hg - S \times 4a = 0$$

$$h = \frac{mg + 4Sa}{\rho_w a^2 g}$$

Exercise 2

Sol 1: (B) By Newton's second law

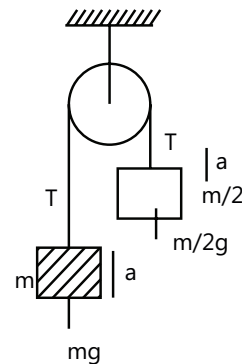

$$T - \frac{mg}{2} = \frac{ma}{2}$$

$$T = \frac{m}{2} (g + a) \quad \dots (i)$$

$$-T + mg = ma \quad \dots (ii)$$

By (i) and (ii)

$$\frac{-m}{2} (g + a) + mg = ma$$

$$\frac{-g}{2} - \frac{a}{2} + g = a$$

$$\frac{g}{2} = \frac{3a}{2}; a = \frac{g}{3}$$

Effective acceleration of the bucket is $\left(g - \frac{g}{3}\right)$

downwards water pressure at the bottom above atmospheric pressure is

$$P = \frac{2g}{3} h \rho = 1000 \times \frac{2}{3} \times 10 \times \frac{15}{100} = 1 \text{ kPa}$$

Sol 2: (D) Buoyant force = sum of all forces acting on the body

= force acting on the slant surface

+ force acting on the bottom surface

$$F_B = F_s + F_b$$

$$F_B = (1/3) \pi R^2 H \rho g$$

$$F_b = \pi R^2 \rho g H$$

$$\Rightarrow F_s = (-2/3) \pi R^2 \rho g H$$

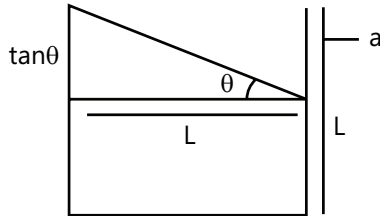
Sol 3: (B)

A = area of the base

$$\tan \theta = a/g$$

Finally 1/3 rd of the water spilled out

So volume of water spilled out finally

$$= V_f = \frac{2 \tan \theta \times A}{2} = \frac{L^3 \tan \theta}{2}$$

this is 1/3 volume of L^3

$$\Rightarrow \frac{\tan \theta}{2} = \frac{1}{3} \Rightarrow \tan \theta = 2/3 = a/g$$

$$a = 2g/3$$

Sol 4: (D) Force applied by the liquid will be same on both the vessels as the mass of liquid is same in both the vessels

Sol 5: (A) Total force exerted on the base by water and cane's slant surface = mg

$$= 1/3 \pi R^2 H \rho g \text{ downwards}$$

Force exerted by the water =

$$(\rho g H) (\pi R^2) \text{ downwards}$$

So force exerted by the slant surface =

$$2/3 \rho g H \pi R^2 \text{ upwards}$$

So force exerted by water on slant surface = $2/3 \rho g H \pi R^2$

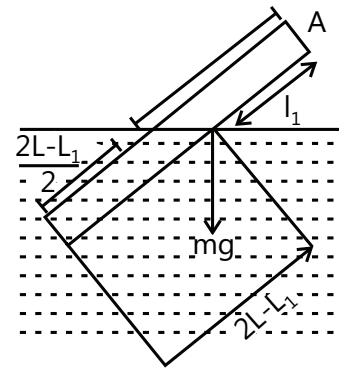
Sol 6: (A)

Let the length of rod that extends out of water is λ_1 , since the rod is in equilibrium

So balancing net torque about point A

$$\begin{aligned} \text{we get } (\rho A(2L-L_1)g) \left(\frac{2L+L_1}{2} \right) \cos \theta \\ = 0.75 \rho A L g L \cos \theta \end{aligned}$$

$$\frac{4L^2 - L_1^2}{2} = \frac{3}{4} L^2$$

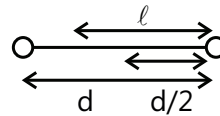
Sol 7: (B)

By force equilibrium we get

$$-Mg - 2Mg - mg + \frac{\rho V g}{2} + \frac{\rho V g}{2} = 0$$

$$\Rightarrow m = \rho v - 3M$$

....(i)

By torque equilibrium about mass M we get

$$-mg(d - \ell) - 2Mgd + \frac{d\rho V g}{2} = 0$$

$$m\ell - d(m + 2M - \frac{\rho V}{2}) = 0$$

$$\ell = \frac{d \left(2M + m - \frac{\rho V}{2} \right)}{m}$$

... (ii)

By (i) and (ii) we get $\ell = \frac{d(\rho V - 2M)}{2(\rho V - 3M)}$

Sol 8: (B) By work energy theorem

$$W_{\text{water}} + W_{\text{gravity}} = \Delta KE = 0$$

$$(\sigma v g h) - \rho v g (h + H) = 0$$

$$\sigma h = \rho (h + H)$$

$$H = \frac{(\sigma - \rho)h}{\rho} = \left(\frac{\sigma}{\rho} - 1 \right) h$$

Sol 9: (A) Buoyant force = $\rho_w \times \frac{4}{3} \pi R^3 g$
 Gravitational force = $(\sigma \rho_w) (\frac{4}{3} \pi (R^3 - r^3)) g$
 Sphere is in equilibrium so

$$\rho_w \frac{4}{3} \pi R^3 g = (\sigma \rho_w) (\frac{4}{3} \pi (R^3 - r^3)) g$$

$$R^3 = \sigma (R^3 - r^3)$$

$$\frac{1}{\sigma} = 1 - \frac{r^3}{R^3}$$

$$\frac{r^3}{R^3} = 1 - \frac{1}{\sigma} = \frac{\sigma - 1}{\sigma}$$

$$\frac{R}{r} = \left(\frac{\sigma}{\sigma - 1} \right)^{1/3}$$

Sol 10: (D) Force exerted = change in momentum per sec

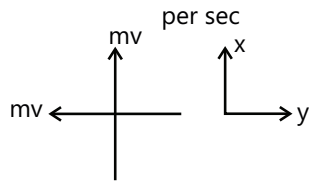

$$= \frac{mv\hat{j} - mv\hat{i}}{t} = \rho L v \hat{j} - \rho L v \hat{i} = \sqrt{2} \rho v L$$

Sol 11: (A) Force exerted by water = $\rho A V^2$

A = area of hole

V = velocity of water through hole

Friction force = μMg

for the vessel to just move

$$\rho A V^2 = \mu Mg$$

$$\rho \times \frac{\pi D^2}{4} \times 2 g H = \mu Mg \Rightarrow D = \sqrt{\frac{2\mu M}{\pi \rho H}}$$

Sol 12: (C) We know that force applied is proportional to velocity of shaft. So if the force is increased three times, velocity will also increase three times.

Sol 13: (A) Viscous force $F = -\eta A \frac{dv}{dx}$

$$F = -\eta A \frac{v}{t}$$

$$F = mg \sin 37^\circ = \frac{3mg}{5}$$

$$\eta = \frac{3mgt}{5AV} = \frac{3\rho a^3 gt}{5a^2 V} = \frac{3\rho a g t}{5V}$$

Sol 14: (C) Graph (c) best represents the motion of raindrop because velocity of rain approaches the terminal velocity.

Sol 15: (C) Graph (D) incorrect because at $t = 0$; $x = 0$ and graph will not be straight time

Sol 16: (C)

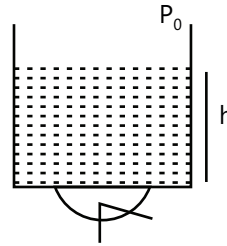

$$P = P_0 + \frac{2T}{r}$$

$$P_0 + \frac{2T}{r} - \rho gh = P_0$$

$$\frac{2T}{r} = \rho gh$$

$$h = \frac{2T}{r\rho g} = \frac{2 \times 75 \times 10^{-3}}{\frac{10^{-4}}{2} \times 1000 \times 10} = 0.30 \text{ m}$$

$$h = 30 \text{ cm}$$

Sol 17: (B)

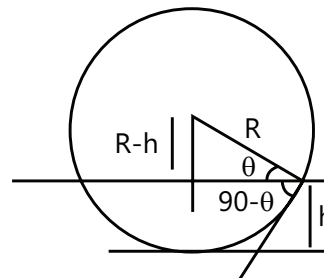

$$\cos(90 - \theta) = \sin \theta = \frac{R-h}{R}$$

$$\text{Angle of contact} = 90 - \theta = \cos^{-1} \left(\frac{R-h}{R} \right)$$

Sol 18: (D) Force exerted by liquid = $\rho g (2h) \cdot A = F$
 weight of liquid is W

Force exerted by liquid on walls = $F - W$
 (upwards)

So force exerted by the walls on the liquid
 = $(F - W)$ downwards

Multiple Correct Choice Type

Sol 19: (C, D)

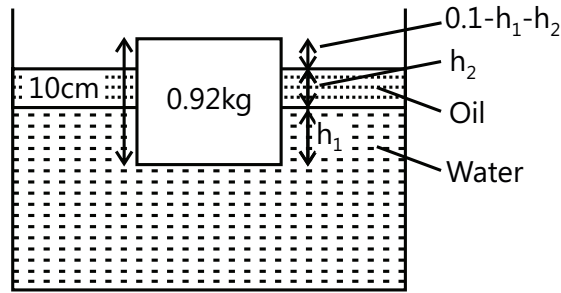

Balancing net force on the block we get

$$-0.92 \times 10 + (1000) \times h_1 \times (0.01) \times 10 + (600)h_2 \times (0.01) \times 10 = 0$$

$$10 h_1 + 6h_2 = 0.92$$

if $h_2 = 4 \text{ cm}$

then $10h_1 + 6 \times 0.04 = 0.92$

$$10h_1 = 0.68$$

$$h_1 = \frac{0.68}{10} = 0.068 \text{ m} = 6.8 \text{ cm}$$

$h_1 + h_2$ should be less than 10 cm so

$$h_2 < 4 \text{ cm}$$

and $h_1 + h_2 = 10 \text{ cm}$

$$\Rightarrow 10 h_1 + 6 (0.1 - h_1) = 0.92$$

$$4h_1 + 0.6 = 0.92$$

$$4h_1 = 0.32$$

$$h_1 = 0.08 \text{ m}$$

$$\Rightarrow h_1 = 8 \text{ cm}$$

$$h_2 = 2 \text{ cm}$$

Sol 20: (B, D) Thrust exerted by the water is ρAV^2 if velocity is doubled then thrust will increase 4 times.

$$\text{Energy lost per second} = \frac{1}{2} \frac{dm}{dt} v^2$$

$$= \frac{1}{2} \rho Av. v^2 = \frac{1}{2} \rho Av^3$$

If velocity is doubled then energy lost per second will be 8 times

Sol 21: (A, C)

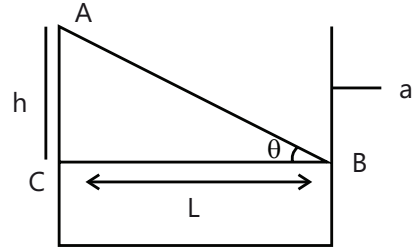

$$P_A = P_0$$

$$P_B = P_0$$

$$P_B = P_A + \rho gh - \rho a l = P_0$$

$$gh = a l$$

$$\tan \theta = \frac{h}{L} = \frac{a}{g}$$

Sol 22: (B, C)

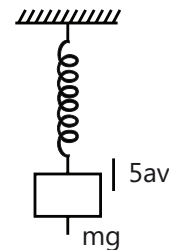

Balance A will read less than 2 kg as an upward buoyant force is acting on the block. Balance B will read more than 5 kg as downward reaction of the block due to buoyant force is acting on beaker.

Sol 23: (A, D)

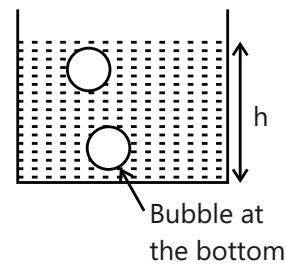

Pressure inside the bubble at the bottom is

$$P_1 = P_0 + \rho gh + \frac{2T}{r_1}$$

Pressure inside the bubble near the surface is

$$P_2 = P_0 + \frac{2T}{r_2}$$

Pressure inside the bubble near the surface is

$$P_2 = P_0 + \frac{2T}{r_2}$$

So pressure will decrease as we move upwards.

Sol 24: (A, C)

Velocity of fluid coming out of the hole =

$$v = \sqrt{2gy}$$

time taken by the fluid to collide with surface =

$$t = \sqrt{\frac{2(h+h-y)}{g}}$$

range = vt

$$= \sqrt{2gy} \cdot \sqrt{\frac{2(h+h-y)}{g}}$$

$$R = \sqrt{4y(2h-y)} \quad \text{For maximum } R, \frac{dR}{dy} = 0$$

$$\Rightarrow \frac{1}{\sqrt{4y(2h-y)}} (2h - 2y) = 0$$

$$\Rightarrow y = h$$

$$R_{\max} = \sqrt{4h^2} = 2h$$

Assertion Reasoning Type

Sol 25: (B) Pressure of air decreases with increase in height so when pressure outside the balloon is equal to balloon pressure, it will not size up.

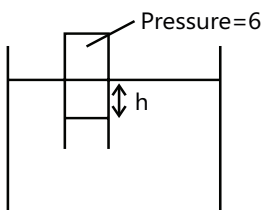
Sol 26: (D)

Pressure inside the tube is $P = P_0 + \rho gh$

When pressure changes height will also change.

So Statement-I is true.

Buoyant force is independent of atmospheric pressure.

Sol 27: (A) Suppose submarine is resting on the floor, then water is exerting only net downward force on the submarine as lower surface is not available for the upward force.

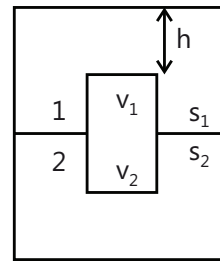
Sol 28: (D)

Force exerted by liquid - 1 = $(\rho gH + P_0) A$ downwards

So statement-I is false

Sol 29: (D) Coefficient of viscosity of gases increase with increasing temperature

Sol 30: (A) Free surface is always perpendicular to the g_{eff} . Liquids at rest can have only normal forces.

Previous Years' Questions

Sol 1: (D) $F_2 - F_1 = \text{upthrust}$

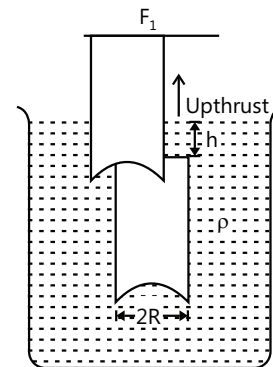

$$\therefore F_2 = F_1 + \text{upthrust}$$

$$F_2 = (\rho_0 + \rho gh) \pi R^2 + V \rho g$$

$$= \rho_0 \pi R^2 + \rho g (\pi R^2 h + V)$$

\therefore Most appropriate option is (D).

$$\text{Sol 2: (A)} \quad k_1 = \left(\frac{\rho_{\text{Fe}}}{\rho_{\text{Hg}}} \right)_{0^\circ\text{C}} \quad \text{and} \quad k_2 = \left(\frac{\rho_{\text{Fe}}}{\rho_{\text{Hg}}} \right)_{60^\circ\text{C}}$$

Here, $\rho = \text{Density}$

$$\therefore \frac{k_1}{k_2} = \frac{(\rho_{\text{Fe}})_{0^\circ\text{C}}}{(\rho_{\text{Hg}})_{0^\circ\text{C}}} \times \left(\frac{\rho_{\text{Hg}}}{\rho_{\text{Fe}}} \right)_{60^\circ\text{C}} = \frac{(1 + 60\gamma_{\text{Fe}})}{(1 + 60\gamma_{\text{Hg}})}$$

Note: In this problem two concepts are used:

(i) When a solid floats in a liquid, then

$$\text{Fraction of volume submerged (k)} = \frac{\rho_{\text{solid}}}{\rho_{\text{liquid}}}$$

This result comes from the fact that

$$\text{Weight} = \text{Upthrust}$$

$$V\rho_{\text{solid}}g = V_{\text{submerged}}\rho_{\text{liquid}}g$$

$$\therefore \frac{V_{\text{submerged}}}{V} = \frac{\rho_{\text{solid}}}{\rho_{\text{liquid}}}$$

$$(ii) \frac{\rho_{\theta^\circ\text{C}}}{\rho_{0^\circ\text{C}}} = \frac{1}{1 + \gamma \cdot \theta}$$

This is because $\rho \propto \frac{1}{\text{Volume}}$ (mass remaining constant)

$$\begin{aligned} \therefore \frac{\rho_{\theta^\circ\text{C}}}{\rho_{0^\circ\text{C}}} &= \frac{V_{0^\circ\text{C}}}{V_{\theta^\circ\text{C}}} = \frac{V_{0^\circ\text{C}}}{V_{0^\circ\text{C}} + \Delta V} \\ &= \frac{V_{0^\circ\text{C}}}{V_{0^\circ\text{C}} + V_{0^\circ\text{C}}\gamma\theta} = \frac{1}{1 + \gamma\theta} \end{aligned}$$

Sol 3: (B) Force from right hand side liquid on left hand side liquid.

(i) Due to surface tension force

$$= 2RT \text{ (towards right)}$$

(ii) Due to liquid pressure force

$$\begin{aligned} &= \int_{x=0}^{x=h} (p_0 + \rho gh)(2R \cdot x) dx \\ &= (2p_0Rh + R\rho gh^2) \text{ (towards left)} \end{aligned}$$

$$\therefore \text{Net force is } [2p_0Rh + R\rho gh^2 - 2RT]$$

Sol 4: (C) Let

A_1 = Area of cross-section of cylinder = $4\pi r^2$

A_2 = Area of base of cylinder in air = πr^2

and A_3 = Area of base of cylinder in water

$$= A_1 - A_2 = 3\pi r^2$$

Drawing free body diagram of cylinder

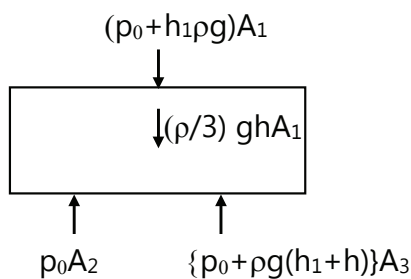

Equating the net downward forces and net upward forces, we get, $h_1 = \frac{5}{3}h$.

Sol 5: (A) Again equating the forces, we get

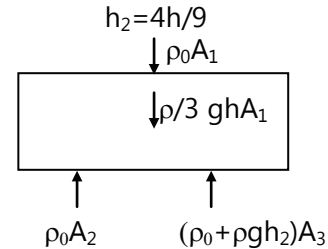

Sol 6: (A) For $h_2 < \frac{4h}{9}$, buoyant force will further decrease. Hence, the cylinder remains at its original position.

Sol 7: (C) Vertical force due to surface tension.

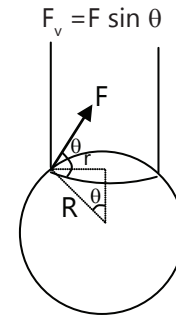

$$\begin{aligned} &= (T2\pi r)(r/R) \\ &= \frac{2\pi r^2 T}{R} \end{aligned}$$

$$\text{Sol 8: (A)} \quad \frac{2\pi r^2 T}{R} = mg = \frac{4}{3}\pi R^3 \cdot \rho \cdot g$$

$$\begin{aligned} \therefore R^4 &= \frac{3r^2 T}{2\rho g} = \frac{3 \times (5 \times 10^{-4})^2 (0.11)}{2 \times 10^3 \times 10} \\ &= 4.125 \times 10^{-12} \text{ m}^4 \end{aligned}$$

$$\begin{aligned} \therefore R &= 1.425 \times 10^{-3} \text{ m} \\ &\approx 1.4 \times 10^{-3} \text{ m} \end{aligned}$$

Sol 9: (B) Surface energy,

$$\begin{aligned} E &= (4\pi R^2)T \\ &= (4\pi) (1.4 \times 10^{-3})^2 (0.11) \\ &= 2.7 \times 10^{-6} \text{ J} \end{aligned}$$

Sol 10: (B, C) Liquid will apply an upthrust on m. An equal force will be exerted (from Newton's third law) on the liquid. Hence, A will read less than 2 kg and B more than 5 kg. Therefore, the correct options are (B) and (C).

Sol 11: (A, B, D)

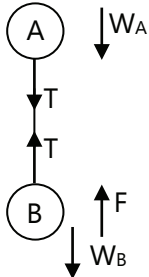

$$F = \text{upthrust} = Vd_f g$$

Equilibrium of A

$$Vd_f g = T + W_A$$

$$= T + Vd_A g \quad \dots(i)$$

Equilibrium of B

$$T + Vd_f g = Vd_B g \quad \dots(ii)$$

Adding eqns. (i) and (ii), we get

$$2d_f = d_A + d_B$$

∴ Option (D) is correct.

From Eq. (i) we can see that

$$d_f > d_A \quad (\text{as } T > 0)$$

∴ Option (A) is correct.

From equation (ii) we can see that,

$$d_B > d_f$$

∴ Option (B) is correct.

∴ Correct options are (A), (B) and (D).

Sol 12: (A)

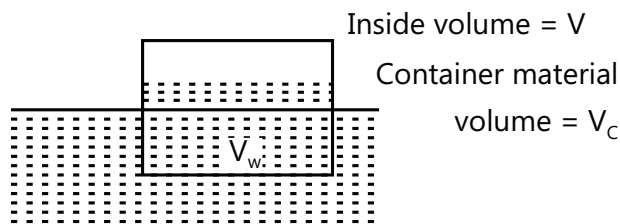

$$m_c g + m_w g = F_B$$

$$\rho_c V_c g + 1V_w g = 1 \left[\frac{V}{2} + \frac{V_c}{2} \right] g$$

$$V_w = \frac{V}{2} + V_c \left[\frac{1}{2} - \rho_c \right]$$

$$\text{If } \rho_c < \frac{1}{2}; V_w > \frac{V}{2}$$

Sol 13: (A, D) At equilibrium,

$$\frac{4}{3} \pi R^3 2\rho g = \frac{4}{3} \pi R^3 \rho g + T$$

$$T = \frac{4}{3} \pi R^3 \rho g$$

$$\therefore \Delta \ell = \frac{4}{3k} \pi R^3 \rho g$$

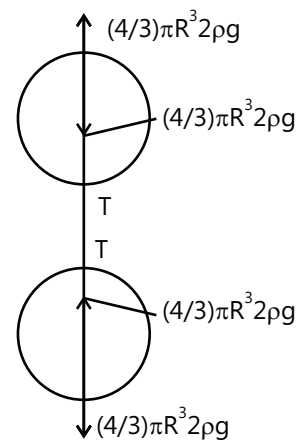

For equilibrium of the complete system, net force of buoyancy must be equal to the total weight of the sphere which holds true in the given problem. So both the spheres are completely submerged.

Sol 14: (C) By $A_1 V_1 = A_2 V_2$

$$\Rightarrow \pi (20)^2 \times 5 = \pi (1)^2 V_2 \Rightarrow V_2 = 2 \text{ m/s}^2$$

Sol 15: (A) $\frac{1}{2} \rho_a V_a^2 = \frac{1}{2} \rho_\ell V_\ell^2$

For given V_a

$$V_\ell \propto \sqrt{\frac{\rho_a}{\rho_\ell}}$$

Sol 16: (C) In P, Q, R no horizontal velocity is imparted to falling water, so d remains same.

In S, since its free fall, $a_{\text{eff}} = 0$

∴ Liquid won't fall with respect to lift.

Sol 17: (A, D) From the given conditions,

$$\rho_1 < \sigma_1 < \sigma_2 < \rho_2$$

$$V_p = \frac{2}{9} \left(\frac{\rho_1 - \sigma_2}{\eta_2} \right) g \quad \text{and} \quad V_Q = \frac{2}{9} \left(\frac{\rho_2 - \sigma_1}{\eta_1} \right) g$$

$$\text{So, } \frac{|\vec{V}_p|}{|\vec{V}_Q|} = \frac{\eta_1}{\eta_2} \quad \text{and} \quad \vec{V}_p \cdot \vec{V}_Q < 0$$

Sol 18: (B, C) $P(r) = K \left(1 - \frac{r^2}{R^2} \right)$

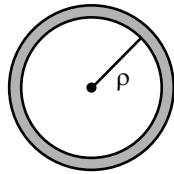

Sol 19: Terminal velocity $v_T = \frac{2}{9} \frac{r^2}{\eta} (\rho - \sigma) g$, where ρ is the density of the solid sphere and σ is the density of the liquid

$$\therefore \frac{v_p}{v_Q} = \frac{(8 - 0.8) \times \left(\frac{1}{2} \right)^2 \times 2}{(8 - 1.6) \times \left(\frac{1}{4} \right)^2 \times 3} = 3$$