

## Solved Examples

### JEE Main/Boards

**Example 1:** A tube closed at one end has a vibrating diaphragm at the other end, which may be assumed to be displacement node. It is found that when the frequency of the diaphragm is 2000 Hz, then a stationary wave pattern is set up in which the distance between adjacent nodes is 8 cm. When the frequency is gradually reduced, then the stationary wave pattern disappears but another stationary wave pattern reappears at a frequency of 1600 Hz. Calculate

- (i) The speed of sound in air,
- (ii) The distance between adjacent nodes at a frequency of 1600 Hz,
- (iii) The distance between the diaphragm and the closed end, and
- (iv) The next lower frequencies at which stationary wave pattern will be obtained.

**Sol:** The standing waves generated inside the tube closed at one end, have the wavelength  $n\lambda = 2L$  where  $L$  is length of the tube. The velocity of the wave in air is given by  $v = f\lambda$ , where  $n$  is the frequency of the sound wave.

Since the node-to-node distance is

$$\text{or } \lambda / 2 = 0.08 \quad \text{or } \lambda = 0.16\text{m}$$

$$(i) \quad v = f\lambda \quad \therefore v = 2000 \times 0.16 = 320 \text{ m/s}$$

$$(ii) \quad 320 = 1600 \times \lambda \quad \text{or } \lambda = 0.2 \text{ m}$$

$$\therefore \text{Distance between nodes} = 0.2/2 = 0.1 \text{ m} = 10 \text{ cm}$$

(iii) Since there are nodes at the ends, the distance between the closed end and the diaphragm must be an integral multiple of  $\lambda/2$

$$\therefore L = n\lambda / 2 = n \times 0.2 / 2 = n' \times 0.16 / 2$$

$$\Rightarrow \frac{n}{n'} = \frac{4}{5} \quad \text{when } n' = 5, n = 4$$

$$L = \frac{n' \times 0.16}{2} = 0.4 \text{ m} = 40 \text{ cm}$$

(iv) For the next lower frequency  $n = 3, 2, 1$

$$\therefore 0.4 = 3\lambda / 2 \quad \text{or } \lambda = 0.8/3$$

$$\text{since } v = f\lambda, f = \frac{320}{0.8/3} = 1200\text{Hz}$$

$$\therefore f = 320 / 0.4 = 800\text{Hz}$$

$$\text{again } 0.4 = 1\lambda / 2 \quad \text{or } \lambda = 0.4\text{m}$$

$$\therefore n = 320 / 0.4 = 800\text{Hz}$$

**Example 2:** A tuning fork of frequency 256 Hz and an open orange pipe of slightly lower frequency are at 17°C. When sounded together, they produce 4 beats per second. On altering the temperature of the air in the pipes, it is observed that the number of beats per second first diminishes to zero and then increases again to 4. By how much and in what direction has the temperature of the air in the pipe been altered?

**Sol:** In a open organ pipe the frequency of the wave is  $n = \frac{V_t}{\lambda}$  where  $V_t$  is the velocity of wave at temperature  $t$  and  $\lambda = 2L$  is the wavelength of the vibrating wave. If temperature of air inside the organ pipe changes, the velocity of wave also changes, since  $V \propto \sqrt{T}$ .

$$n = \frac{V_{17}}{2L} \quad \text{where } L = \text{length of the pipe}$$

$$\therefore 256 - \frac{V_{17}}{2L} = 4 \quad \text{or } \frac{V_{17}}{2L} = 252$$

Since beats decrease first and then increase to 4, the frequency of the pipe increases. This can happen only if the temperature increases.

Let  $t$  be the final temperature, in Celsius,

$$n = \frac{V_t}{2L} - 256 = 4 \quad \text{or } \frac{V_t}{2L} = 260$$

$$\text{dividing } \frac{V_t}{V_{17}} = \frac{260}{252} \quad \text{or } \sqrt{\frac{273+t}{273+17}} = \frac{260}{252}$$

$$\left( \because V \propto \sqrt{T} \right) \quad \text{or } t = 308.7 - 273 = 35.7 - 17 = 18.7^\circ\text{C.}$$

$$\therefore \text{Rise in temperature} = 35.7 - 17 = 18.7^\circ\text{C.}$$

**Example 3:** Find the fundamental and the first overtone of a 15 cm pipe

(a) If the pipe is closed at one end,

(b) If the pipe is open at both ends,

(c) How many overtones may be heard by a person of normal hearing in each of the above cases? Velocity of sound in air = 330 ms<sup>-1</sup>

**Sol:** For the organ pipe closed at one end, the fundamental frequency of the wave of wavelength  $\lambda$  is given by,  $n_0 = \frac{v}{4L}$ . The frequency of  $i^{\text{th}}$  overtone is given by  $n_i = (i+1) \times n_0$  where  $i=1,2,3,\dots$  etc.

(a)  $n_0 = \frac{v}{4L}$  where  $n_0 =$  frequency of the

$$\text{fundamental} \Rightarrow n_0 = \frac{330}{4 \times 0.15} = 550 \text{ Hz}$$

(b) The first four overtones are  $2n_0, 3n_0, 4n_0,$  and  $5n_0$ . So, the required frequencies are 1100, 2200, 3300, 4400, and 5500 Hz.

(c) the frequency of the  $n^{\text{th}}$  overtone is  $(2n + 1)n_0$

$$\therefore (2n+1)n_0 = 20000; \text{ or } (2n+1)550 = 20000$$

$$\text{or } n = 17.68$$

Or  $n = 17.18$  the acceptable value is 17.

**Example 4:** The wavelength of the note emitted by a tuning fork of frequency 512 Hz in air at  $17^\circ \text{C}$  is 66.6 cm. If the density of air at STP is 1.293 gram per liter, calculate  $\gamma$  for air.

**Sol:** The bulk modulus of gas  $\gamma$  is given by  $\gamma = \frac{v^2 p}{P_0}$ .

Here  $v$  is velocity of wave, and  $p$  is the pressure at a point. And  $P_0$  is the atmospheric pressure.

$$n = 512 \text{ Hz, } \lambda = 66.6 \text{ cm}; \quad v = n\lambda$$

$$= 512 \times 66.6 = 340.48 \text{ m/s}; \quad \gamma = \frac{v^2 p}{P_0}$$

$$P_0 = 1.013 \times 10^5 \text{ Nm}^{-2}; \quad p = 1.293 \text{ kg/m}^3;$$

$$\therefore \gamma = \frac{(330)^2 \times 1.293}{1.013 \times 10^5} = 1.39.$$

**Example 5:** A source of sound is moving along orbit of radius 3 m with an angular velocity of 10 rad/s. A source detector located far away from the source is executing linear simple harmonic motion along the line BD as shown in the figure with an amplitude  $BC = CD = 6$  m. The frequency of oscillation of the detector is  $5/\pi$  per second. The source is at the point A when the detector is at the point B. If the source emits a continuous wave of frequency 340 Hz, then find the maximum and the minimum frequency recorded by the detector.

**Sol:** Here both source and detector are performing periodic motion. When source and detector are moving away from each other, the detector will record the minimum frequency and vice versa.

Speed of source,  $V_s = r\omega = 3 \times 10 = 30 \text{ m/s}$

Maximum velocity of detector  $v_0 = A\omega'$

$$v_0 = A \times 2\pi f' = 6 \times 2\pi \times (5/\pi) = 60 \text{ m/s}$$

Actual frequency of source  $n = 340 \text{ Hz}$

The frequency recorded by the detector is maximum when both the source and detector travel along the same direction.

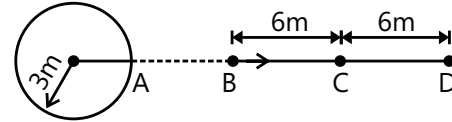

$$n_{\text{max}} = \frac{v + v_0}{v + v_s} n = \frac{330 + 60}{330 - 30} \times 340 = 442 \text{ Hz}$$

The frequency recorded will be minimum when both the source and detector are travelling in opposite directions.

$$n_{\text{min}} = \frac{v + v_0}{v + v_s} n = \frac{330 - 60}{330 + 30} \times 340 = 255 \text{ Hz}$$

## JEE Advanced/Boards

**Example 1:** Two sources  $S_1$  and  $S_2$  separated by 2.0 m, vibrate according to equation

$$y_1 = 0.03 \sin(\pi t) \quad \text{and} \quad y_2 = 0.02 \sin(\pi t)$$

Where  $y_1, y_2$  and  $t$  are in M.K.S. units. They send out waves of velocity 1.5m/s.

Calculate the amplitude of the resultant motion of the particle collinear with  $S_1$  and  $S_2$  and located at a point.

(a) To the right of  $S_2$

(b) To the left of  $S_1$  and

(c) In the middle of  $S_1$  and  $S_2$

**Sol:** The phase difference between the two waves is given by  $\phi = \frac{2\pi x}{\lambda}$  where  $x = 2.0$  m is the path difference between the two waves at points near to  $S_1$  or  $S_2$ .

The resultant amplitude of the superimposed wave is

$$a = \sqrt{a_1^2 + a_2^2 + 2a_1 a_2 \cos \phi}$$

Let P and R be respective points to the left of  $S_1$  and right of  $S_2$ , respectively.

The oscillations  $y_1$  and  $y_2$  have amplitude  $a_1 = 0.03$  m and  $a_2 = 0.02$  m, respectively. These have equal period

$$T = 2 \text{ s and same frequency } n = \frac{1}{T} = \frac{1}{2} = 0.5 \text{ s}^{-1}.$$

The wavelength of each vibration

$$\lambda = \frac{v}{n} = \frac{1.5}{0.5} = 3.0\text{m}$$

(a) The path difference for point R to the

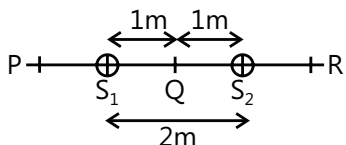

right of  $S_2 = \Delta = (S_1R - S_2R) = S_1S_2 = 2\text{m}$

$$\therefore \text{Phase difference } \phi = \frac{2\pi}{\lambda}x = \frac{2\pi}{3} \times 2.0 = \frac{4\pi}{3}$$

The resultant amplitude for point R is given by

$$\sqrt{a_1^2 + a_2^2 + 2a_1a_2 \cos \phi} = \sqrt{\{(0.03)^2 + (0.02)^2 + 2 \times 0.03 \times 0.02 \times \cos(4\pi/3)\}}$$

Solving, we obtain  $a = 0.02565\text{ m}$ .

(b) The path difference for all point p to the left of  $S_1$  is  $\Delta = S_2P - S_1P = 2.0\text{ m}$ .

Hence, the resultant amplitude for all points to the left of  $S_1$  is  $0.0265\text{ m}$ .

(c) for a point Q, midway between  $S_1$  and  $S_2$ , the path difference is zero i.e.,  $\phi = 0$

$$\begin{aligned} \text{Hence } a &= \sqrt{a_1^2 + a_2^2 + 2a_1a_2} \\ &= \sqrt{\{(0.03)^2 + (0.02)^2 + 2(0.03)(0.02)\}} \\ &= 0.03 + 0.02 = 0.05\text{m} \end{aligned}$$

**Example 2:** A progressive and stationary simple harmonic wave each have the same frequency of 250 Hz, and the same velocity of 30 m/s. Calculate

(a) The phase difference between two vibrating points on the progressive waves which are 10 cm apart.

(b) The equation of motion of the progressive wave if its amplitude is 0.03 m.

(c) The distance between nodes in the stationary wave,

(d) The equation of motion of the stationary wave if its amplitude is 0.01 m.

**Sol:** The simple harmonic progressive waves, is represented by  $y = a \sin \omega \left( \frac{t}{T} - \frac{x}{\lambda} + \phi \right)$  where  $\phi$  is the phase constant of the wave. The phase difference is

$\delta = \frac{2\pi}{\lambda} \Delta x$  where wavelength is  $\lambda$  and  $\Delta x$  is the path difference. The distance between two successive node or two successive antinode is  $\lambda/2$ .

Given,  $n = 250\text{ Hz}$ ,  $v = 30\text{ m/s}$

given,  $n = 250\text{ Hz}$ ,  $v = 30\text{ m/s}$

$$\therefore \lambda = \frac{v}{n} = \frac{30}{250} = \frac{3}{25}\text{m} = 12\text{cm}$$

(a)  $\therefore$  Phase difference for a distance of 10 cm

$$= \frac{2\pi}{\lambda} \times 10 = \frac{2\pi}{12} \times 10 = \frac{5\pi}{3}$$

(b) Now  $a = 0.03\text{m}$ ,  $\lambda = (3/25)\text{m}$

and  $\frac{1}{T} = n = 250\text{Hz}$

The equation of a plane progressive

wave is given by  $y = a \sin 2\pi \left( \frac{t}{T} - \frac{x}{\lambda} + \phi \right)$

$\therefore$  where  $\phi$  is initial phase;

$$y = 0.03 \sin 2\pi (250t - 25x/3 + \phi) ;$$

(c) The distance between nodes in stationary

$$\text{wave} = \frac{\lambda}{2} = \frac{12}{6} = 6\text{ cm}$$

(d) Equation of a stationary wave is given by

$$y = 2a \cos \frac{2\pi x}{\lambda} \sin \frac{2\pi vt}{\lambda}$$

If there is antinode at  $x = 0 = 2a \cos \frac{2\pi x}{\lambda} \sin$

As  $a = 0.01\text{m}$ ,  $\lambda = \frac{3}{25}\text{m}$  and  $\frac{1}{T} = 250\text{ Hz}$

$$y = 0.02 \cos \left( \frac{50\pi x}{3} \right) \sin (500\pi t)\text{m where } x \text{ and } y \text{ are in meter and } t \text{ in sec}$$

**Example 3:** The first overtone of an open organ pipe beats with the first overtone of a closed organ pipe with a beat frequency of 2.2 Hz. The fundamental frequency of the closed organ pipe is 110 Hz. Find the length of the pipes.

**Sol:** The difference in frequencies of the first overtones of the open organ pipe and closed organ pipe is 2.2 Hz. Write the frequencies in terms of length of the pipes and get the relation between the lengths of the pipes. The fundamental frequency of the closed organ pipe is given so its length can be easily found.

The beats are produced when the waves of same amplitude but different frequencies, resonate with each other.

Let the length of open and closed pipes be  $l_1$  and  $l_2$ , respectively.

The frequency of first overtone of open organ pipe is

$$n_1 = \frac{2v}{2l_1} = \frac{v}{l_1}$$

The frequency of first overtone of closed organ pipe is

$$n_2 = \frac{3v}{4l_2}$$

Fundamental frequency of closed organ pipe

$$n = \frac{v}{4l_2}; \therefore \frac{v}{4l_2} = \frac{330}{4l_2} = 110$$

$$l_2 = \frac{330}{4 \times 110} = 0.75 \text{ m}$$

As beat frequency = 2.2 Hz

$$= \frac{v}{l_1} - \frac{3v}{4l_2} \Rightarrow \frac{330}{l_1} - \frac{3 \times 330}{4 \times 0.75} = 2.2$$

$$\therefore l_1 = \frac{330}{332.2} = 0.993 \text{ m};$$

$$\text{Beat frequency} = \frac{3v}{4l_2} - \frac{v}{l_1} = 2.2$$

$$\text{or } \frac{3 \times 330}{4 \times 0.75} - \frac{330}{l_1} = 2.2; \quad \frac{330}{l_1} = 327.8$$

$$l_1 = 1.006 \text{ m.}$$

**Example 4:** The speed of sound in hydrogen is 1270 m/s. Calculate the speed of sound in the mixture of oxygen and hydrogen in which they are mixed in 1:4 ratio.

**Sol:** The density of the mixture is given as  $\rho = \frac{V_1\rho_1 + V_2\rho_2}{V_1 + V_2}$

here  $V_1:V_2 = 1:4$ . The speed of sound in gas is  $v \propto \sqrt{\frac{1}{\rho}}$ .

Let  $V_1$  and  $V_2$  be respective volume of oxygen and hydrogen.

Let  $d_1, m_1$  be density and mass of oxygen in the mixture and  $d_2, m_2$  be density and mass of hydrogen in the mixture, respectively.

$$\therefore \rho = \frac{\text{Total mass}}{\text{total volume}} = \frac{V_1\rho_1 + V_2\rho_2}{V_1 + V_2}$$

$$= \frac{V_2\rho_2(V_1\rho_1 / V_2\rho_2 + 1)}{V_2(V_1 / V_2 + 1)} = \frac{d_2(V_1\rho_1 / V_2\rho_2 + 1)}{(V_1 / V_2 + 1)}$$

$$\therefore V_1 / V_2 = 1/4 \text{ and } \frac{\rho_1}{\rho_2} = \frac{32}{2} = 16$$

$$\therefore \rho = \frac{\rho_2 \left( \frac{1}{4} \times 16 + 1 \right)}{\left( \frac{1}{4} + 1 \right)} = 4\rho_2 \Rightarrow \frac{\rho}{\rho_2} = 4.$$

Let  $V_1$  and  $V_2$  be the speed of sound in the mixture and hydrogen, respectively.

$$v_1 = \sqrt{\frac{\gamma P}{\rho_1}} \text{ and } v_2 = \sqrt{\frac{\gamma P}{\rho_2}}; \therefore \frac{v_1}{v_2} = \sqrt{\frac{\rho_2}{\rho_1}}$$

$$= \sqrt{4} = 2 \text{ or } v_1 = \frac{v_2}{2} = \frac{1270}{2} = 635 \text{ m/sec}$$

**Example 5:** The difference between the apparent frequency of a source as perceived by an observer during its approaching and recession is 2% of the natural frequency of the source. Find the velocity of the source. Take the velocity of sound as 350 m/s.

**Sol:** By the Doppler's method use the formula for apparent frequency in terms of source velocity to express the difference in two frequencies of approach and recession of the source in terms of its velocity.

For the source approaching a stationary observer,

$$n' = n \left[ \frac{v}{v - v_s} \right]; \text{ As } v \gg v_s,$$

$$n' = n \left[ \frac{1}{1 - (v_s / v)} \right] = n \left[ 1 + \frac{v_s}{v} \right]^{-1}$$

$$\therefore n' \approx n \left[ 1 + \frac{v_s}{v} \right] \quad \dots(i)$$

When the source is receding, then

$$n'' \approx n \left[ 1 - \frac{v_s}{v} \right] \quad \dots(ii)$$

From Eqs. (i) and (ii)

$$n' - n'' = \left[ 1 + \frac{v_s}{v} \right] - \left[ 1 - \frac{v_s}{v} \right] = \frac{2nv_s}{v}$$

$$\text{Or } \frac{n' - n''}{n} = \frac{2v_s}{v}$$

$$\text{Percentage change in frequency} = \left( \frac{2v_s}{v} \right) \times 100 = 2$$

$$\text{Or } v_s = 3.5 \text{ m/s}; \frac{2nv_s}{v} \times 100 = 2$$

**Example 6:** A whistle emitting a sound of frequency 440 Hz is tied to a string of 1.5 m length and rotates with an angular velocity of 20 rad/s in the horizontal plane. Calculate the range of frequency heard by an observer stationed at a large distance from the whistle.

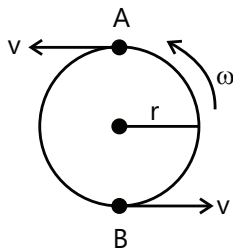

**Sol:** As the whistle is moved in the circle in horizontal plane, it sometimes moves away and sometimes towards the stationary observer. Thus the observer will

hear the minimum frequency of  $n_{\min} = n \left( \frac{v}{v + v_s} \right)$  when

whistle is moving away from him. The observer will

hear maximum frequency of  $n_{\max} = n \left( \frac{v}{v - v_s} \right)$  when

the whistle is moving towards him.

Velocity of source  $= v_s = r\omega = 1.5 \times 20 = 30$  m/s

Frequency  $n = 440$  Hz.

And speed of sound,  $v = 330$  m/s, the maximum frequency  $n_{\max}$  will correspond to a position when source is approaching the observer

$$n_{\max} = n \left( \frac{v}{v - v_s} \right) = 440 \left( \frac{330}{330 - 30} \right)$$

$$= \frac{440 \times 330}{300} = 484$$

The minimum frequency  $n_{\min}$  will correspond to a position when source is receding the observer.

$$n_{\min} = n \left( \frac{v}{v + v_s} \right) = 440 \left( \frac{330}{330 + 30} \right)$$

$$= \frac{440 \times 330}{360} = 403 \text{ Hz}$$

The range of frequency is from 403 Hz to 484 Hz.

**Example 7:** A train approaching a hill at a speed of 40 km/hr. sounds its horn of frequency 580 Hz when it is at a distance of 1 km from the hill. A wind with a speed of 40 km/hr is blowing in the direction of motion of the train. Find

(a) The frequency of the horn as heard by the observer on the hill,

(b) The distance from the hill at which the echo from the hill is heard by the driver and its frequency (velocity of sound in air 1,200 km/hr.)

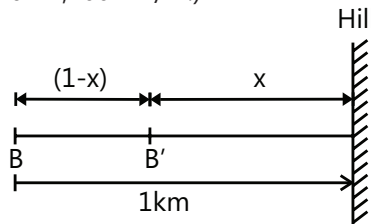

**Sol:** As train is moving towards the stationary observer on the hill. And the wind is in direction of the motion of train, the frequency of the sound waves from horn

heard to the observer on hill is given by  $n' = n \left[ \frac{v'}{v' - v_s} \right]$

where  $v' = v + w$  (sum of velocities of train and wind).

When this sound wave reflects from the hill, and travels towards the moving train, the frequency heard by the

driver is  $n' = n \left[ \frac{v - w + v_s}{(v - w)} \right]$ .

(a) The apparent frequency is given by

$$n' = n \left[ \frac{v + w}{(v + w) - v_s} \right]$$

$V = 1200$  km/hr.,  $w = 40$  km/hr.,  $v_s = 40$  km/hr. and  $n = 580$  Hz.

$$\therefore n' = 580 \left[ \frac{1200 + 40}{(1200 + 40) - 40} \right] = 599.3 \text{ Hz}$$

(b) As shown in the figure, let the driver hear the echo when he is at a distance  $x$  km from the hill. Time taken by the train to reach the point B'

$$t = \frac{(1-x)}{\text{velocity of train}} = \frac{1-x}{40} \text{ hr};$$

Time taken by the sound to reach the point B'

$$t = \frac{x}{\text{velocity of sound} - \text{velocity of wind}} = \frac{x}{1200 - 40} \text{ hr}$$

$$\frac{1-x}{40} = \frac{x}{1200 - 40}; x = 0.966 \text{ km}$$

Frequency heard by driver.

$$n' = 580 \left[ \frac{1200 - 40 + 40}{(1200 - 40)} \right] = 600 \text{ Hz}$$

**Example 8:** A band playing music at frequency  $f$  is moving toward a wall with velocity  $V_s$ . A motorist is following the band with a speed of  $V_m$ . If  $V$  is speed of sound, obtain an expression for the beat frequency heard by the motorist.

**Sol:** In this case, both the source and the observer moving with different speeds towards the wall so the frequency of sound heard by motorist is given as

$$f' = f_0 \left[ \frac{v + v_m}{v + v_s} \right]$$

While the sound reflected from the wall is moving towards the motorist. Hence the frequency heard by

the motorist will be  $f'' = f_w \left[ \frac{v + v_m}{v} \right]$ . These two waves

superimpose with each other to create beats and number of beats heard is given by  $n = f'' - f'$ .

The frequency,  $f$ , of band heard by the motorist directly is given by

$$f' = f \left[ \frac{v + v_m}{v + v_s} \right]$$

The frequency  $f_w$  reaching the wall is

$$f_w = f \left[ \frac{v + 0}{v + v_s} \right] = f \left[ \frac{v}{v - v_b} \right]$$

The frequency  $f''$  reaching the motorist is given by

$$f'' = f_w \left[ \frac{v + v_m}{v + 0} \right] = f \left[ \frac{v}{v - v_b} \right] \left[ \frac{v + v_m}{v} \right]$$

$$= f \left[ \frac{v + v_m}{v - v_b} \right] \therefore \text{Beat frequency} = f'' - f' = \Delta f$$

$$\therefore \Delta f = f \left[ \frac{v + v_m}{v - v_b} \right] - f \left[ \frac{v + v_m}{v + v_b} \right];$$

$$= f \left[ \frac{(v + v_m)(v + v_b) - (v + v_m)(v - v_b)}{(v^2 - v_b^2)} \right]$$

$$= f \left[ \frac{(v + v_m)(2v_b)}{(v^2 - v_b^2)} \right]$$

## JEE Main/Boards

### Exercise 1

**Q.1** The velocity of sound in air at NTP is  $331 \text{ ms}^{-1}$ . Find its velocity when the temperature rises to  $91^\circ\text{C}$  and its pressure is doubled.

**Q.2** A displacement wave is represented by  $\xi = 0.25 \times 10^{-3} \sin(500t - 0.025x)$

Deduce (i) amplitude (ii) period (iii) angular frequency (iv) Wavelength (v) amplitude of particle velocity (vi) amplitude of particle acceleration.  $\xi$ ,  $t$  and  $x$  are in cm, sec and meter respectively.

**Q.3** Calculate the velocity of sound in gas, in which two wave lengths 2.04m and 2.08m produce 20 beats in 6 seconds.

**Q.4** What type of mechanical wave do you expect to exist in (a) vacuum (b) air (c) inside the water (d) rock (e) on the surface of water?

**Q.5** What will be the speed of sound in a perfectly rigid rod?

**Q.6** A stone is dropped into a well in which water is 78.4m deep. After how long will the sound of splash be heard at the top? Take velocity of sound in air =  $332 \text{ ms}^{-1}$

**Q.7** From a cloud at an angle of  $30^\circ$  to the horizontal, we hear the thunder clap 8 s after seeing the lightening flash. What is the height of the cloud above the ground if the velocity of sound in air is 330 m/s?

**Q.8** A fork of frequency 250Hz held over tube and maximum sound is obtained when the column of air is 31cm or 97 cm. Determine (i) velocity of sound (ii) the end correction (iii) the radius of tube.

**Q.9** In an experiment, it was found that a tuning fork and a sonometer gave 5 beats/sec, both when length of wire was 1m and 1.05m. Calculate the frequency of the fork.

## Exercise 2

### Single Correct Choice Type

**Q.1** A firecracker exploding on the surface of lake is heard as two sounds at a time interval  $t$  apart by a man on a boat close to water surface. Sound travels with a speed  $u$  in water and a speed  $v$  in air. The distance from the exploding firecracker to the boat is

- (A)  $\frac{utv}{u+v}$                       (B)  $\frac{t(u+v)}{uv}$   
 (C)  $\frac{t(u-v)}{uv}$                       (D)  $\frac{utv}{u-v}$

**Q.2** A sonometer wire has a total length of 1 m between the fixed ends. Two wooden bridges are placed below the wire at a distance  $1/7$ m from one end and  $4/7$ m from the other end. The three segments of the wire have their fundamental frequencies in the ratio:

- (A) 1: 2: 3                      (B) 4: 2: 1  
 (C) 1:  $1/2$ :  $1/3$                       (D) 1: 1: 1

**Q.3** A person can hear frequencies only up to 10 kHz. A steel piano wire 50 cm long of mass 5 g is stretched with a tension of 400 N. The number of the highest overtone of the sound produced by this piano wire that the person can hear is

- (A) 4                      (B) 50                      (C) 49                      (D) 51

**Q.4** How many times intense is 90 dB sound than 40dB sound?

- (A) 5                      (B) 50                      (C) 500                      (D)  $10^5$

**Q.5** At a prayer meeting, the disciples sing jai-ram jai-ram. The sound amplified by a loudspeaker comes back after reflection from a builder at a distance of 80m from the meeting. What maximum time interval can be kept between one jai-ram and the next jai-ram so that the echo does not disturb a listener sitting in the meeting? Speed of sound in air is  $320 \text{ ms}^{-1}$ .

- (A) 20 Seconds                      (B) 0.3 Seconds  
 (C) 40 Seconds                      (D) 0.5 Seconds

**Q.6** A man stands before a large wall at a distance of 50.0 m and claps his hands at regular intervals. Initially, the interval is large. He gradually reduces the interval and fixes it at a value when the echo of a clap merges

with the next clap 10 times during every 3 seconds. Find the velocity of sound in air.

- (A) 420 m/s                      (B) 333 m/s  
 (C) 373 m/s                      (D) 555 m/s

**Q.7** Find the minimum and maximum wavelength of sound in water that is in the audible range (20-20000 Hz) for an average human ear. Speed of sound in water =  $1450 \text{ ms}^{-1}$ .

- (A) 72.5 m                      (B) 70.5 m                      (C) 71.5 m                      (D) 70.9 m

**Q.8** The sound level at a point 5.0 m away from a point source is 40 dB. What will be the level at a point 50 m away from the source?

- (A) 25 lb                      (B) 5 lb                      (C) 20 db                      (D) 40 lb

**Q.9** A source of sound S and a detector D are placed at some distance from one another. A big cardboard is placed near the detector and perpendicular to the line SD as shown in figure. It is gradually moved away and it is shown that the intensity change from a maximum to a minimum as the board is moved through a distance of 20cm. What will be the frequency of the sound emitted. Velocity of sound in air is  $336 \text{ ms}^{-1}$ .

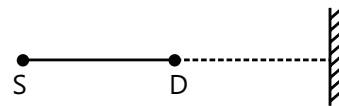

- (A) 420 Hz                      (B) 422 Hz                      (C) 450 Hz                      (D) 410 Hz

**Q.10** Two sources of sound,  $s_1$  and  $s_2$ , emitting waves of equal wavelength 20.0 cm, are placed with a separation of 20.0 cm between them. A detector can be moved on a line parallel to  $s_1 s_2$  and at a distance of 20.0cm from it. Initially, the detector is equidistant from the two sources. Assuming that the waves emitted by the sources are in phase, find the minimum distance through which the detector should be shifted to detect a minimum frequency of sound.

- (A) 12 cm                      (B) 24 cm                      (C) 36 cm                      (D) 48 cm

**Q.11** A cylindrical metal tube has a length of 50 cm and is open at both ends. Find the frequencies between 1000 Hz and 2000 Hz at which the air column in the tube can resonate. Speed of sound in air is  $340 \text{ ms}^{-1}$ .

- (A) 1020 Hz, 1360 Hz, 1700 Hz  
 (B) 1200 Hz, 1400 Hz, 1700 Hz  
 (C) 1020 Hz, 1360 Hz, 2000 Hz  
 (D) 1000 Hz, 1360 Hz, 1800 Hz

**Q.12** The first overtone frequency of a closed organ pipe  $p_1$  is equal to the fundamental frequency of an open organ pipe  $p_2$ . If the length of the pipe  $p_1$  is 30cm. What will be the length of  $p_2$ ?

- (A) 12 cm (B) 24 cm (C) 20 cm (D) 38 cm

### Previous Years' Questions

**Q.1** A siren placed at a railway platform is emitting sound of frequency 5 kHz. A passenger sitting in a moving train A records a frequency of 5.5kHz, while the train approaches the siren. During his return journey in a different train B, he records a frequency of 6.0 kHz while approaching the same siren. The ratio of the train B to that of train A is **(2002)**

- (A) 242/252 (B) 2  
(C) 5/6 (D) 11/6

**Q.2** A sonometer wire resonates with a given tuning fork forming standing waves with five antinodes between the two bridges when a mass of 9 kg is suspended from the wire. When this mass is replaced by mass M, the wire resonates with the same tuning fork forming three nodes and antinodes for the same position of the bridges. The value of M is **(2002)**

- (A) 25kg (B) 5kg  
(C) 12.5kg (D) 1/25kg

**Q.3** In the experiment for the determination of the speed of sound in air using the resonance column method, the length of air column that resonates in the fundamental mode, with a tuning fork is 0.1m. When this length is changed to 0.35 m, the same tuning fork resonates with the first overtone. Calculate the end correction. **(2003)**

- (A) 0.012m (B) 0.025m  
(C) 0.05 m (D) 0.024

**Q.4** A source of sound of frequency 600Hz is placed inside water. The speed of sound in water is 1500m/s and in air it is 300m/s. the frequency of sound recorded by an observer who is standing in air is **(2004)**

- (A) 200Hz (B) 3000Hz  
(C) 120 Hz (D) 600 Hz

**Q.5** A vibrating string of certain length  $l$  under a tension  $T$  resonates with a mode corresponding to the first

overtone (third harmonic) of an air column of length 75 cm inside a tube closed at one end. The string also generates 4 beats/s when excited along with a tuning fork of frequency  $n$ . Now when the tension of the string is slightly increased, the number of beats reduces to 2 per second. Assuming the velocity of sound in air to be 340 m/s, the frequency  $n$  of the tuning fork in Hz is **(2008)**

- (A) 344 (B) 336  
(C) 117.3 (D) 109.3

**Q.6** A police car with a siren of frequency 8 kHz is moving with uniform velocity 36 km/h toward a tall building which reflects the sound waves. The speed of sound in air is 320m/s. The frequency of the siren by the car driver is **(2011)**

- (A) 8.50 kHz (B) 8.25 kHz  
(C) 7.75 kHz (D) 7.50 kHz

**Q.7** Sound waves of frequency 660 Hz fall normally on a perfectly wall. The shortest distance from the wall at which the air particle have maximum amplitude of vibration is.....m. speed of sound =330m/s. **(1984)**

**Q.8** In a sonometer wire, the tension is maintained by suspending a 50.7kg mass from the free end of the wire. The suspended mass has a volume of 0.0075m<sup>3</sup>. The fundamental frequency of vibration of the wire is 260 Hz. If the suspended mass is completely submerged in water, the fundamental frequency will become.....Hz. **(1987)**

**Q.9** The ratio of the velocity of sound in hydrogen gas  $\left(\gamma = \frac{7}{5}\right)$  to that in helium gas  $\left(\gamma = \frac{5}{3}\right)$  at the same temperature is  $\sqrt{21/5}$ . State whether true or false **(1983)**

**Q.10** A plane wave of sound travelling in air is incident upon a plane water surface. The angle of incidence is 60°. Assuming Snell's law to be valid for sound waves, it follows that the sound wave will be refracted into water away from the normal. State whether true or false **(1984)**

**Q.11** A source of sound wave with frequency 256 Hz is moving with a velocity  $v$  towards a wall and an observer is stationary between the source and the wall.



When the observer is between the source and the wall, he will hear beats. State whether true or false (1985)

**Q.12.** While measuring the speed of sound by performing a resonance column experiment, a student gets the first resonance condition at a column length of 18 cm during winter. Repeating the same experiment during summer, she measures the column length to be  $x$  cm for the second resonance. Then (2008)

- (A)  $18 > x$                       (B)  $x > 54$   
 (C)  $54 > x > 36$                 (D)  $36 > x > 18$

**Q.13** A motor cycle starts from rest and accelerates along a straight path at  $2 \text{ m/s}^2$ . At the starting point of the motor cycle there is a stationary electric siren. How far has the motor cycle gone when the driver hears the frequency of the siren at 94% of its value when the motor cycle was at rest? (speed of sound =  $330 \text{ ms}^{-1}$ ). (2009)

- (A) 49 m                              (B) 98 m  
 (C) 147 m                             (D) 196 m

**Q.14.** Three sound waves of equal amplitudes have frequencies  $(v - 1)$ ,  $v$ ,  $(v + 1)$ . They superpose to give beats. The number of beats produced per second will be (2009)

- (A) 4                      (B) 3                      (C) 2                      (D) 1

**Q.15.** A cylindrical tube, open at both ends, has a fundamental frequency,  $f$ , in air. The tube is dipped vertically in water so that half of it is in water. The fundamental frequency of the air-column is now (2012)

- (A)  $f$                       (B)  $\frac{f}{2}$                       (C)  $\frac{3f}{4}$                       (D)  $2f$

**Q.16.** An open glass tube is immersed in mercury in such a way that a length of 8 cm extends above the mercury level. The open end of the tube is then closed and sealed and the tube is raised vertically up by additional 46 cm. What will be length of the air column above mercury in the tube now? (Atmospheric pressure = 76 cm of Hg) (2014)

- (A) 16 cm                              (B) 22 cm  
 (C) 38 cm                              (D) 6 cm

**Q.17.** A train is moving on a straight track with speed  $20 \text{ ms}^{-1}$ . It is blowing its whistle at the frequency of 1000 Hz. The percentage change in the frequency heard by a person standing near the track as the train passes him is (speed of sound =  $320 \text{ ms}^{-1}$ ) close to : (2015)

- (A) 6%                      (B) 12%                      (C) 18%                      (D) 24%

**Q.18** A pipe open at both ends has fundamental frequency  $f$  in air. The pipe is dipped vertically in water so that half of it is in water. The fundamental frequency of the air column is now : (2016)

- (A)  $\frac{3f}{4}$                       (B)  $2f$                       (C)  $f$                       (D)  $\frac{f}{2}$

## JEE Advanced/Boards

### Exercise 1

**Q.1** Find the intensity of sound wave whose frequency is 250 Hz. The displacement amplitude of particles of the medium at this position is  $1 \times 10^{-8} \text{ m}$ . The density of the medium is  $\text{kg/m}^3$ , bulk modulus of elasticity of the medium is  $400 \text{ N/m}^2$ .

**Q.2** In a mixture of gases, the average number of degrees of freedom per molecule is 6. The rms speed of the molecules of the gas is  $c$ . Find the velocity of sound in the gas.

**Q.3** The loudness level at a distance  $R$  from a long linear source is found to be 40 dB. At this point, the amplitude of oscillation of air molecules is 0.01 cm. Then find the loudness level & amplitude at a point at distance ' $10R$ ' from the source.

**Q.4** Two identical sounds A and B reach a point in the same phase. The resultant sound is C. The loudness of C is  $n$  dB higher than the loudness of A. Find the value of  $n$ .

**Q.5** Sound of wavelength  $\lambda$  passes through a Quincke's tube which is adjusted to give a maximum intensity  $I_0$ .

Find the distance the sliding tube should be moved to give an intensity  $I_0/2$ .

**Q.6** The first overtone of a pipe closed at one end resonates with the third harmonic of a string fixed at its ends. The ratio of the speed of sound to the speed of transverse wave travelling on the string is 2: 1. Find the ratio of the length of pipe to the length of string.

**Q.7** An open organ pipe filled with air has a fundamental frequency 500Hz. The first harmonic of another organ pipe closed at one end is filled with carbon dioxide has the same frequency as that the first harmonic of the open organ pipe. Calculate the length of each pipe. Assume that the velocity of sound in air and in carbon dioxide to be 330 and 164m/s respectively.

**Q.8** A, B and C are three tuning forks. Frequency of A is 350 Hz. Beats produced by A and B are 5 per second by B and C are 4 per second. When a wax is put on A, beat frequency between A and B is 2Hz and between A and C is 6Hz. Then, find the frequency of B and C respectively.

**Q.9** Tuning fork A when sounded with fork B of frequency 480Hz gives 5 beats per second. When the prongs of A are loaded with wax, it gives 3 beats per second. Find the original frequency of A.

**Q.10** A car is moving towards a huge wall with a speed= $c/10$ , where  $c$ =speed of sound in still air. A wind is also blowing parallel to the velocity of the car in the same direction and with the same speed. If the car sounds a horn of frequency  $f$ , then what is the frequency of the reflected sound of the horn headed by driver of the car?

**Q.11** A fixed source of sound emitting a certain frequency appears as  $f_a$  when the observer is approaching the source with speed  $v$  and frequency  $f_r$  when the observer recedes from the source with same speed. Find the frequency of the source.

**Q.12** Two stationary sources A and B are sounding notes of frequency 680Hz. An observer moves from A to B with a constant velocity  $u$ . If the sound is  $340 \text{ ms}^{-1}$ , what must be the value of  $u$  so that he hears 10 beats per second?

## Exercise 2

### Single Correct Choice Type

**Q.1** Two successive resonance frequencies in an open organ pipe are 1944 Hz and 2592 Hz. What will be the length of the tube. The speed of sound in air is  $324\text{ms}^{-1}$ .

- (A) 20 cm (A) 25 cm (A) 33 cm (A) 16 cm

**Q.2** A piston is fitted in a cylindrical tube of small cross section with the other end of the tube open. The tube resonates with a tuning fork of frequency 412 Hz. The piston is gradually pulled out of the tube and it is found that a second resonance occurs when the piston is pulled out through a distance of 320.0cm. What will be the speed of sound in the air of the tube.

- (A) 328 m/s (B) 300 m/s  
(C) 333 m/s (D) 316 m/s

**Q.3** The fundamental frequency of a closed pipe is 293 Hz when the air in it is at a temperature of  $20^\circ\text{C}$ . What will be its fundamental frequency when the temperature changes to  $22^\circ\text{C}$ ?

- (A) 300 Hz (B) 283 Hz (C) 294 Hz (D) 262 Hz

**Q.4** A tuning fork produces 4 beats per second with another tuning fork of frequency 256Hz. The first one is now loaded with a little wax and the beat frequency is found to increase to 6 per second. What was the original frequency of the tuning fork?

- (A) 252 Hz (B) 220 Hz  
(C) 250 Hz (D) 222 Hz

**Q.5** What will be the frequency of beats produced in air when two sources of sound are activated, one emitting a wavelength of 32 cm and the other 32.2 cm. The speed of sound in air is  $350\text{ms}^{-1}$ .

- (A) 11 Hz (B) 13 Hz (C) 15 Hz (D) 7 Hz

**Q.6** A traffic policeman standing on a road sounds a whistle emitting a frequency of 2.00 kHz. What could be the apparent frequency heard by a scooter-driver approaching the policeman at a speed of  $36.0 \text{ kmh}^{-1}$ ?

- (A) 1181 Hz (B) 1183 Hz  
(C) 1185 Hz (D) 1187 Hz

**Assertion Reasoning Type**

- (A) Statement-I is true, statement-II is true and statement-II is correct explanation for statement-I
- (B) Statement-I is true, statement-II is true and statement-II is not the correct explanation for statement-I
- (C) Statement-I is true, statement-II is false.
- (D) Statement-I is false, statement-II is correct.

**Q.7 Statement-I:** When a closed organ pipe vibrates, the pressure of the gas at the closed end remains constant.

**Statement-II:** In a stationary-wave system, displacement nodes are pressure antinodes, and displacement antinodes are pressure nodes.

**Q.8 Statement-I:** The pitch of wind instruments rises and that of string instruments falls as an orchestra warms up.

**Statement-II:** When temperature rises, speed of sound increases but speed of wave in a string fixed at both ends decreases.

**Previous Years' Questions****Paragraph 1:**

Two plane harmonic sound waves are expressed by the equations  $y_1(x, t) = A \cos(\pi x - 100\pi t)$ ;

(All parameters are in MKS) (2006)

**Q.1** How many times does an observer hear maximum intensity in one second?

- (A) 4      (B) 10      (C) 6      (D) 8

**Q.2** What is the speed of the sound?

- (A) 200 m/s      (B) 180 m/s  
(C) 192 m/s      (D) 96 m/s

**Q.3** At  $x=0$ , how many times is the amplitude of  $y_1+y_2$  zero in one second?

- (A) 192      (B) 48      (C) 100      (D) 96

**Paragraph 2:**

Two trains A and B are moving with a speed 20 m/s and 30 m/s respectively in the same direction on the same straight track, with B ahead of A. The engines are at the front ends. The engine of train A blows a long whistle.

Assume that the sound of the whistle is composed of components varying in frequency from  $f_1=800$  Hz to  $f_2=1120$  Hz, as shown in the figure. The spread in the frequency (highest frequency lowest frequency) is thus 320 Hz. The speed of sound in air is 340 m/s. (2007)

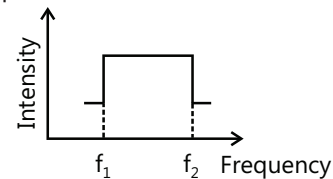

**Q.4** The speed of sound of the whistle is

- (A) 340 m/s for passengers in A and 310 m/s for passengers in B
- (B) 360 m/s for passengers in A and 310 m/s for passengers in B
- (C) 310 m/s for passengers in A and 360 m/s for passengers in B
- (D) 340 m/s for passenger in both the trains.

**Q.5** The distribution of the sound intensity of the whistle as observed by the passenger in train A is best represented by

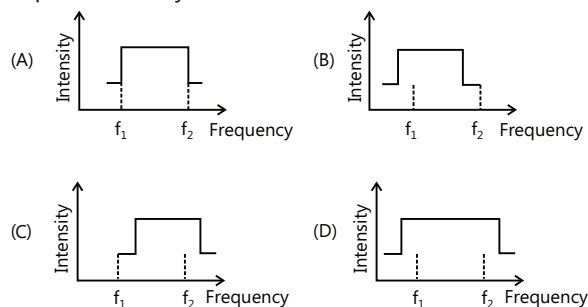

**Q.6** The spread of frequency as observed by the passenger in train B is

- (A) 310 Hz      (B) 330 Hz      (C) 350 Hz      (D) 290 Hz

**Q.7** Velocity of sound in air is 320 m/s. A pipe closed at one end has a length of 1 m. Neglecting end corrections, the air column in the pipe can resonate for sound of frequency (1989)

- (A) 80 Hz      (B) 240 Hz      (C) 320 Hz      (D) 400 Hz

**Q.8** A sound wave of frequency  $f$  travels horizontally to the right and is reflected from a large vertical plane surface moving to left with a speed  $v$ . The speed of sound in medium is  $c$ . (1995)

(A) The number of waves striking the surface per second is  $f \frac{(c+v)}{c}$

(B) The wavelength of reflected wave is  $\frac{c(c-v)}{f(c+v)}$

(C) The frequency of the reflected wave is  $f \frac{(c+v)}{(c-v)}$

(D) The number of beats heard by a stationary listener to the left of the reflecting surface is  $f \frac{v}{c-v}$

**Q.9** A source of sound of frequency 256 Hz is moving rapidly towards a wall with a velocity of 5 m/s. How many beats per second will be heard by the observer on source itself if sound travels at a speed of 330 m/s? (1981)

**Q.10** A source of sound is moving along a circular path of radius 3 m with an angular velocity of 10 rad/s. A sound detector located far away from the source is executing linear simple harmonic motion along the line BD (see figure) with an amplitude BCD = 6 m. The frequency of an oscillation of the detector is  $5/\pi$  per second. The source is at the point A when the detector is at the point B. If the source emits a continuous sound wave of frequency 340 Hz, find the maximum and the minimum frequencies recorded by the detector. (Speed of sound = 340 m/s) (1990)

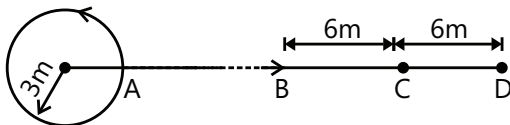

**Q.11** A 3.6 m long pipe resonates with a frequency 212.5 Hz when water level is at a certain height in the pipe. Find the heights of water level (from the bottom of the pipe) at which resonances occur. Neglect end correction. Now the pipe is filled to a height  $H$  ( $\approx 3.6$  m). A small hole is drilled very close to its bottom and water is allowed to leak. Obtain an expression for the rate of fall of water level in the pipe as a function of  $H$ . If the radii of the pipe and the hole are  $2 \times 10^{-2}$  m and  $1 \times 10^{-3}$  m respectively, calculate the time interval between the occurrence of first two resonances. Speed of sound in air is 340 m/s and  $g = 10 \text{ m/s}^2$  (2000)

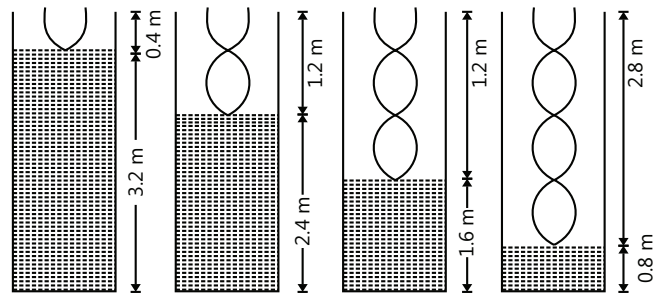

**Q.12** An observer standing on a railway crossing receives frequency of 2.2 kHz and 1.8 kHz when the train approaches and recedes from the observer. Find the velocity of the train. (2005)

(The speed of the sound in air is 300 m/s)

**Q.13** A stationary source is emitting sound at a fixed frequency  $f_0$ , which is reflected by two cars approaching the source. The difference between the frequencies of sound reflected from the cars is 1.2% of  $f_0$ . What is the difference in the speed of the cars (in km per hour) to the nearest? The cars are moving at constant speeds much smaller than the speed of sound which is  $330 \text{ m/s}$ . (2010)

**Q.14** A police car with a siren of frequency 8 kHz is moving with uniform velocity 36 km/hr towards a tall building which reflects the sound waves. The speed of sound in air is 320 m/s. The frequency of the siren heard by the car driver is (2011)

- (A) 8.50 kHz                      (B) 8.25 kHz  
(C) 7.75 kHz                      (D) 7.50 kHz

**Q.15** A person blows into open-end of a long pipe. As a result, a high pressure pulse of air travels down the pipe. When this pulse reaches the other end of the pipe, (2012)

- (A) A high-pressure pulse starts travelling up the pipe, if the other end of the pipe is open.  
(B) A low-pressure pulse starts travelling up the pipe, if the other end of the pipe is open.  
(C) A low-pressure pulse starts travelling up the pipe, if the other end of the pipe is closed.  
(D) A high-pressure pulse starts travelling up the pipe, if the other end of the pipe is closed.

**Q.16** A student is performing an experiment using a resonance column and a tuning fork of frequency  $244 \text{ s}^{-1}$ . He is told that the air in the tube has been replaced by another gas (assume that the column remains filled with the gas). If the minimum height at which resonance occurs is  $(0.350 \pm 0.005)\text{m}$ , the gas in the tube is

(Useful information:  $\sqrt{167RT} = 640 \text{ J}^{1/2} \text{ mole}^{-1/2}$ ;  $\sqrt{140RT} = 590 \text{ J}^{1/2} \text{ mole}^{-1/2}$ . The molar masses  $M$  in grams are given in the options. Take the values of  $\sqrt{\frac{10}{M}}$  for each gas as given there.) **(2014)**

(A) Neon  $\left( M = 20, \sqrt{\frac{10}{20}} = \frac{7}{10} \right)$

(B) Nitrogen  $\left( M = 28, \sqrt{\frac{10}{28}} = \frac{3}{5} \right)$

(C) Oxygen  $\left( M = 32, \sqrt{\frac{10}{32}} = \frac{9}{16} \right)$

(D) Argon  $\left( M = 36, \sqrt{\frac{10}{36}} = \frac{17}{32} \right)$

**Q.17** Two loudspeakers M and N are located 20 m apart and emit sound at frequencies 118 Hz and 121 Hz, respectively. A car is initially at a point P, 1800 m away from the midpoint Q of the line MN and moves towards Q constantly at 60 km/hr along the perpendicular bisector of MN. It crosses Q and eventually reaches a point R, 1800 m away from Q. Let  $v(t)$  represent the beat frequency measured by a person sitting in the car at time  $t$ . Let  $v_P$ ,  $v_Q$  and  $v_R$  be the beat frequencies measured at locations P, Q and R, respectively. The speed of sound in air is 330 m/s. Which of the following statement(s) is(are) true regarding the sound heard by the person? **(2016)**

(A) The plot below represents schematically the variation of beat frequency with time

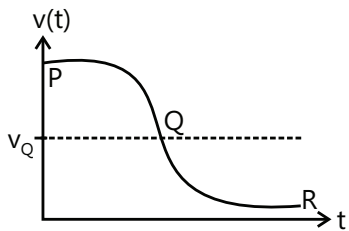

(B)  $v_P + v_R = 2v_Q$

(C) The plot below represents schematically the variation of beat frequency with time

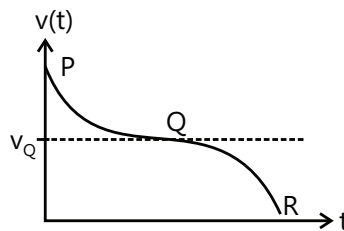

(D) The rate of change in beat frequency is maximum when the car passes through Q.

**Q.18** A student performed the experiment to measure the speed of sound in air using resonance air-column method. Two resonances in the air-column were obtained by lowering the water level. The resonance with the shorter air-column is the first resonance and that with the longer air column is the second resonance. Then, **(2009)**

(A) The intensity of the sound heard at the first resonance was more than that at the second resonance

(B) The prongs of the tuning fork were kept in a horizontal plane above the resonance tube

(C) The amplitude of vibration of the ends of the prongs is typically around 1 cm

(D) The length of the air-column at the first resonance was somewhat shorter than 1/4th of the wavelength of the sound in air

**Q.19.** A hollow pipe of length 0.8 m is closed at one end. At its open end a 0.5 m long uniform string is vibrating in its second harmonic and it resonates with the fundamental frequency of the pipe. If the tension in the wire is 50 N and the speed of sound is  $320 \text{ ms}^{-1}$ , the mass of the string is **(2010)**

(A) 5 grams (B) 10 grams

(C) 20 grams (D) 40 grams

**Q.20** A student is performing the experiment of Resonance Column. The diameter of the column tube is 4 cm. The distance frequency of the tuning fork is 512 Hz. The air temperature is  $38^\circ\text{C}$  in which the speed of sound is resonance occurs, the reading of the water level in the column is **(2012)**

(A) 14.0 (B) 15.2 (C) 16.4 (D) 17.6

**Q.21** Two vehicles, each moving with speed  $u$  on the same horizontal straight road, are approaching each other. Wind blows along the road with velocity  $w$ . One of these vehicles blows a whistle of frequency  $f_1$ . An observer in the other vehicle hears the frequency of the whistle to be  $f_2$ . The speed of sound in still air is  $V$ . The correct statement(s) is (are) **(2013)**

(A) If the wind blows from the observer to the source,  $f_2 > f_1$ .

(B) If the wind blows from the source to the observer,  $f_2 > f_1$ .

(C) If the wind blows from observer to the source,  $f_2 < f_1$ .

(D) If the wind blows from the source to the observer  $f_2 < f_1$ .

**Q.22** Four harmonic waves of equal frequencies and equal intensities  $I_0$  have phase angles  $0, \pi/3, 2\pi/3$  and  $\pi$ . When they are superposed, the intensity of the resulting wave is  $nI_0$ . The value of  $n$  is **(2015)**

## PlancEssential Questions

### JEE Main/Boards

#### Exercise 1

Q. 6      Q.7      Q.8

#### Exercise 2

Q. 1      Q.2      Q.3  
Q.12      Q.13      Q.14  
Q.19      Q.21

### JEE Advanced/Boards

#### Exercise 1

Q. 1      Q.6      Q.8  
Q.12

#### Exercise 2

Q.1      Q.2      Q.3  
Q.8      Q.14      Q.15  
Q.16      Q.24      Q.26

## Answer Key

### JEE Main/Boards

#### Exercise 1

**Q.1**  $382.2 \text{ ms}^{-1}$       **Q.2** (i)  $0.25 \times 10^{-3} \text{ cm}$  (ii)  $\pi / 250 \text{ s}$  (iii)  $500 \text{ rad}$  (iv)  $80\pi \text{ m}$  (v)  $0.125 \text{ cm/s}$  (iv)  $62.5 \text{ cm/sec}^2$

**Q.3**  $353.6 \text{ ms}^{-1}$

**Q.4** (a) No wave (b) longitudinal waves (c) longitudinal (d) transverse or longitudinal or both (separately) (e) combined longitudinal and transverse (ripples)

**Q.5** The speed of sound in a perfectly rigid rod will be infinite

Q.6 4.2 s

Q.7 1.32 km

Q.8  $330 \text{ ms}^{-1}$ , 0.02 m; 0.033 m

Q.9 205 Hz

**Exercise 2****Single correct choice type**

Q.1 D

Q.2 B

Q.3 C

Q.4 D

Q.5 D

Q.6 B

Q.7 A

Q.8 C

Q.9 A

Q.10 A

Q.11 A

Q.12 C

**Previous Years' Questions**

Q.1 B

Q.2 A

Q.3 B

Q.4 D

Q.5 A

Q.6 A

Q.7 0.125

Q.8 240

Q.9 False

Q.10 True

Q.11 False

Q.12 B

Q.13 B

Q.14 C

Q.15 A

Q.16 A

Q.17 B

Q.18 C

**JEE Advanced/Boards****Exercise 1**Q.1  $\frac{\pi^2 \times 10^{-9}}{4} \text{ W/m}^2$ 

Q.2 2C/3

Q.3 30 dB,  $10\sqrt{10} \mu\text{m}$ 

Q.4 6

Q.5  $\lambda/8$ 

Q.6 1:1

Q.7 33 cm and 13.2 cm

Q.8 345, 341 or 349 Hz

Q.9 485 Hz

Q.10 11f/9

Q.11  $\frac{f_r + f_a}{2}$ Q.12  $2.5 \text{ ms}^{-1}$ **Exercise 2****Single Correct Choice Type**

Q.1 B

Q.2 A

Q.3 C

Q.4 A

Q.5 D

Q.6 A

**Assertion Reasoning Type**

Q.7 D

Q.8 A

**Previous Years' Questions**

Q.1 A

Q.2 A

Q.3 C

Q.4 B

Q.5 A

Q.6 A

Q.7 A, B, D

Q.8 A, B, C

Q.9 7.87 Hz

Q.10 438.7 Hz, 257.3 Hz

Q.11 3.2 m, 2.4 m, 1.6 m, 0.8 m,  $-\frac{dH}{dt} = (1.11 \times 10^{-2})\sqrt{H}$ , 43sQ.12  $v_T = 30 \text{ m/s}$ 

Q.13 7

Q.14 A

Q.15 B, D

Q.16 D

Q.17 A, B, D

Q.18 A, D

Q.19 B

Q.20 B

Q.21 A, B

Q.22 3

## Solutions

### JEE Main/Boards

#### Exercise 1

**Sol 1:**  $V' = \sqrt{\frac{4}{3}} V = \sqrt{\frac{4}{3}} \times 331$   
 $= 382.2 \text{ ms}^{-1}$

**Sol 2:** (i)  $A = 0.25 \times 10^{-3} \text{ cm}$

(ii)  $T = \frac{2\pi}{500} = \frac{\pi}{250} \text{ s}$

(iii)  $\omega : 500 \text{ rad/s}$

(iv)  $\lambda = \frac{2\pi}{0.025} \text{ m} = 80\pi \text{ m}$

(v)  $V_{\text{max}} = 0.25 \times 10^{-3} \times 500 \text{ cm s}^{-1}$

$V_{\text{max.}} = 0.125 \text{ cms}^{-1}$

(vi)  $a_{\text{max.}} = V_{\text{max}} \omega = 0.125 \times 500$

$a_{\text{max.}} = 62.5 \text{ cms}^{-2}$

**Sol 3:**  $\frac{V}{2.04} - \frac{V}{2.08} = \frac{20}{6}$

$V \left( \frac{0.04}{2.04 \times 2.05} \right) = \frac{20}{6}$

$V = 353.6 \text{ ms}^{-1}$

**Sol 4:** (a) No wave possible as there is no particle.

(b) Longitudinal waves (direction of motion of particles parallel to direction of propagation of wave)

(c) Longitudinal

(d) Both are possible

(e) Combined longitudinal & transverse (ripples)

**Sol 5:** Infinite as young's modulus of a rigid body is infinite

**Sol 6:**

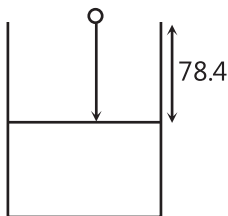

Time to reach water =  $\sqrt{\frac{2 \times 78.4}{9.8}} = 4 \text{ s}$

Time for sound to reach top =  $\frac{78.4}{332} = 0.23 \text{ s}$

Total time = 4.23 s

**Sol 7:**

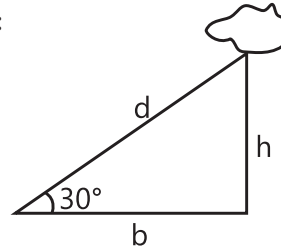

$\Rightarrow d \left( \frac{1}{330} - \frac{1}{3 \times 10^8} \right) = 8$

$\Rightarrow d (3 \times 10^8 - 330) = 8 \times 330 \times 3 \times 10^8$

$\Rightarrow d \cong 8 \times 330$

$\Rightarrow d = 264 \text{ m}$

Height of cloud = 1320 m = 1.32 km

**Sol 8:**  $f = 250 \text{ Hz}$

$\Rightarrow (31 + h) = \frac{\lambda}{2}$

$\Rightarrow (97 + h) = \frac{3\lambda}{4}$

$\Rightarrow 66 = \frac{\lambda}{2}$

$\lambda = 132 \text{ cm}$

$V = f\lambda = 250 \times 1.32 \text{ ms}^{-1}$

$V = 330 \text{ ms}^{-1}$

$H = 132/4 - 31 = 2 \text{ cm} = 0.02 \text{ m}$

Radius of tube =  $\frac{\text{End Cross Section}}{0.6}$

$= \frac{0.02}{0.6} = \frac{0.2}{6} = \frac{0.1}{3} = 0.033 \text{ m}$

**Sol 9:**  $\frac{V}{2} - f = 5$

$F - \frac{V}{2.1} = 5$



$$\frac{V}{2} - \frac{V}{2.1} = 10$$

$$V = 420 \text{ ms}^{-1}$$

$$F = 5 + \frac{420}{2.1} = 205 \text{ Hz}$$

## Exercise 2

### Single Correct Choice Type

**Sol 1: (D)**  $d = u t_0$

$$\Rightarrow d = v(t_0 + t)$$

$$\Rightarrow (v - u)t_0 + vt = 0$$

$$t_0 = \frac{vt}{u - v}$$

$$d = \frac{uvt}{u - v}$$

**Sol 2: (B)**

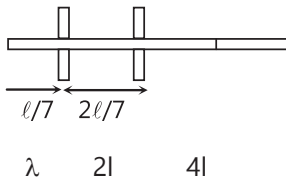

$$\ell = \frac{7\lambda}{2}$$

$$\lambda = \frac{2\ell}{7}$$

$$\lambda \text{ ratio : } 1 : 2 : 4$$

$$v \text{ ratio : } 4 : 2 : 1$$

**Sol 3: (C)**  $\mu = \frac{5 \times 10^{-3}}{0.5} = 0.01$

$$T = 400 \text{ N}$$

$$v = \frac{(n+1)}{2 \times 0.5} \sqrt{\frac{400}{0.01}}$$

$$v = 200(n+1) < 10^4$$

$$\Rightarrow (n+1) < 50$$

$$\Rightarrow n < 49$$

**Sol 4: (D)**  $10 \log \left( \frac{I_2}{I_1} \right) = 50$

$$I_2 = I_1 \times 10^5$$

**Sol 5: (D)** Here given  $S=80\text{m} \times 2=160\text{m}$ .

$$V=320\text{m/s}$$

So the maximum time interval will be

$$T=5/v=160/320=0.5\text{seconds.}$$

**Sol 6: (B)** He has to clap 10 times in 3 seconds.

So time interval between two clap  $= (3/10 \text{ second})$ .

So the time taken go the wall

$$= (3/2 \times 10) = 3/20 \text{ seconds} = 333 \text{ m/s.}$$

**Sol 7: (A)** For minimum wavelength  $n=20 \text{ KHZ}$

$$\Rightarrow v = n\lambda \Rightarrow \lambda = \left( \frac{1450}{20 \times 10^3} \right) = 7.25\text{cm.}$$

(b) For maximum wavelength  $n$  should be minimum

$$\Rightarrow v = n\lambda \Rightarrow \lambda = v/n \Rightarrow 1450/20 = 72.5\text{m.}$$

**Sol 8: (C)** We know that  $\beta = 10 \log_{10} \left( \frac{I}{I_0} \right)$

$$\beta_A = 10 \log \frac{I_A}{I_0}, \beta_B = 10 \log \frac{I_B}{I_0}$$

$$\Rightarrow I_A / I_0 = 10^{(\beta_A/10)} \Rightarrow I_B / I_0 = 10^{(\beta_B/10)}$$

$$\Rightarrow \frac{I_A}{I_B} = \frac{r_B^2}{r_A^2} = \left( \frac{50}{5} \right)^2 \Rightarrow 10^{(\beta_A - \beta_B)} = 10^2$$

$$\Rightarrow \frac{\beta_A - \beta_B}{10} = 2 \Rightarrow \beta_B = 40 - 20 = 20\text{dB}$$

**Sol 9 (A)** According to the given data

$$V=336\text{m/s,}$$

$\lambda/4$  = distance between maximum and minimum intensity

$$= (20\text{cm}) \Rightarrow \lambda = 80\text{cm}$$

$$\Rightarrow n = \text{frequency} = \frac{V}{\lambda} = \frac{336}{80 \times 10^{-2}} = 420\text{Hz.}$$

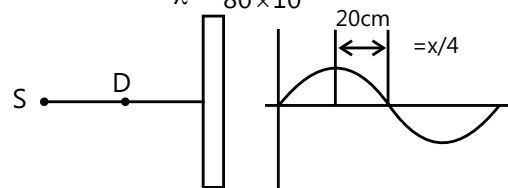

**Sol 10: (A)** According to the data

$$\lambda = 20\text{cm}, S_1 S_2 = 20\text{cm}, BD = 20\text{cm}$$

Let the detector is shifted to left for a distance  $x$  for hearing the minimum sound.

So path difference  $AI=BC-AB$

$$= \sqrt{(20)^2 + (10+x)^2} - \sqrt{(20)^2 + (10-x)^2}$$

So the minimum distances hearing for minimum

$$= \frac{(2n+1)\lambda}{2} = \frac{\lambda}{2} = \frac{20}{2} = 10\text{cm}$$

$$\Rightarrow \sqrt{(20)^2 + (10+x)^2} - \sqrt{(20)^2 + (10-x)^2} = 10$$

Solving we get  $x=12.0\text{ cm}$ .

**Sol 11: (A)** Here given that  $l=50\text{cm}$ ,  $v=340\text{m/s}$

As it is an open organ pipe, the fundamental frequency  $f_1 = (v/2l)$

$$= \frac{340}{2 \times 50 \times 10^{-2}} = 340\text{Hz.}$$

So, the harmonies are

$$f_3 = 3 \times 340 = 1020\text{ Hz}$$

$$f_5 = 5 \times 340 = 1700, f_6 = 6 \times 340 = 2040\text{ Hz}$$

So, the possible frequencies are between 1000Hz and 2000Hz are 1020, 1360, 1700.

**Sol 12: (C)** According to the questions  $f_1$  first overtone of a closed organ pipe

$$P_1 = 3v / 4l = \frac{3 \times V}{4 \times 30}$$

$$f_2 \text{ fundamental frequency of a open organ pipe } P_2 = \frac{V}{2l_2}$$

$$\text{Here given } \frac{3V}{4 \times 30} = \frac{V}{2l_2} \Rightarrow l_2 = 20\text{cm}$$

$\therefore$  Length of the pipe  $P_2$  will be 20 cm.

### Previous Years' Questions

**Sol 1: (B)** Using the formula  $f' = f \left( \frac{v+v_0}{v} \right)$

$$\text{we get, } 5.5 = 5 \left( \frac{v+v_A}{v} \right) \quad \dots (i)$$

$$\text{and } 6.0 = 5 \left( \frac{v+v_B}{v} \right) \quad \dots (ii)$$

Hence,  $v$  = speed of sound

$v_A$  = speed of train A

$v_B$  = speed of train B

Solving Eqs. (i) and (ii), we get

$$\frac{v_B}{v_A} = 2$$

**Sol 2: (A)** Let  $f_0$  = frequency of tuning fork

$$\text{Then, } f_0 = \frac{5}{2l} \sqrt{\frac{9g}{\mu}} \quad (\mu = \text{mass per unit length of wire})$$

$$= \frac{3}{2l} \sqrt{\frac{Mg}{\mu}}$$

Solving this, we get  $M = 25\text{ kg}$

In the first case, frequency corresponds to fifth harmonic while in the second case it corresponds to third harmonic

**Sol 3: (B)** Let  $\Delta l$  be the end correction.

Given that, fundamental tone for a length 0.1 m = first overtone for the length 0.35 cm.

$$\frac{v}{4(0.1 + \Delta l)} = \frac{3v}{4(0.35 + \Delta l)}$$

Solving this equation, we get  $\Delta l = 0.025\text{ m} = 2.5\text{ cm}$

**Sol 4: (D)** The frequency is a characteristic of source. It is independent of the medium.

**Sol 5: (A)** With increase in tension, frequency of vibrating string will increase. Since number of beats are decreasing. Therefore, frequency of vibrating string or third harmonic frequency of closed pipe should be less than the frequency of tuning fork by 4.

$\therefore$  Frequency of tuning fork

= Third harmonic frequency of closed pipe + 4

$$= 3 \left( \frac{v}{4l} \right) + 4 = 3 \left( \frac{340}{4 \times 0.75} \right) + 4 = 344\text{ Hz}$$

**Sol 6: (A)**  $36\text{ km/h} = 36 \times \frac{5}{18} = 10\text{ m/s}$

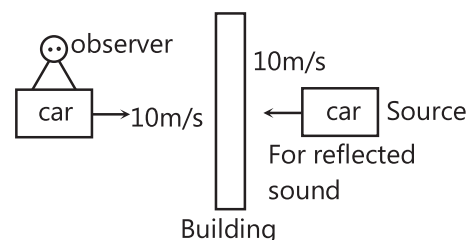

Apparent frequency of sound heard by car driver (observer) reflected from the building will be

$$f' = f \left( \frac{v + v_0}{v - v_s} \right) = 8 \left( \frac{320 + 10}{320 - 10} \right) = 8.5 \text{ kHz}$$

**Sol 7:** Wall will be a node (displacement). Therefore, shortest distance from the wall at which air particles have maximum amplitude of vibration (displacement antinode) should be  $\lambda/4$

$$\text{Here, } \lambda = \frac{v}{f} = \frac{330}{660} = 0.5 \text{ m}$$

$$\therefore \text{Desired distance is } \frac{0.5}{4} = 0.125 \text{ m}$$

**Sol 8:** Fundamental frequency  $f = \frac{v}{2\ell} = \sqrt{\frac{T\ell\mu}{2\ell}}$

$$\text{or } f \propto \sqrt{T}$$

$$\frac{f'}{f} = \sqrt{\frac{w - F}{w}}$$

Here,  $w$  = weight of mass and

$F$  = upthrust

$$f' = f \sqrt{\frac{w - F}{w}}$$

Substituting the values, we have

$$f' = 260 \sqrt{\frac{(50.7)g - (0.0075)(10^3)g}{(50.7)g}} = 240 \text{ Hz}$$

**Sol 9:**  $v_{\text{sound}} = \sqrt{\frac{\gamma RT}{M}}$

$$\frac{v_{\text{H}_2}}{v_{\text{He}}} = \frac{\sqrt{\gamma_{\text{H}_2} / M_{\text{H}_2}}}{\sqrt{\gamma_{\text{He}} / M_{\text{He}}}} = \frac{\sqrt{(7/5)/2}}{\sqrt{(5/3)/4}} = \frac{42}{25}$$

**Sol 10:**

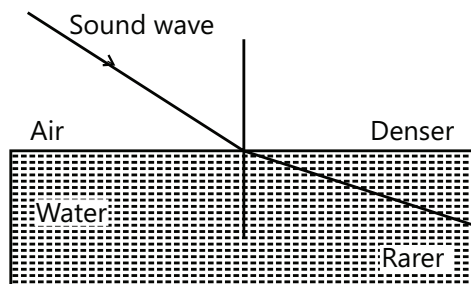

For sound wave water is rarer medium because speed of sound wave in water is more. When a wave travels

from a denser medium to rarer medium it refracts away from the normal

**Sol 11:** For reflected wave an image of source  $S'$  can assumed as shown. Since, both  $S$  and  $S'$  are approaching towards observer, no beats will be heard

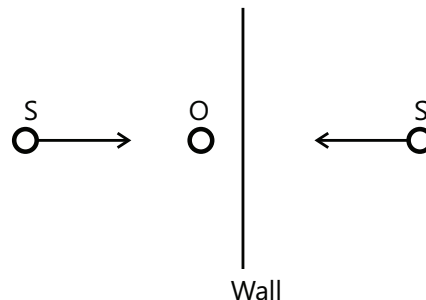

**Sol 12: (B)**

$$n = \frac{1}{4x} \sqrt{\frac{\gamma RT}{M}} \Rightarrow xn = \frac{1}{4} \sqrt{\frac{\gamma RT}{M}}$$

$$\Rightarrow x \propto \sqrt{T}$$

**Sol 13: (B)** Motor cycle,  $u = 0$ ,  $a = 2 \text{ m/s}^2$

Observer is in motion and source is at rest.

$$\Rightarrow n' = n \frac{v - v_0}{v + v_s} \Rightarrow \frac{94}{100} n = n \frac{330 - v_0}{330} \Rightarrow 330 - v_0$$

$$= \frac{330 \times 94}{100}$$

$$\Rightarrow v_0 = 330 - \frac{94 \times 33}{10} = \frac{33 \times 6}{10} \text{ m/s}$$

$$s = \frac{v^2 - u^2}{2a} = \frac{9 \times 33 \times 33}{100} = \frac{9 \times 1089}{100} \approx 98 \text{ m}$$

**Sol 14: (C)** Maximum number of beats =  $v + 1 - (v - 1) = 2$

**Sol 15: (A)**  $f_0 = \frac{v}{2\ell}$ ,  $f_c = \frac{v}{2\ell}$

**Sol 16: (A)**  $P + x = P_0$

$$P = (76 - x)$$

$$8 \times A \times 76 = (76 - x) \times A \times (54 - x)$$

$$x = 38$$

$$\text{Length of air column} = 54 - 38 = 16 \text{ cm.}$$

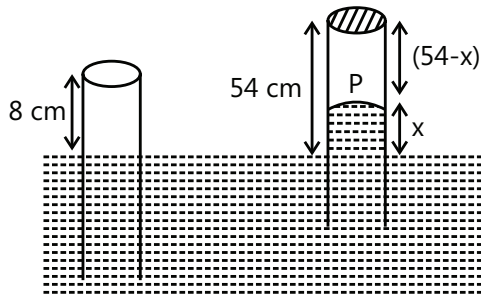

**Sol 17: (B)**

$$f_{\text{before crossing}} = f_0 \left( \frac{c}{c - v_s} \right) = 1000 \left( \frac{320}{320 - 20} \right)$$

$$f_{\text{after crossing}} = f_0 \left( \frac{c}{c + v_s} \right) = 1000 \left( \frac{320}{320 + 20} \right)$$

$$\Delta f = f_0 \left( \frac{2cv_s}{c^2 - v_s^2} \right)$$

$$\frac{\Delta f}{f} \times 100\% = \frac{2 \times 320 \times 20}{300 \times 340} \times 100 = 12.54\% \approx 12\%$$

**Sol 18: (C)** Open organ pipe

$$f = \frac{v}{2\ell}$$

For closed organ pipe

$$f' = \frac{v}{4 \left( \frac{\ell}{2} \right)} = \frac{v}{2\ell} = f$$

## JEE Advanced/Boards

### Exercise 1

**Sol 1:**  $f = 250 \text{ Hz}$   $v = \sqrt{\frac{B}{\rho}} = 20 \text{ ms}^{-1} \text{A} = 10^{-8} \text{m}$

$$\rho = 1 \text{ kg/m}^3$$

$$B = 400 \text{ N/m}^2$$

$$p_0 = \frac{B\omega S_0}{v} = \frac{400 \times 2\pi \times 250 \times 10^{-8}}{20}$$

$$p_0 = 3.14 \times 10^{-4} \text{ N/m}^2$$

$$I = \frac{p_0^2}{2\rho v} = 2.467 \times 10^{-9} \text{ W/m}^2$$

$$\text{Intensity} = 2.467 \times 10^{-9} \text{ W/m}^2$$

**Sol 2:**  $v = \sqrt{\frac{\gamma RT}{M}}$

$$\sqrt{\frac{RT}{M}} = \sqrt{\frac{C}{\sqrt{3}}}$$

$$\gamma = 1 + \frac{2}{6} = \frac{4}{3}$$

$$v = \sqrt{\gamma} \times \frac{C}{\sqrt{3}} = \sqrt{\frac{4}{3}} \times \frac{C}{\sqrt{3}}$$

$$v = \frac{2}{3} C$$

**Sol 3:** For linear source, Intensity  $\propto \frac{1}{R}$

$$A \propto \frac{1}{R^{1/2}}$$

$\therefore$  At 10R

$$\text{Loudness} = 10 \log \frac{I/10}{I_0} = 40 \text{ dB} - 10 \text{ dB}$$

$$\text{Loudness} = 30 \text{ dB}$$

$$\text{Amplitude} = \frac{0.01}{\sqrt{10}} \text{ cm} = 10 \sqrt{10} \mu\text{m}$$

...(i)

**Sol 4:**  $l' = 4l$

$$\text{Loudness} = 10 \log \frac{4I}{I_0} = 10(\log 4 + L_0)$$

$$= 20 \log 2 + L_0 = 6.010 + L_0$$

$$= 6.010 + L_0 = L_0 + 6.01 \text{ dB}$$

$$n = 6.01 \text{ dB}$$

**Sol 5:**  $I = I_1 + I_2 + 2\sqrt{I_1 I_2} \cos\phi$

Here  $I_1 = I_2$

$$I = 2I_1(1 + \cos\phi)$$

$$I_0 = 4I_1$$

$$I_0/2 = 2I_1 = 2I_1(1 + \cos\phi)$$

$$\cos\phi = 0 \Rightarrow \phi = \frac{\pi}{2}$$

$$\Rightarrow \phi = 2\pi \frac{(2\Delta x)}{\lambda}$$

$$\Rightarrow \Delta x = \frac{\frac{\pi}{2} \times \lambda}{2\pi \times 2} = \frac{\lambda}{8}$$

**Sol 6:**  $\frac{V_p}{V_s} = 2$

$$\frac{3}{4l_p} V_p = \frac{3}{2l_p} V_s$$

$$\Rightarrow \frac{l_p}{l_s} = \frac{V_p}{2V_s} = 1$$

$$\Rightarrow \lambda_p : \lambda_s = 1 : 1$$

**Sol 7:**  $500 = \frac{v_A}{\lambda_0}$

Closed pipe:  $\lambda_0 = \frac{330}{500} = 2\lambda_1$

$$\lambda_1 = \frac{330}{1000} \text{ m} = 0.33 \text{ m}$$

$$\lambda_1 = 0.33 \text{ m}$$

Open pipe:  $4\lambda_2 = \frac{264}{500}$

$$\lambda_2 = 0.132 \text{ m}$$

**Sol 8:**  $f_A = 350 \text{ Hz}$

$$|f_A - f_B| = 5 \text{ Hz}$$

$$|f_B - f_C| = 4 \text{ Hz}$$

After waxing

$$|f_A^1 - f_B| = 2 \text{ Hz}$$

$$|f_A^1 - f_C| = 6 \text{ Hz}$$

$f_A > f_B$  initially as on waxing  $f_A$  decreases.

$$f_A - f_B = 5 \text{ Hz} \Rightarrow f_B = 345 \text{ Hz}$$

**Case-I :**  $F_B > F_C$   $F_B - F_C = 4 \text{ Hz} \Rightarrow f_C = 341 \text{ Hz}$

$$f_A^1 = 347 \text{ Hz or } 343 \text{ Hz}$$

$$f_C = 341 \text{ Hz}$$

$$f_A^1 = 347 \text{ Hz}$$

$$f_B = 345 \text{ Hz}$$

$$f_C = 341 \text{ Hz}$$

**Case-II :**  $f_C > f_B$

$$f_C = 349 \text{ Hz}$$

$$f_A^1 = 343 \text{ Hz}$$

$$f_B = 345 \text{ Hz}$$

**Sol 9:**  $f_B = 480 \text{ Hz}$

$|f_B - f_A|$  decreases on waxing

$$\therefore f_A > f_B$$

$$f_A = 485 \text{ Hz}$$

**Sol 10:**

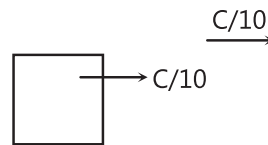

$$f_w = \frac{(C + C/10)}{(C + C/10) - C/10} \times f_0$$

$$f_w = \frac{11}{10} f_0$$

$$f_d = f_w \times \frac{\left(C - \frac{C}{10}\right) + \frac{C}{10}}{\left(C - \frac{C}{10}\right)}$$

$$= \frac{10}{9} f_w$$

$$= \frac{10}{9} \times \frac{11}{10} f_0$$

$$\Rightarrow f_d = \frac{11}{9} f_0$$

**Sol 11:**  $f_a = \frac{C+v}{C} f$

$$f_r = \frac{C-v}{C} f$$

$$\Rightarrow f = \frac{f_a + f_r}{2}$$

**Sol 12:**  $f \left( \frac{C+u}{C} - \left( \frac{C-u}{C} \right) \right) = 10$

$$\frac{2fu}{C} = 10$$

$$u = \frac{5C}{f} \Rightarrow u = \frac{5 \times 340}{680}$$

$$\Rightarrow u = 2.5 \text{ ms}^{-1}$$

## Exercise 2

### Single Correct Choice Type

**Sol 1: (B)** Let the length of the resonating column will be = 1

Here  $V = 320 \text{ m/s}$

Then the two successive resonance frequencies are

$$\frac{(n+1)v}{4l} \text{ and } \frac{nv}{4l}$$

$$\text{Here given } \frac{(n+1)v}{4l} = 2592; \lambda = \frac{nv}{4l} = 1944$$

$$\Rightarrow \frac{(n+1)v}{4l} - \frac{nv}{4l} = 2592 - 1944 \\ = 548 \text{ cm} = 25 \text{ cm.}$$

**Sol 2: (A)** Let, the piston resonates at length  $l_1$  and  $l_2$   
Here,  $l = 32 \text{ cm}$ ;  $v = ?$ ;  $n = 512 \text{ Hz}$

$$\text{Now } \Rightarrow 512 = v / \lambda \Rightarrow v = 512 \times 0.64 = 328 \text{ m/s}$$

**Sol 3: (C)** We know that the frequency =  $f$ ,  $T$  = temperatures

$$f \propto \sqrt{T}$$

$$\text{So } \frac{f_1}{f_2} = \frac{\sqrt{T_1}}{\sqrt{T_2}} ; \Rightarrow \frac{293}{f_2} = \frac{\sqrt{293}}{\sqrt{295}}$$

$$\Rightarrow f_2 = \frac{293 \times \sqrt{295}}{\sqrt{293}} = 294 \text{ Hz}$$

**Sol 4: (A)** A tuning fork produces 4 beats with a known tuning fork whose frequency = 256 Hz

So the frequency of unknown tuning fork = either  $256 - 4 = 252$  or  $256 + 4 = 260 \text{ Hz}$

Now as the first one is load its mass/unit length increases. So, its frequency decreases.

As it produces 6 beats now original frequency must be 252 Hz.

260 Hz is not possible as on decreasing the frequency the beats decreases which is not allowed here.

**Sol 5: (D)**

Group I	Group II
Given $V = 350$	$V = 350$
$\lambda_1 = 32 \text{ cm} = 32 \times 10^{-2} \text{ m}$	$\lambda_2 = 32.2 \text{ cm} = 32.2 \times 10^{-2} \text{ m}$
So $n_2 = 350 / 32 \times 10^{-2} = 1093 \text{ Hz}$	$n_2 = 350 / 32.2 \times 10^{-2} = 1086 \text{ Hz}$

So beat frequency =  $1093 - 1086 = 7 \text{ Hz}$ .

**Sol 6: (A)** Here given  $f_s = 16 \times 10^3 \text{ Hz}$

Apparent frequency  $f' = 20 \times 10^3 \text{ Hz}$  (greater than that value)

Let the velocity of the observer =  $v_0$

Given  $v_s = 0$ . So,

$$20 \times 10 = \left( \frac{330 + v_0}{330 + 0} \right) \times 16 \times 10^3$$

$$\Rightarrow v_0 = \frac{20 \times 330 - 16 \times 330}{4} = \frac{330}{4} \text{ m/s} = 297 \text{ km/h}$$

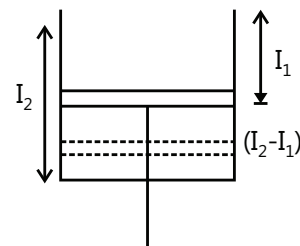

**Assertion Reasoning Type**

**Sol 7: (D)** Closed end is displacement node. So, it must be pressure antinode.

**Sol 8: (A)** Statement-II explains statement-I

## Previous Years' Questions

**Sol 1: (A)** In one second number of maximas is called the beat frequency.

$$\text{Hence, } f_b = f_1 - f_2 = \frac{100\pi}{2\pi} - \frac{92\pi}{2\pi} = 4 \text{ Hz}$$

**Sol 2: (A)** Speed of wave  $v = \frac{\omega}{k}$

$$\text{or } v = \frac{100\pi}{0.5\pi} \text{ or } \frac{92\pi}{0.46\pi} = 200 \text{ m/s}$$

**Sol 3: (C)** At  $x = 0$ ,  $y = y_1 + y_2 = 2A \cos 96\pi t \cos 4\pi t$

Frequency of  $\cos(96\pi t)$  function is 45 Hz and that of  $\cos(4\pi t)$  function is 2 Hz.

In one second,  $\cos$  function becomes zero at  $2f$  times, where  $f$  is the frequency. Therefore, first function will become zero at 96 times and the second at 4 times. But second will not overlap with first. Hence, net  $y$  will become zero 100 times in 1 s.

**Sol 4: (B)**  $v_{SA} = 340 + 20 = 360 \text{ m/s}$

$$v_{SB} = 340 - 30 = 310 \text{ m/s}$$

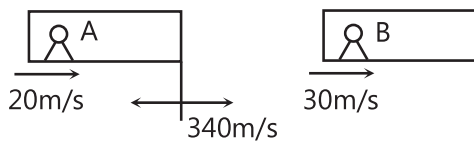

**Sol 5: (A)** For the passengers in train A. There is no relative motion between source and observer, as both are moving with velocity 20 m/s. Therefore, there is no change in observed frequencies and correspondingly there is no change in their intensities.

**Sol 6: (A)** For the passengers in train B, observer is receding with velocity 30 m/s and source is approaching with velocity 20 m/s.

$$f'_1 = 800 \left( \frac{340 - 30}{340 - 20} \right) = 775 \text{ Hz}$$

$$\text{and } f'_2 = 1120 \left( \frac{340 - 30}{340 - 20} \right) = 1085 \text{ Hz}$$

$$\therefore \text{Spread of frequency} = f'_2 - f'_1 = 310 \text{ Hz}$$

**Sol 7: (A, B, D)** For closed pipe,  $f = n \left( \frac{v}{4\ell} \right)$ ;  $n = 1, 3, 5 \dots$

$$\text{For } n = 1, f_1 = \frac{v}{4\ell} = \frac{320}{4 \times 1} = 80 \text{ Hz}$$

$$\text{For } n = 3, f_3 = 3f_1 = 240 \text{ Hz}$$

$$\text{For } n = 5, f_5 = 5f_1 = 400 \text{ Hz}$$

**Sol 8: (A, B, C)** Moving plane is like a moving observer. Therefore, number of waves encountered by moving plane.

$$f_1 = f \left( \frac{v + v_0}{v} \right) = f \left( \frac{c + v}{c} \right)$$

Frequency of reflected wave,

$$f_2 = f_1 \left( \frac{v}{v - v_s} \right) = f \left( \frac{c + v}{c - v} \right)$$

Wavelength of reflected wave

$$\lambda_2 = \frac{v}{f_2} = \frac{c}{f_2} = \frac{c}{f} \left( \frac{c - v}{c + v} \right)$$

**Sol 9:** Frequency heard by the observer due to  $S'$  (reflected wave)

$$f' = f \left( \frac{v + v_0}{v - v_s} \right)$$

$$= 256 \left( \frac{330 + 5}{330 - 5} \right) = 263.87 \text{ Hz}$$

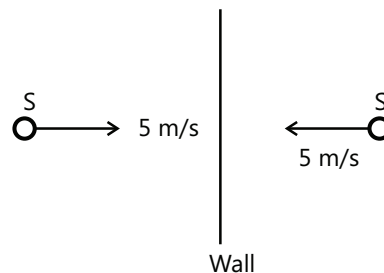

$$\therefore \text{Beat frequency } f_b = f' - f = 7.87 \text{ Hz}$$

**Sol 10:** Angular frequency of detector

$$\omega = 2\pi f = 2\pi \left( \frac{5}{\pi} \right) = 10 \text{ rad/s}$$

Since, angular frequency of source of sound and of detector are equal, their time periods will also be equal.

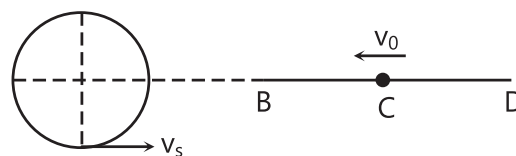

Maximum frequency will be heard in the position shown in figure. Since, the detector is far away from the source, we can use,

$$f_{\max} = f \left( \frac{v + v_0}{v - v_s} \right)$$

Here,  $v$  = speed of sound = 340 m/s

(given)  $v_s = R\omega = 30 \text{ m/s}$

$$v_0 = \omega A = 60 \text{ m/s}$$

$$\therefore f_{\max} = 340 \frac{(340 + 60)}{(340 - 30)} = 438.7 \text{ Hz}$$

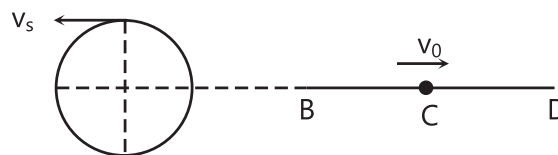

Minimum frequency will be heard in the condition shown in figure. The minimum frequency will be:

$$f_{\min} = f \left( \frac{v - v_0}{v + v_s} \right) = 340 \frac{(340 - 60)}{(340 + 30)} = 257.3 \text{ Hz}$$

**Sol 11:** Speed of sound  $v = 340$  m/s

Let  $\lambda_0$  be the length of air column corresponding to the fundamental frequency. Then,

$$\frac{v}{4\ell_0} = 212.5$$

$$\text{or } \lambda_0 = \frac{v}{4(212.5)} = \frac{340}{4(212.5)} = 0.4 \text{ m}$$

In closed pipe only odd harmonics are obtained. Now let  $\lambda_1, \lambda_2, \lambda_3, \lambda_4,$  etc., be the lengths corresponding to the 3<sup>rd</sup> harmonic, 4<sup>th</sup> harmonic, 7<sup>th</sup> harmonic etc. Then

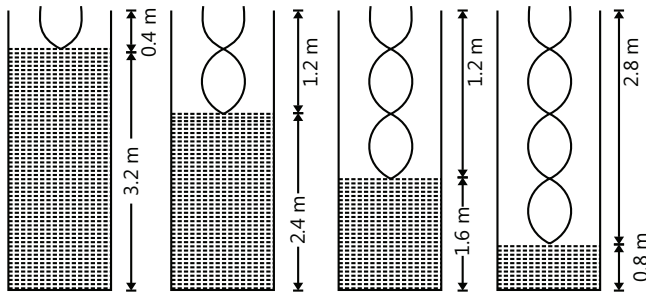

$$3 \left( \frac{v}{4\ell_1} \right) = 212.5 \Rightarrow \lambda_1 = 1.2 \text{ m}$$

$$5 \left( \frac{v}{4\ell_2} \right) = 212.5 \Rightarrow \lambda_2 = 2.0 \text{ m}$$

$$\text{and } 7 \left( \frac{v}{4\ell_3} \right) = 212.5 \Rightarrow \lambda_3 = 2.8 \text{ m}$$

$$9 \left( \frac{v}{4\ell_4} \right) = 212.5 \Rightarrow \ell_4 = 3.6 \text{ m}$$

or heights of water level are  $(3.6 - 0.4)$  m,  $(3.6 - 1.2)$  m,  $(3.6 - 2.0)$  m and  $(3.6 - 2.8)$  m.

$\therefore$  Heights of water level are 3.2 m, 2.4 m, 1.6 m and 0.8 m

Let  $A$  and  $a$  be the area of cross-sections of the pipe and hole respectively. Then

$$A = \pi(2 \times 10^{-2})^2 = 1.26 \times 10^{-3} \text{ m}^2$$

$$\text{and } a = \pi(10^{-3})^2 = 3.14 \times 10^{-6} \text{ m}^2$$

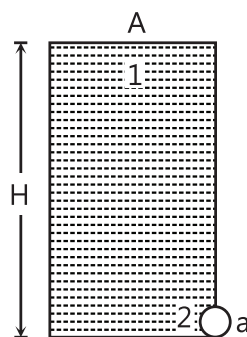

$$\text{Velocity of efflux, } v = \sqrt{2gH}$$

Continuity equation at 1 and 2 gives

$$a \sqrt{2gH} = A \left( \frac{-dH}{dt} \right)$$

$\therefore$  Rate of fall of water level in the pipe,

$$\left( \frac{-dH}{dt} \right) = \frac{a}{A} \sqrt{2gH}$$

Substituting the values, we get

$$\frac{-dH}{dt} = \frac{3.14 \times 10^{-6}}{1.26 \times 10^{-3}} \sqrt{2 \times 10 \times H}$$

$$\text{or } - \frac{dH}{dt} = (1.11 \times 10^{-2}) \sqrt{H}$$

Between first two resonances, the water level falls from 3.2 m to 2.4 m.

$$\therefore \frac{dH}{\sqrt{H}} = - (1.11 \times 10^{-2}) dt$$

$$\text{or } \int_{3.2}^{2.4} \frac{dH}{\sqrt{H}} = - (1.11 \times 10^{-2}) \int_0^1 dt$$

$$\text{or } 2[\sqrt{2.4} - \sqrt{3.2}] = - (1.11 \times 10^{-2})t$$

$$\text{or } t = 43 \text{ s}$$

**Note:** Rate of fall of level at a height  $h$  is

$$\left( \frac{-dh}{dt} \right) = \frac{a}{A} \sqrt{2gh} \propto \sqrt{h}$$

i.e., rate decreases as the height of water (or any other liquid) decreases in the tank. That is why, the time required to empty the first half of the tank is less than the time required to empty the rest half of the tank.

**Sol 12:** From the relation,  $f' = f \left( \frac{v}{v \pm v_s} \right)$ ,

$$\text{we have } 2.2 = f \left[ \frac{300}{300 - v_T} \right] \quad \dots (i)$$

$$\text{and } 1.8 = f \left[ \frac{300}{300 + v_T} \right] \quad \dots (ii)$$

Here,  $v_T = v_s =$  velocity of source/train

Solving Eqs. (i) and (ii), we get

$$v_T = 30 \text{ m/s}$$



**Sol 13:** Firstly, car will be treated as an observer which is approaching the source. Then, it will be treated as a source, which is moving in the direction of sound.



$$\text{Hence, } f_1 = f_0 \left( \frac{v + v_1}{v - v_1} \right)$$

$$f_2 = f_0 \left( \frac{v + v_2}{v - v_2} \right)$$

$$\therefore f_1 - f_2 = \left( \frac{1.2}{100} \right) f_0 = f_0 \left[ \frac{v + v_1}{v - v_1} - \frac{v + v_2}{v - v_2} \right]$$

$$\text{or } \left( \frac{1.2}{100} \right) f_0 = \frac{2v(v_1 - v_2)}{(v - v_1)(v - v_2)} f_0$$

As  $v_1$  and  $v_2$  are very very less than  $v$ .

We can write,  $(v - v_1)$  or  $(v - v_2) \approx v$

$$\therefore \left( \frac{1.2}{100} \right) f_0 = \frac{2(v_1 - v_2)}{v} f_0$$

$$\text{or } (v_1 - v_2) = \frac{v \times 1.2}{200} = \frac{330 \times 1.2}{200} = 1.98 \text{ ms}^{-1} \\ = 7.128 \text{ kmh}^{-1}$$

$\therefore$  The nearest integer is 7

$$\text{Sol 14: (A) } f = \frac{320}{320 - 10} \times 8 \times 10^3 \times \frac{320 + 10}{320} = 8.5 \text{ kHz}$$

**Sol 15: (B, D)** At the open end, the phase of a pressure wave changes by  $\pi$  radian due to reflection. At the closed end, there is no change in the phase of a pressure wave due to reflection.

$$\text{Sol 16: (D) } \ell = \frac{1}{4v} \sqrt{\frac{\gamma RT}{M}}$$

Calculations for  $\frac{1}{4v} \sqrt{\frac{\gamma RT}{M}}$  for gases mentioned in

options A, B, C and D, work out to be 0.459 m, 0.363 m, 0.340 m & 0.348 m respectively. As  $\ell = (0.350 \pm 0.005)$  m; Hence correct option is D.

**Sol 17: (A, B, D)** Frequency of M received by car

$$f_1 = 118 \left( \frac{V + V_0 \cos \theta}{V} \right)$$

$$f_2 = 121 \left( \frac{V + V_0 \cos \theta}{V} \right)$$

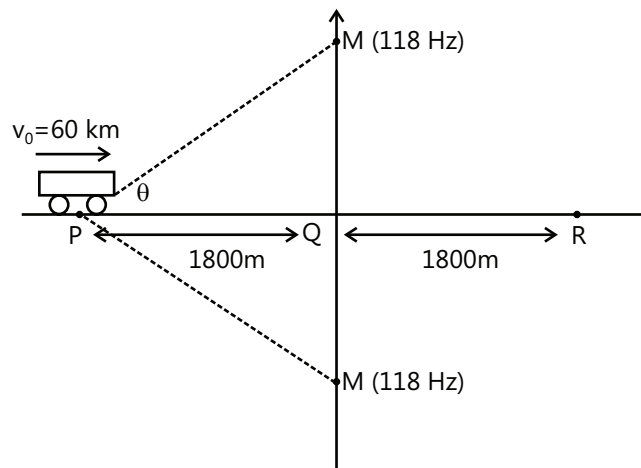

$$\text{No. of beats } n = \Delta f = f_2 - f_1$$

$$n = 3 \left( \frac{V + V_0 \cos \theta}{V} \right)$$

$$n = 3 \left( 1 + \frac{V_0}{V} \cos \theta \right)$$

As  $\theta \uparrow$ ,  $\cos \theta \downarrow$ ,  $n \downarrow$

$$\text{Rate of change of beat frequency } \frac{dn}{d\theta} = 3 \left[ \frac{V_0}{V} (-\sin \theta) \right]$$

$$\frac{dn}{d\theta} \text{ is maximum when } \sin \theta = 1; \theta = 90^\circ$$

i.e. car is at point Q.

$$v_P = 3 \left( 1 + \frac{V_0}{V} \cos \theta \right)$$

$$v_R = 3 \left( 1 - \frac{V_0}{V} \cos \theta \right)$$

At Q

$$\text{No. of beats } v_Q = 121 - 118 = 3$$

$$v_Q = \frac{v_P + v_R}{2}$$

**Sol 18: (A, D)** Larger the length of air column, feebler is the intensity.

**Sol 19: (B)**

$$\frac{v_s}{4L_p} = \frac{2\sqrt{\frac{T}{\mu}}}{2\ell_s}$$

$$\mu\ell_s = 10\text{ gm}$$

**Sol 20: (B)**

$$\frac{V}{4(\ell + e)} = f$$

$$\Rightarrow \ell + e = \frac{V}{4f} \Rightarrow \ell = \frac{V}{4f} - e$$

Here  $e = (0.6)r = (0.6)(2) = 1.2\text{ cm}$ 

$$\text{So } \ell = \frac{336 \times 10^2}{4 \times 512} - 1.2 = 15.2\text{ cm}$$

**Sol 21: (A, B)** If wind blows from source to observer

$$f_2 = f_1 \left( \frac{V + w + u}{V + w - u} \right)$$

When wind blows from observer towards source

$$f_2 = f_1 \left( \frac{V - w + u}{V - w - u} \right)$$

In both cases,  $f_2 > f_1$ .**Sol 22:** First and fourth wave interfere destructively. So from the interference of 2nd and 3rd wave only,

$$\Rightarrow I_{\text{net}} = I_0 + I_0 + 2\sqrt{I_0}\sqrt{I_0} \cos\left(\frac{2\pi}{3} - \frac{\pi}{3}\right) = 3I_0$$

$$\Rightarrow n = 3$$