

Class 11

2017-18



# CHEMISTRY

## FOR JEE MAIN & ADVANCED

SECOND  
EDITION



Topic Covered  
Alkanes

Exhaustive Theory ◀  
(Now Revised)

Formula Sheet ◀

9000+ Problems ◀  
based on latest JEE pattern

2500 + 1000 (New) Problems ◀  
of previous 35 years of  
AIEEE (JEE Main) and IIT-JEE (JEE Adv)

5000+ Illustrations and Solved Examples ◀

Detailed Solutions ◀  
of all problems available

Planceess Concepts

Tips & Tricks, Facts, Notes, Misconceptions,  
Key Take Aways, Problem Solving Tactics

Planceessential

Questions recommended for revision

# 10. ALKANES

## 1. INTRODUCTION

### 1.1 Classification of Hydrocarbon

Hydrocarbon – Molecule with only C – C and C – H bonds

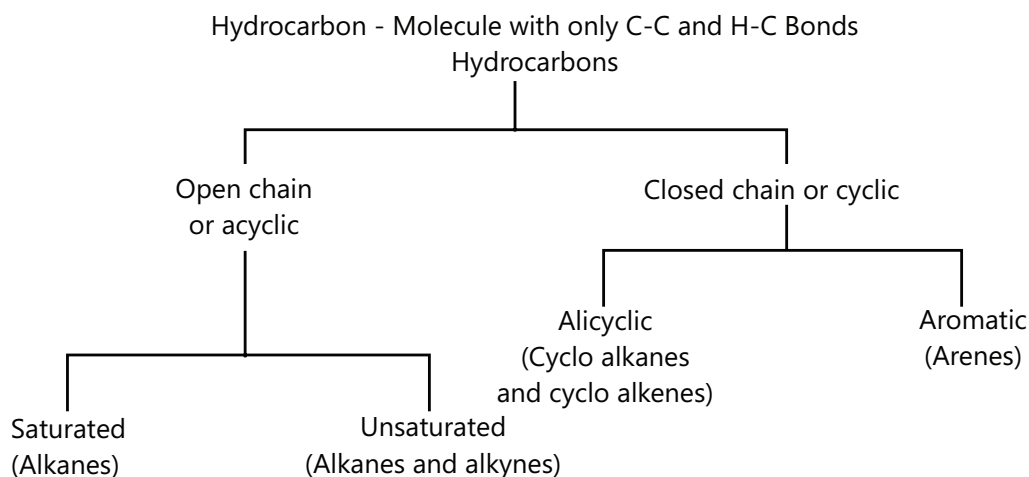

**Flowchart 10.1:** Flowchart on classification of hydrocarbon

Alkane – Hydrocarbons with only single bonds.

Alkene – Hydrocarbons with one or more double bonds.

Alkyne – Hydrocarbons with one or more triple bonds.

### 1.2 Saturated Hydrocarbons or Alkanes or Paraffin's

- Alkanes have general formula  $C_nH_{2n+2}$  where  $n$  ranges from 1 to  $n$ .  
E.g.,  $CH_4$ ,  $C_2H_6$ ,  $C_3H_8$   
Methane      Ethane      Propane
- Alkanes are not very reactive by nature, and are hence also called paraffins. (latin: Parum = little, affins = affinity)
- Each carbon atom is  $sp^3$  hybridized and its four bonding orbitals are directed towards the four corners of a regular tetrahedron at an angle of  $109^\circ28'$  or  $109.5^\circ$ .  
The tetrahedral of alkane is described below, e.g.,  $C_2H_6$ .

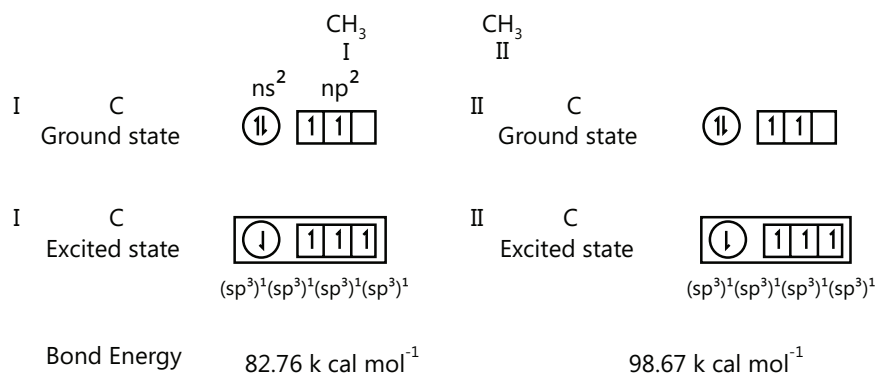
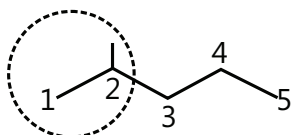

**Illustration 1:** The compound that has one isopropyl group is:

- (a) 2-Methyl pentane                      (b) 2, 2, 3, 3-Tetramethyl pentane  
 (c) 2, 2-Dimethyl pentane              (d) 2, 2, 3-Tetramethyl pentane

(IIT-JEE, 1989)

**Sol:** 2-methyl pentane contains one isopropyl group.



One isopropyl group  
2-Methyl pentane

- (a) 2,2,3,3-Tetramethyl pentane contains two butyl group

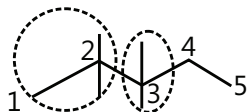

Two butyl groups  
2,2,3,3-Tetramethyl pentane

- (b) 2, 2-dimethyl pentane contains one t-Butyl group.

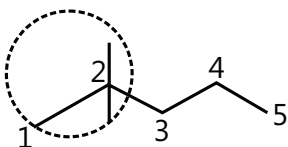

One t-butyl group  
2,2-Dimethyl pentane

- (c) 2,2,3-Trimethyl pentane contains one isopropyl group and one t-butyl group

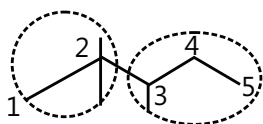

One t-butyl group  
one isobutyl group  
2,2,3- Trimethyl pentane

### 1.3 Nomenclature and Structure of Alkanes

Sl. No.	$C_n H_{2n+2}$	Structure
1	$CH_4$	$\begin{array}{c} H \\   \\ H - C - H \\   \\ H \end{array}$
2	$C_2H_6$	$H_3C - CH_3$
3	$C_3H_8$	$H_3C - \text{CH}_2 - CH_3$
4	$C_4H_{10}$	$H_3C - CH_2 - CH_2 - CH_3$ $\begin{array}{c} H_3C \\   \\ H_3C - C - CH_3 \\   \\ H_3C \end{array}$
5	$C_5H_{12}$	$H_3C - CH_2 - CH_2 - CH_2 - CH_3$ $H_3C - \begin{array}{c} CH_3 \\   \\ CH_2 \\   \\ CH_2 \\   \\ CH_3 \end{array} - CH_3$ $\begin{array}{c} H_3C & & CH_3 \\ & \diagdown & / \\ & C & \\ & / & \diagdown \\ H_3C & & CH_3 \end{array}$ <p style="text-align: center;"> <span style="margin-right: 100px;">Straight chain alkanes "normal (n)"</span> <span>Branched alkanes</span> </p>

Nomenclature for Branched Alkyl Groups			
<u>Iso</u> $\begin{array}{c} H \\   \\ \text{---}C - CH_3 \\   \\ CH_3 \\   \\ \text{---}Pr \end{array}$ <p>Isopropyl</p>	<u>Neo</u> $\begin{array}{c} CH_3 \\   \\ \text{---}C - C - CH_3 \\   \\ H_2 \\   \\ CH_3 \end{array}$ <p>Neopentyl</p>	<u>Seco</u> $\begin{array}{c} H \\   \\ \text{---}C - C - CH_3 \\   \\ CH_3 \\   \\ \text{---}^sBu \end{array}$ <p>Sec-butyl s-butyl</p>	<u>Tert</u> $\begin{array}{c} CH_3 \\   \\ \text{---}C - CH_3 \\   \\ CH_3 \\   \\ \text{---}^tBu \end{array}$ <p>Tert-butyl t-butyl</p>
$\begin{array}{c} H_2H \\   \\ \text{---}C - C - CH_3 \\   \\ CH_3 \\   \\ \text{---}Bu \end{array}$ <p>Isobutyl</p>	$\begin{array}{c} CH_3 \\   \\ \text{---}C - C - C - CH_3 \\   \quad   \\ H_2H_2 \quad CH_3 \\   \\ CH_3 \end{array}$ <p>Neohexyl</p>		$\begin{array}{c} CH_3 \\   \\ \text{---}C - C - CH_3 \\   \\ CH_3 \end{array}$ <p>Tert-pentyl t-pentyl</p>

Figure 10.1: Table showing nomenclature for branched alkyl group

<b>H by C - C connectivity</b>	$\begin{array}{c} \text{R} \\   \\ \text{H}-\text{C}-\text{H} \\   \\ \text{H} \end{array}$ Primary hydrogens 1°	$\begin{array}{c} \text{R} \\   \\ \text{R}-\text{C}-\text{H} \\   \\ \text{H} \end{array}$ Secondary hydrogens 2°	$\begin{array}{c} \text{R} \\   \\ \text{R}-\text{C}-\text{R} \\   \\ \text{H} \end{array}$ Tertiary hydrogens 3°	
<b>sp<sup>3</sup> C by C - H connectivity</b>	$\begin{array}{c} \text{H} \\   \\ \text{H}-\text{C}-\text{H} \\   \\ \text{H} \end{array}$ Methane	$\begin{array}{c} \text{H} \\   \\ \text{R}-\text{C}-\text{H} \\   \\ \text{H} \end{array}$ Methyl	$\begin{array}{c} \text{H} \\   \\ \text{R}-\text{C}-\text{R} \\   \\ \text{H} \end{array}$ Methylene	$\begin{array}{c} \text{H} \\   \\ \text{R}-\text{C}-\text{R} \\   \\ \text{H} \end{array}$ Methine
<b>sp<sup>3</sup> C by C - C connectivity</b>	$\begin{array}{c} \text{R} \\   \\ \text{H}-\text{C}-\text{H} \\   \\ \text{H} \end{array}$ Primary carbon 1°	$\begin{array}{c} \text{R} \\   \\ \text{R}-\text{C}-\text{H} \\   \\ \text{H} \end{array}$ Secondary carbon 2°	$\begin{array}{c} \text{R} \\   \\ \text{R}-\text{C}-\text{R} \\   \\ \text{H} \end{array}$ Tertiary carbon 3°	$\begin{array}{c} \text{R} \\   \\ \text{R}-\text{C}-\text{R} \\   \\ \text{R} \end{array}$ Quaternary carbon 4°

**Illustration 2:**

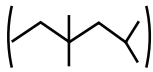
- (a) Write the IUPAC name of the compound (A) whose bond line structure is 
- (b) Write the condensed formula of the compound (A)
- (c) Define and identify all the primary (1°), secondary (2°), tertiary (3°), and quaternary (4°) carbon atoms.
- (d) Identify all the 1°, 2° and 3° H atoms.
- (e) Give the number of H atoms bonded to 1°, 2°, 3° and 4° C atom in an alkane.
- (f) Give the number of C atoms bonded to 1°, 2°, 3° and 4° C atom in an alkane.

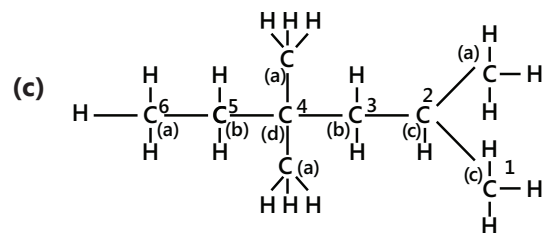
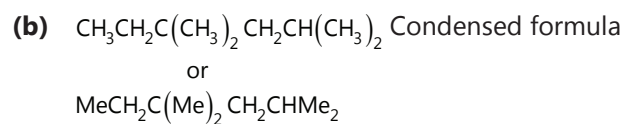
**(JEE MAIN)****Sol:**

$$a = 1^\circ, b = 2^\circ, c = 3^\circ, d = 4^\circ$$

- (d) 1°Carbon is bonded to only one other C, a 2°Carbon is bonded to two other C atoms, a 3°Carbon is bonded to three other C atoms, and a 4°Carbon is bonded to four other C atoms. (The C of  $\text{CH}_4$  is 1°)

- (e)  $1^\circ$  hydrogen atoms are those attached to primary carbon atoms,  $2^\circ$  H atoms to secondary carbon atoms, and  $3^\circ$  H atoms to tertiary carbon atoms;  $4^\circ$  H atoms cannot exist because all four bonds to a quaternary carbon are attached to other C atoms.
- (f) H atoms bonded to  $1^\circ$ ,  $2^\circ$ ,  $3^\circ$  and  $4^\circ$  C atoms are 3, 2, 1, and 0 respectively.
- (g) C atoms bonded to  $1^\circ$ ,  $2^\circ$ ,  $3^\circ$  and  $4^\circ$  C atoms are 1, 2, 3, and 4 respectively.

## 1.4 Isomerism in Alkanes

**Isomers** – Are structures with the same molecular formula but with a different atomic arrangement.

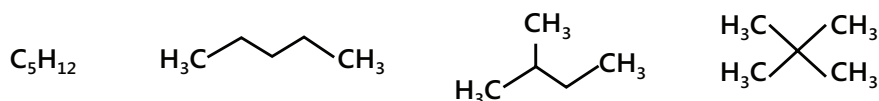

**Constitutional isomers** – Are isomers that differ in atom connectivity.

$C_5H_{12}$  shows three chain isomers:

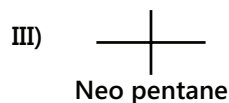
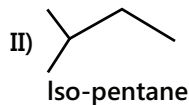
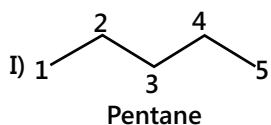

$C_6H_{14}$  shows five chain isomers:

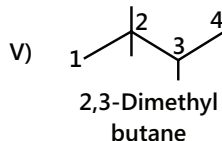
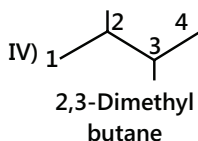
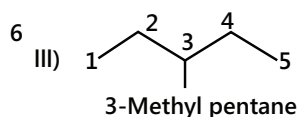
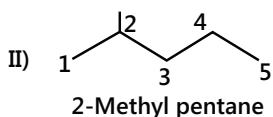
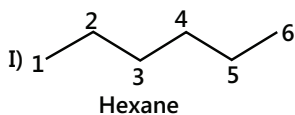

**Conformational Isomers:**

Infinite number of spatial arrangements that a molecule can adopt in space due to rotation about  $\sigma$  bonds are called rotational or conformational isomers. Analysis of energy changes during these rotations is called conformational analysis.

(a) **Conformations of ethane:**

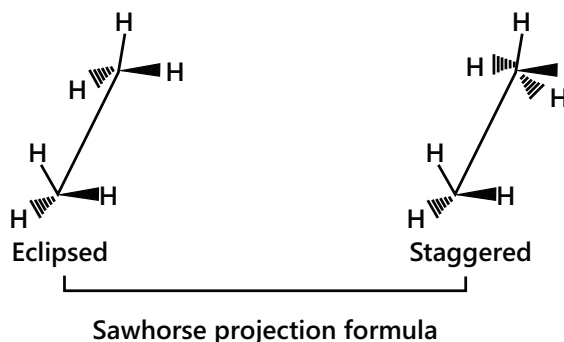

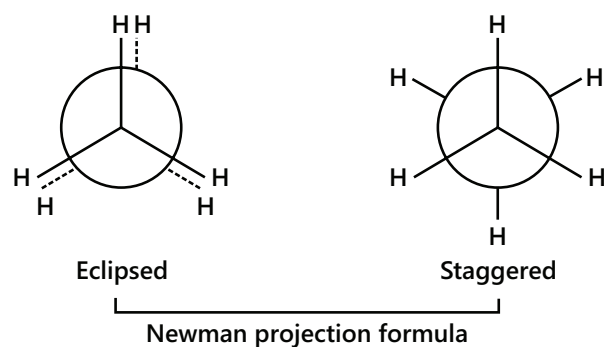

**Figure 10.2:** Conformation of ethane in newman and sawhorse projection formula

**(b) Conformation of butane (Newman projection formula):**

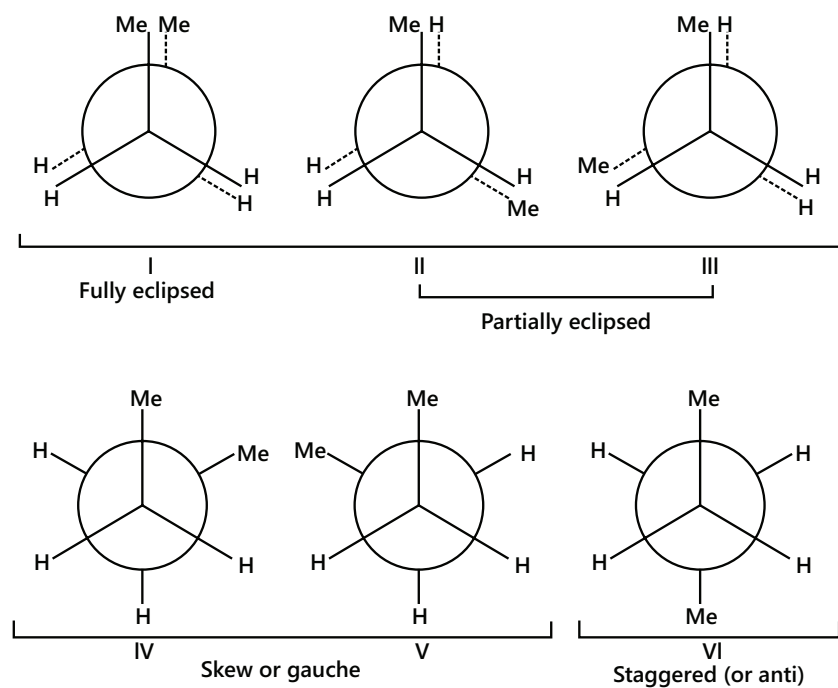

**Figure 10.3:** Conformation of butane in newman projection formula

**Illustration 3:** Write the IUPAC name, bond line structure, and condensed formula for the following alkanes with the greatest number of (Me) groups.

- (a)  $C_7H_{16}$       (b)  $C_8H_{18}$       (c)  $C_{10}H_{22}$       (d)  $C_{11}H_{24}$

**Sol:**

(a) Bond line structure:

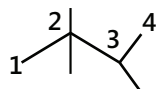

IUPAC name: 2, 2, 3-Trimethyl butane

Condensed formula:  $(CH_3)_3CCH(CH_3)_2$  or  $Me_3CCHMe_2$

(b) Bond line structure:

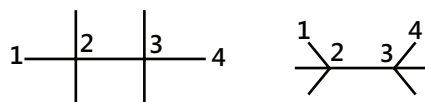

IUPAC name: 2, 2, 3, 3-Tetramethyl butane

Condensed formula:  $(\text{CH}_3)_3\text{C.C}(\text{CH}_3)_3$  or  $\text{Me}_3\text{C.CMe}_3$

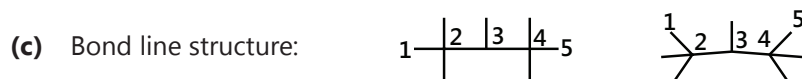

IUPAC name: 2, 2, 3, 4, 4-Pentamethyl pentane

Condensed formula:  $(\text{CH}_3)_3\text{CCH}(\text{CH}_3)\text{C}(\text{CH}_3)_3$  or  $\text{Me}_3\text{C.CH}(\text{Me})\text{CMe}_3$

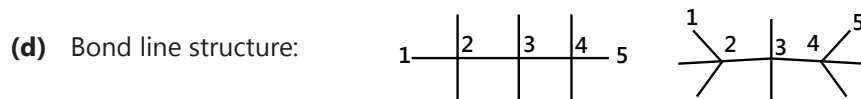

IUPAC name: 2, 2, 3, 3, 4, 4-Hexamethyl pentane

Condensed formula:  $(\text{CH}_3)_3\text{C.C}(\text{CH}_3)_2\text{C}(\text{CH}_3)_3$  or  $\text{Me}_3\text{C.C}(\text{Me})_2\text{CMe}_3$

**Illustration 4:** Which conformers of ethylene chlorohydrin and ethylene glycol is more stable:

The most stable conformer of ethylene chlorohydrin and ethylene glycol is the gauche conformer. The gauche form is more stable due to intra molecular Hydrogen –bonding. In case of ethylene chlorohydrin H-Bonding is formed between the Hydrogen of OH group and Cl and in case of ethylene glycol hydrogen bonding is formed between two OH groups.

**Sol:**

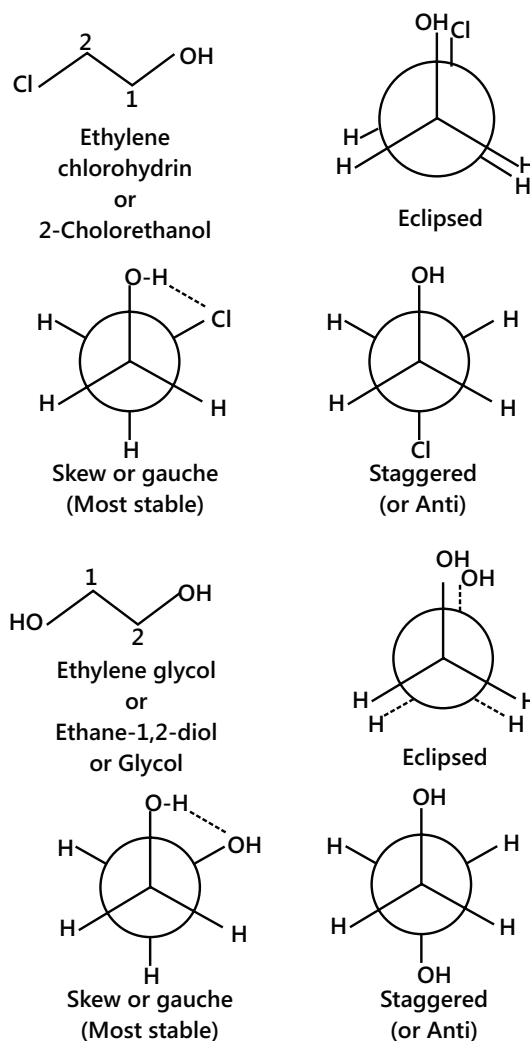



## 2. PREPARATION OF ALKANES

### 2.1 From Unsaturated Hydrocarbons

#### 1. Hydroboration/ 2. Reduction

Hydrogenation or reduction is the process by which hydrogen is added to an unsaturated compound in the presence of a catalyst.

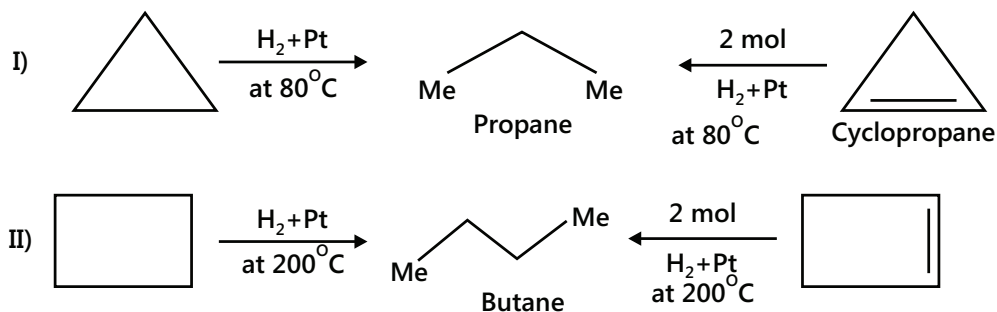

Alkenes and alkynes add one and two molecules of hydrogen, respectively, in the presence of a catalyst, such as finely divided nickel or palladium or platinum at 523–573 K to form alkanes. This reaction is commonly referred to as Sabatier and Senderson's reduction.

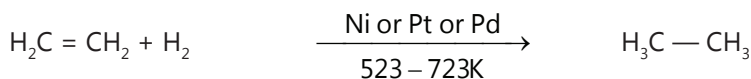

Ethene or (Ethylene) Ethane

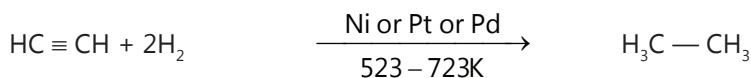

Ethene or (Acetylene) Ethane

Cycloalkane on hydrogenation gives alkane. The reactivity order of cycloalkanes is:

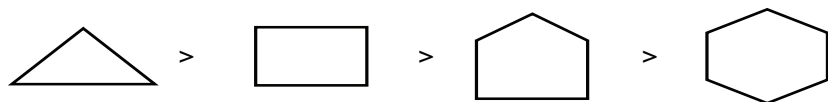

This is due to the angle strain. Greater the angle strain in the ring, less stable and more reactive is the compound. So, cyclopropane is the most reactive and gives propane on hydrogenation at lower temperature, whereas higher cycloalkanes require high temperature.

### 2.2 From Alkyl Halides

#### 2.2.1 Using Grignard Reagent

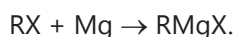

For a given alkyl halide, the degree ease of formation of G.R. is: iodide > bromide > chloride. Similarly, for a halogen atom, the ease of formation of G.R. is greater with a smaller alkyl group than that with bigger alkyl groups. For example,  $\text{CH}_3\text{I} > \text{C}_2\text{H}_5\text{I} > \text{C}_3\text{H}_7\text{I}$

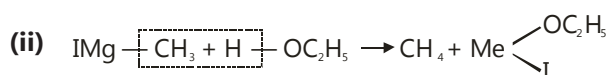
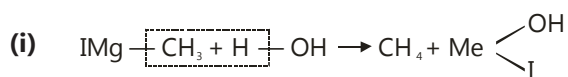

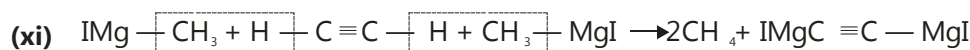
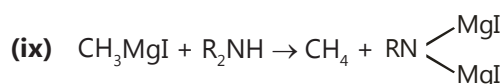
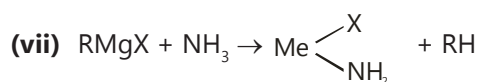
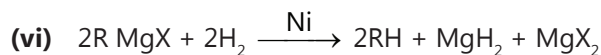
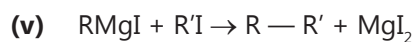
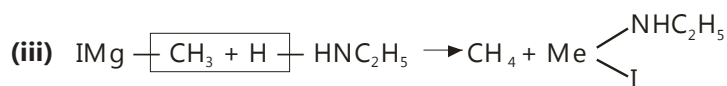
**Illustration 5:****(JEE ADVANCED)**

- (a) 0.21 gm of but-3-yn-2-ol is treated with excess of  $\text{C}_2\text{H}_5\text{MgBr}$  at standard conditions. The volume of gas evolved is:
- (A) 134.4 mL      (B) 146.4 mL      (C) 67.2 mL      (D) 73.2 mL
- (b) 0.46 gm of a compound with molecular mass of 92 gm gave 336 mL of a gas at STP when treated with excess of  $\text{CH}_3\text{MgI}$ . The number of moles of gas evolved or the number of active H atoms in the compound is
- (A) 0.1      (B) 2      (C) 3      (D) 4
- (c) The treatment of  $\text{CH}_3\text{OH}$  with  $\text{CH}_3\text{MgI}$  releases 1.04 mL of a gas at STP. The mass of  $\text{CH}_3\text{OH}$  added is:
- (A) 1.49 mg      (B) 2.98 mg      (C) 3.71 mg      (D) 4047 mg
- (d) The addition of 4.12 mg of an unknown alcohol  $\text{ROH}$ , to  $\text{CH}_3\text{MgI}$  releases 1.56 mL of a gas at STP. The molar mass of alcohol is
- (A) 32 gm mol/L      (B) 46 gm mol/L      (C) 59 gm mol/L      (D) 74 gm mol/L
- (e) The sample of 1.79 mg of a compound of molar mass 90 gm mol/L when treated with  $\text{CH}_3\text{MgI}$  releases 1.34 mol of a gas at STP. The number of moles of active hydrogen in the molecule is:
- (A) 1      (B) 2      (C) 3      (D) 4

**Sol:** At STP condition,Volume of 1 mol of a gas = 22.4 litres (when  $P = 1 \text{ atm}$ ,  $T = 273\text{K}$ ).If  $P = 1 \text{ bar}$  and  $T = 273 \text{ K}$ , then volume = 22.7 litres.Similarly, at standard condition, when  $P = 1 \text{ atm}$  and  $T = 298 \text{ K}$ , then volume = 24.4 litresWhen  $P = 1 \text{ bar}$  and  $T = 298 \text{ K}$ , then volume = 24.7 litres.**(a)** Correct answer is B

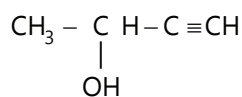

(It contains two active H atoms).

One mole of compound (70 gm) gives 2 mol of  $\text{C}_2\text{H}_6$  gas  
Seventy grams of compound  $\Rightarrow 2 \times 24.4$  litres of  $\text{C}_2\text{H}_6$  gas at standard condition.

$$\therefore 0.21 \text{ gm of the compound} = \frac{2 \times 2.24 \times 0.21}{70} = 0.1464 \text{ litre} = 146.4 \text{ mL}$$

**(b)** Correct option is C

Since 0.46 gm of a compound gives off 336 mL of a gas at STP.

$$\therefore 92 \text{ gm of a compound would give} \Rightarrow \frac{336 \times 92}{0.46} = 67200 \text{ mL} = \frac{67200}{22400} = 3 \text{ mol}$$

Therefore, number of active H atoms = 3.

**(c)** Correct answer is A

$\text{CH}_3\text{OH}$  contains only one active H atom. (Active hydrogen  $-\text{OH}$ )

So, 1 mol of  $\text{CH}_3\text{OH}$  gives 1 mol of  $\text{CH}_4$  gas.

22400 mL of  $\text{CH}_4$  gas is obtained from 32 gm of Methanol. (Molecular mass of  $\text{MeOH}$ –32)

$$\therefore 1.04 \text{ mL of } \text{CH}_4 \text{ gas is obtained} \Rightarrow \frac{32 \times 1.04}{22400} \Rightarrow 0.00148 \text{ g} \Rightarrow 1.49 \text{ mg}$$

**(d)** Correct option is C

Here it is given that 1.56 mL of a gas is obtained from  $4.12 \times 10^{-3}$  gm of ROH.

$$\text{Therefore, 22400 mL of a gas is obtained from } \frac{4.12 \times 10^{-3} \times 22400}{1.56} = 59.15 \text{ gm mol/L}$$

**(e)** Correct option is C

Let 1 mol of a compound gives x mol of a gas.

$$\therefore 90 \text{ gm of a compound would give} = x \times 22400 \text{ mL of gas}$$

$$1.79 \times 10^{-3} \text{ gm of a compound gives} \Rightarrow \frac{x \times 22400 \times 10^{-3}}{90}$$

$$\therefore \frac{x \times 22400 \times 1.79 \times 10^{-3}}{90} = 1.34 \therefore x = 3$$

## 2.2.2 Wurtz reaction

**Wurtz reaction:** The reaction of an Alkyl halide with sodium in dry ether to give a hydrocarbon containing double the number of carbon atoms present in the halide.

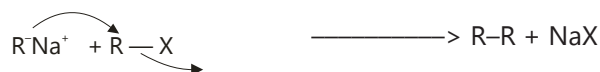
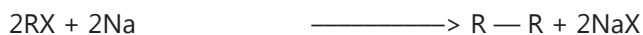

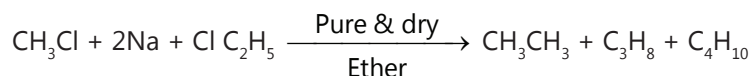
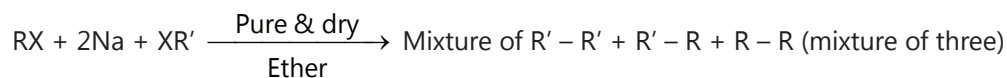
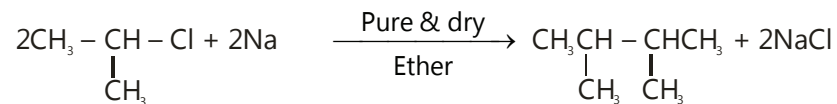
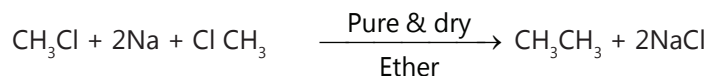
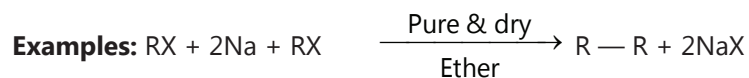

### Fittig reaction

Haloarene reacts with a metallic sodium in the presence of an anhydrous ether to form a Diphenyl which is an aromatic hydrocarbon

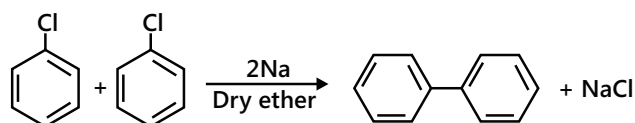

### Wurtz-fittig reaction

The mixture of an alkyl halide gives an alkyl arene when treated with sodium in presence of dry ether

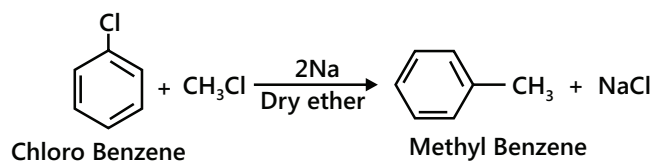

## PLANCESS CONCEPTS

**Exceptions: a. Limitations of the reaction:** If the same RX is used the alkane containing odd number of C atoms or unsymmetrical alkanes cannot be prepared. If different alkyl halides are used, a mixture of alkanes and alkenes is obtained.

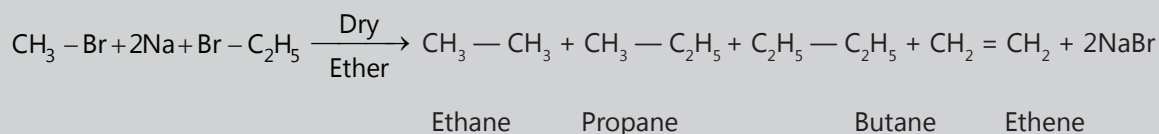
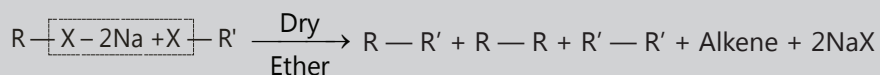

**Saurabh Gupta (JEE 2010, AIR 443)**

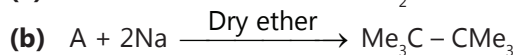
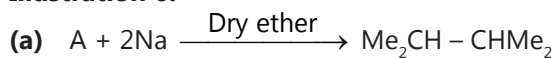
**Illustration 6:**

(c) One mole of  $\text{CH}_3\text{Br}$  and 1 mole of  $\text{C}_2\text{H}_5\text{Br}$  are reacted with 2 mol of sodium metal in dry ether.

The products thus obtained are:

(i) Ethane + 2NaBr

(ii) Ethane + Propane + 2NaBr

(iii) Ethane + Propane + Butane + 2NaBr

(iv) Ethane + Propane + Butane + Ethane + 2NaBr

**Sol:**

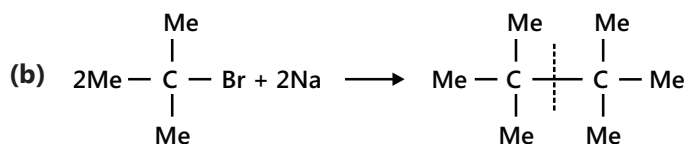
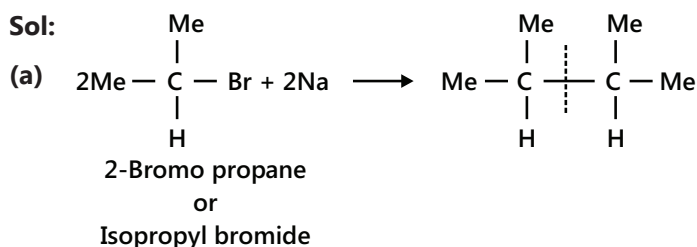

(c) Answer (iv)

Reaction of 2 moles of methyl bromide with sodium produces ethane.

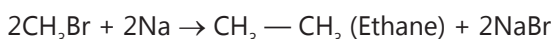

Reaction of 2 moles of ethyl bromide with sodium produces butane

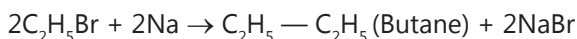

Reaction of two different alkyl halide with sodium produces propane

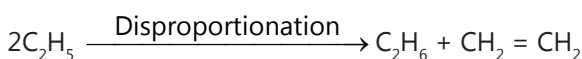
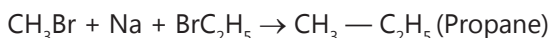
**2.2.3 Ullmann Reaction**

When an iodoarene is heated with Cu powder in a sealed tube, di-aryl is formed (proceeds via free-radical mechanism).

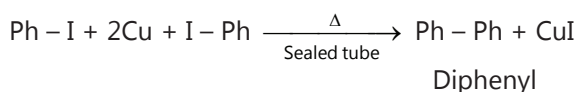
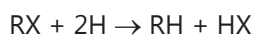
**2.2.4 Reduction of Alkyl Halide**

RX can be reduced by any one of the following reagents (which provide nascent H):

(i)  $\text{Zn} + \text{CH}_3\text{COOH}$  or  $\text{Zn} + \text{dil. HCl}$  or  $\text{Zn} + \text{NaOH}$

- (ii) (Zn + Cu) Couple + Ethanol (C<sub>2</sub>H<sub>5</sub>OH)
- (iii) LiAlH<sub>4</sub> (or LAH) + Ether (it reduces 1° and 2° RX to RH but 3° RX to alkene)
- (iv) Heating with Red P + HI at 420 K (or 150°C)
- (v) TPH [Triphenyl tin hydride (Ph<sub>3</sub>SnH)]
- (vi) NaBH<sub>4</sub> + C<sub>2</sub>H<sub>5</sub>OH (it reduces only 2° and 3° RX to RH not 1° RX)
- (vii) Mg + ether followed by H<sub>2</sub>O

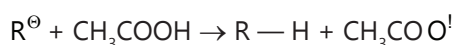
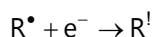
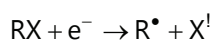
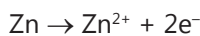

It is an e<sup>-</sup> transfer from metal to substrate followed by the addition of a proton from the solvent. Earlier it was considered that reduction is carried out by nascent hydrogen (H).

### Examples:

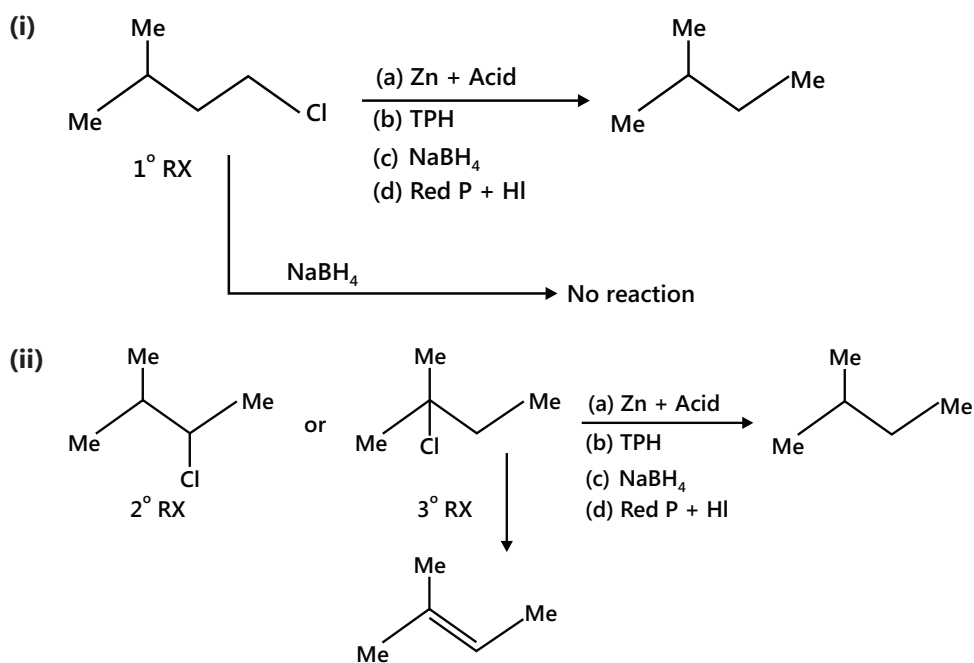

## 2.2.5 Frankland Reaction

When an alkyl halide is heated with zinc powder, a higher alkane is formed.

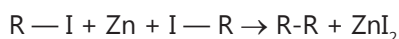

## 2.2.6 Corey House Synthesis

This reaction is used for the preparation of even, odd, symmetric and unsymmetrical alkanes.

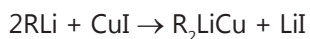
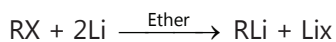

Dialkyl lithium cuprate

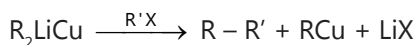

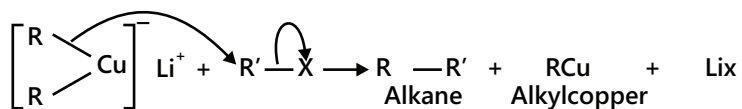
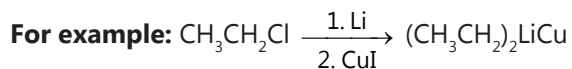

(Where R and R' may be same or different alkyl groups)

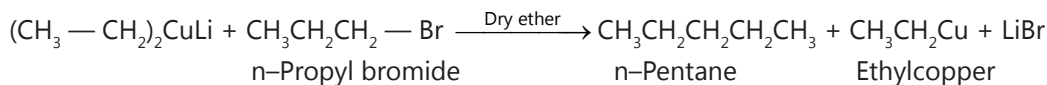
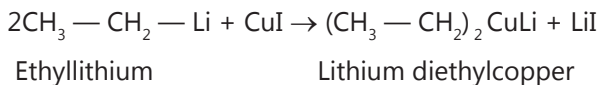
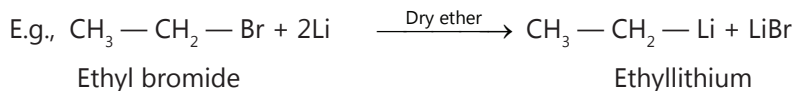

### Illustration 7:

(JEE MAIN)

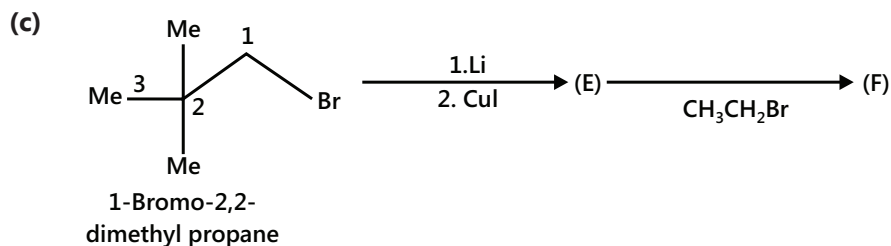
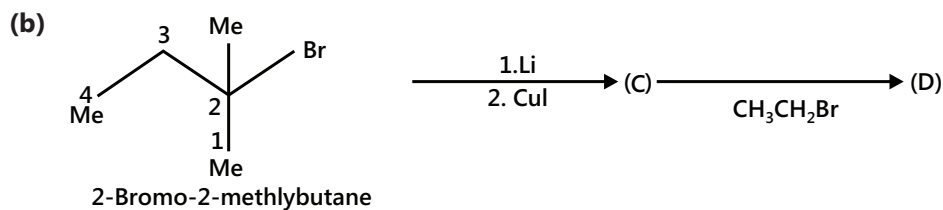
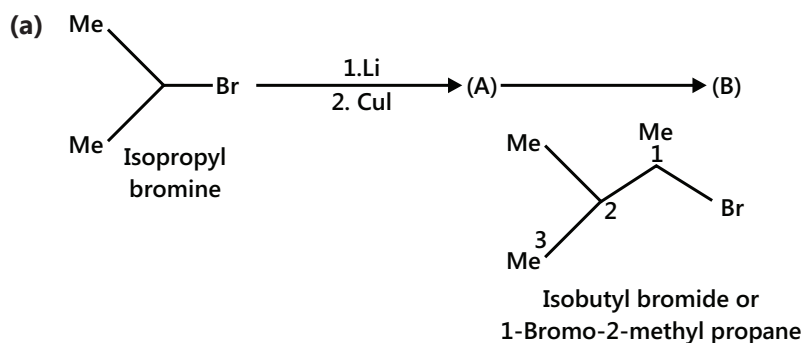

**Sol:**

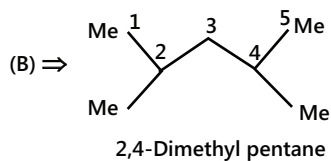
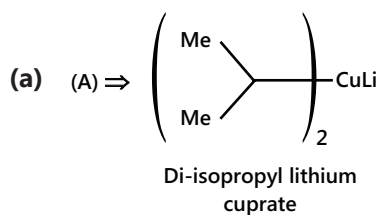

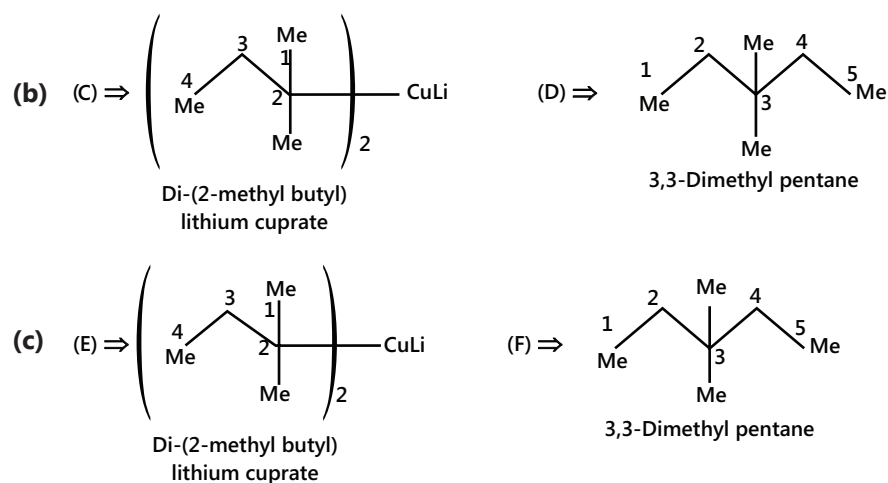

## 2.3 From Carboxylic Acids

### 2.3.1 Decarboxylation

The process by which a molecule of  $\text{CO}_2$  is removed from an organic compound, is called decarboxylation.

When a carboxylic acid is heated with soda-lime ( $\text{NaOH} + \text{CaO}$  in the ratio 3: 1) at about 630 K a molecule of  $\text{CO}_2$  is lost and an alkane with one carbon atom less than the carboxylic acid is formed.

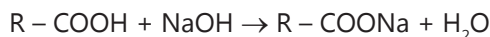

Carboxylic acid

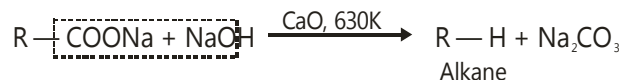

Ethanoic acid                      Sod. ethanoate  
(Acetic acid)

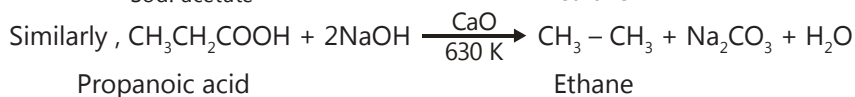
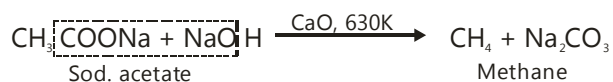

(Propionic acid)

$\text{NaOH}$  alone could have been used in the above reaction but soda-lime is preferred because of the following two reasons:

- (i)  $\text{CaO}$  permits the reaction to be carried out at a relatively higher temperature to ensure complete decarboxylation.
- (ii)  $\text{CaO}$  keeps  $\text{NaOH}$  dry because it is quite hygroscopic (absorbs moisture from air) in nature.

### 2.3.2 Kolbe's Electrolysis

The electrolysis of an aqueous solution of sodium or potassium salt of a fatty acid gives a higher alkane, and the electrolysis of an aqueous solution of the sodium or potassium salt of dibasic acid gives alkene, whereas the electrolysis of aqueous solution of sodium or potassium salt of dibasic unsaturated fatty acid gives alkyne.

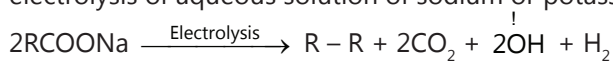

Mechanism (free radical)



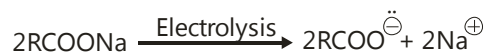

At anode (oxidation)

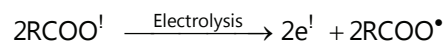

At cathode (reduction): Reduction of  $\text{H}_2\text{O}$  takes place since its reduction potential is greater than  $\text{Na}^{\oplus}$ .

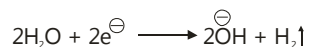

Methane cannot be prepared by this method.

### Some examples:

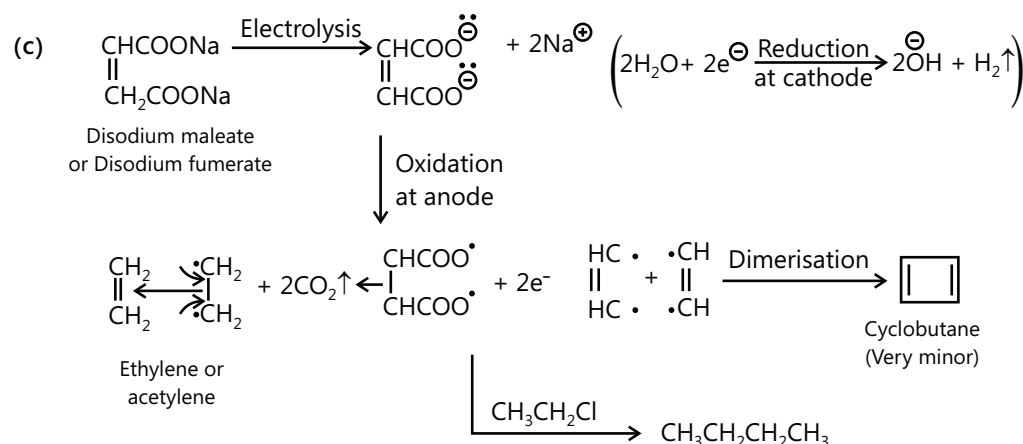
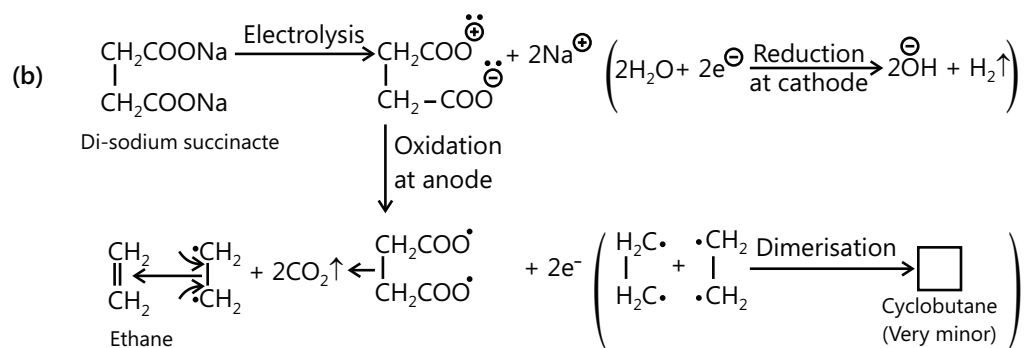
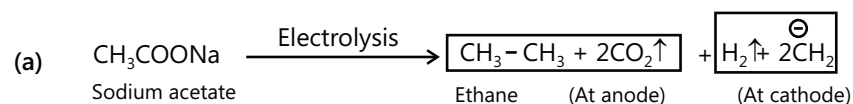

### 2.3.3 Reduction of Carbonyl compound to Alkane by Clemmenson's and Wolf Kishner's Reduction

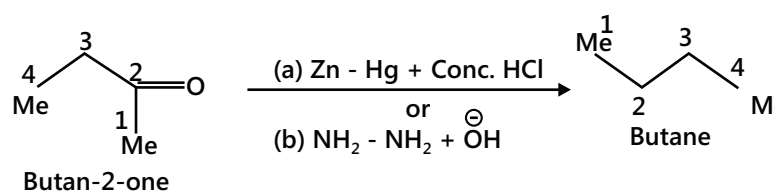

### 2.3.4 With HI and Red Phosphorus

Reduction of Acids and Carbonyl Compounds with red P + HI to Alkane

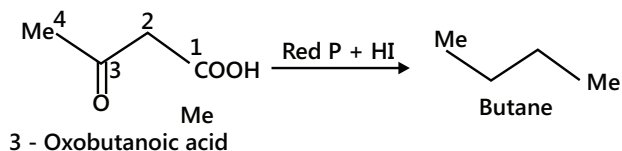

### 2.3.5 The Mozingo reduction

A chemical reaction capable of fully reducing a ketone or aldehyde to the corresponding alkane is called the Mozingo reaction or thioketal reaction. The reaction scheme is as follows:

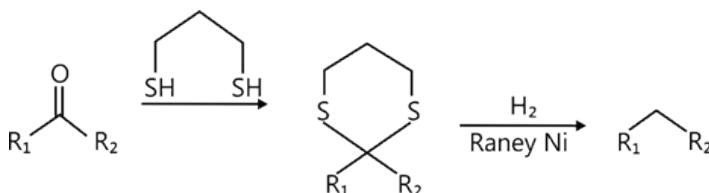

## 2.4 From Carbides

4. By the action of water on beryllium and aluminium carbide. Both these carbides on treatment with water yield methane.

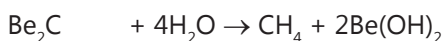

Beryllium carbide                      Methane

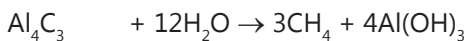

Aluminium carbide                      Methane

## 3. PROPERTIES OF ALKANES

- Boiling points:** In straight chain alkane C1 to C4 are gases, C5 to C17 are liquids and C18 onwards are colorless waxy solids. With increase in the molecular size the surface area increases and hence Vander-Waals forces increase which increases B.P. accordingly. B.P. of branched chain isomers are lower than corresponding n-alkanes due to decreased surface area.

$\text{CH}_3\text{CH}_2\text{CH}_2\text{CH}_2\text{CH}_3$	n-pentane	B.P.= 309.1K, m.p. 143.3K
$\text{CH}_3\text{CH}(\text{CH}_3)\text{CH}_2\text{CH}_3$	Iso-pentane	B.P.= 301K, m.p. 113.1K
$\text{CH}_3\text{C}(\text{CH}_3)_2\text{CH}_2\text{CH}_3$	Neo-pentane	B.P. 282.5, m.p. 256.14K

- Melting points:** Melting points of alkanes also increase with the increase in carbon content but the variation is not regular. Alkanes with even number of carbon atoms have higher m.p. than those with odd number of carbon atoms. This property is commonly known as the alternation effect.
- Solubility:** 'Like dissolves like' is the general rule of solubility. Non polar alkanes which are insoluble in polar solvents such as water, alcohol, etc. are highly soluble in non-polar solvents such as petroleum ether, benzene, carbon tetrachloride, etc. greases are mixtures of higher alkanes and hence are non-polar and hydrophobic (water repelling) in nature.
- Density:** The densities of alkanes increase with increase in the molecular masses till the limiting value of about  $0.8\text{g cm}^{-3}$ . This means that all alkanes are lighter than water.

**Illustration 8:** Arrange the compounds of (i) in the order of decreasing boiling points and (ii) in the order of decreasing solubility in water.

- (a) (1) Ethanol, (2) Propane, (3) Pentanol  
 (b) (1) Butane, (2) 1, 2, 3-Pentane triol, (3) Butyl alcohol  
 (c) (1) Pentane, (2) Pentanol, (3) Hexanol

**Sol: 8 (a) (i)** Alcohol has higher boiling point compared to alkane (of same molecular mass). Water is a polar solvent it will dissolve polar molecule.

The correct Decreasing order of boiling point is:

Pentanol > Ethanol > Propane (3 > 1 > 2).

Both Pentanol and ethanol have H-bonding, but Pentanol has higher molecular mass than ethanol, so it has high boiling point.

Propane has the least boiling point due to its non-polar character and weak Vander Waals forces of attraction.

**(ii)** The decreasing order of solubility in H<sub>2</sub>O is:

Ethanol > Pentanol > Propane (1 > 3 > 2).

Like dissolves like.

Since water is a polar solvent it will dissolve polar molecule.

Due to non-polar character of propane it is least soluble in water.

Solubility of ethanol and Methanol is explained as follows:

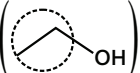
Both ethanol and Pentanol involves hydrogen bonding, but non-polar (Carbon chain) part  in Pentanol is larger than non-polar  part in ethanol. So ethanol is more soluble in H<sub>2</sub>O than Pentanol.

**(b) Methodology:** It is obvious that alcohol has higher boiling point compared to alkane (of same molecular mass). Water is a polar solvent it will dissolve polar molecule

**(i)** The correct order of decreasing boiling point is:

1, 2, 3-Pentane triol > Butyl Alcohol > Butane (2 > 3 > 1).

Due to three (OH) groups in compound (2), it has more H-bonding than in alcohol (3).

**(ii)** Decreasing solubility in H<sub>2</sub>O: (2) > (3) > (1).

Butane is least soluble. There is more H-bonding in compound (2) than in (3), hence it has more solubility in H<sub>2</sub>O.

**(c)** It is obvious that alcohol has higher boiling point compared to alkane (of same molecular mass). Water is a polar solvent it will dissolve polar molecule

**(i)** The decreasing order of boiling point is:

Hexanol > Pentanol > Pentane

(3 > 2 > 1)

In this case both the alcohols have same Hydrogen bonding, but molecular mass of Hexanol is higher than that of Pentanol. Hence, it has higher boiling point.

Pentane has low boiling point.

**(ii)** The decreasing order of solubility in H<sub>2</sub>O:

Pentanol > Hexanol > Pentane

**Illustration 9:** Arrange the following in the decreasing order of their boiling points.

- (a) (1)  $C_3H_8$ , (2)  $C_2H_5OH$ , (3)  $(CH_3)_2O$ , (4)  $HOH_2C-CH_2OH$   
 (b) (1) 3-Pentanol, (2) n-Pentane, (3) 2, 2-Dimethyl propanol, (4) n-Pentanol

**Sol:** It is obvious that alcohol has higher boiling point compared to alkane (of s same molecular mass).

(a) The decreasing order of boiling point is:

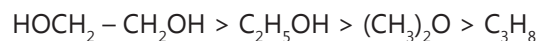

$$(4 > 2 > 3 > 1)$$

(Same explanation as I (B) (a) above)

(b) The decreasing order of boiling points is:

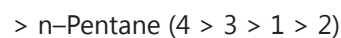
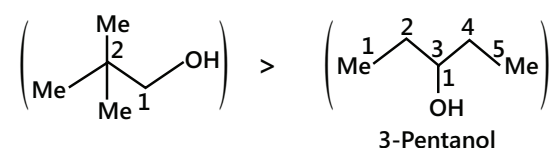
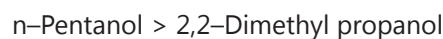

All the Alcohols (4), (3), and (1) have H-bonding, but n-pentanol is a straight chain compound and thus it has a large surface area, (so the highest boiling point).

Alcohol (3) is sterically hindered than alcohol (1), hence it requires more energy to boil off. Therefore, boiling point of alcohol (3) > alcohol (1).

## 4. REACTION OF ALKANES

### 4.1 Combustion

In sufficient oxygen, alkane gives water and carbon dioxide as products. The complete combustion reaction of butane is:

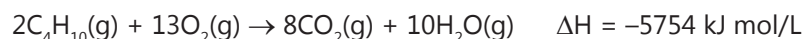

In general, the formula for complete combustion of alkanes is:

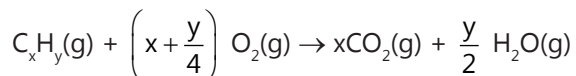

In insufficient supply of  $O_2$  by incomplete combustion, carbon monoxide and elemental carbon are formed. Incomplete combustion of octane:  $2C_8H_{18}(l) + 17O_2(g) \rightarrow 16CO(g) + 18H_2O(g)$

### 4.2 Substitution Reactions

#### 4.2.1 Halogenation

In this reaction, hydrogen of alkane is replaced by halogen. Reaction proceed by "Homolytic fission" in which free radicals are formed.

(i) Chlorination: During chlorination of methane, all the four hydrogen atoms are replaced one by one to form a mixture of products. For example,



Methane

Chloromethane

(Methyl chloride)



Chloromethane

Dichloromethane

(Methylene chloride)



Dichloromethane

Trichloromethane

(Chloroform)



Trichloromethane

Tetrachloromethane

(Carbon tetrachloride)

Let's look at the mechanism behind the substitution reaction of bromine reacting with methane.

**Initiation:** UV breaks the bond between  $\text{Br}_2$  leaving free radicals

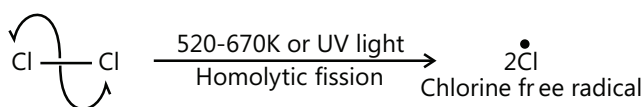
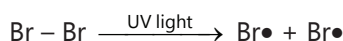

**Propagation:** Br reacts with methane, leaving another radical  $\text{CH}_3 - \text{Br}\cdot \longrightarrow \text{CH}_3\cdot + \text{HBr}$

(a) Propagation: The methyl radical reacts with another bromine molecule  $\text{CH}_3\cdot + \text{Br} - \text{Br} \longrightarrow \text{CH}_3\text{Br} + \text{Br}\cdot$

(b) **Chain propagation:** Each propagation step consists of two reactions. In the first reaction, the  $\text{Cl}\cdot$  radical attacks the  $\text{CH}_4$  molecule and abstracts a hydrogen atom forming  $\cdot\text{CH}_3$  and a molecule of  $\text{HCl}$  as shown reaction (i) in the second reaction,  $\cdot\text{CH}_3$  thus produced reacts further with a molecule of  $\text{Cl}_2$  forming a molecule of methyl chloride and another  $\cdot\text{Cl}$  as shown in reaction (ii). The newly formed  $\cdot\text{Cl}$  reacts with another molecule of  $\text{CH}_4$  (reaction (i)) to produce another molecule of  $\text{HCl}$  and another  $\cdot\text{CH}_3$ . This  $\cdot\text{CH}_3$  can again repeat reaction (ii) and so on. Thus, the sequence of reactions depicted in equations (i) and (ii) is repeated over and over again and the chain gets propagated. In other words, a single photon of light absorbed by  $\text{Cl}_2$  can bring about the conversion of a large number of  $\text{CH}_4$  molecules into  $\text{CH}_3\text{Cl}$ . Such reactions are called chain reactions.

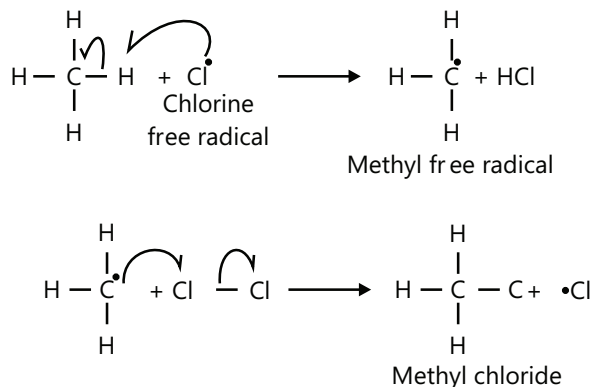

When sufficient amount of methyl chloride has been formed, the  $\cdot\text{Cl}$  produced in reaction (ii) has a greater chance of colliding with a molecule of  $\text{CH}_3\text{Cl}$  rather than a molecule of  $\text{CH}_4$ . If such a collision occurs, a new free radical ( $\cdot\text{CH}_2\text{Cl}$ ) is produced (reaction (iii)) which may subsequently react with  $\text{Cl}_2$  producing a molecule of  $\text{CH}_2\text{Cl}_2$  (reaction (iv)) and another  $\cdot\text{Cl}$ . This process continues till all the hydrogen atoms of methane are replaced by halogen atoms (reactions (v), (vi), (vii) and (viii)).

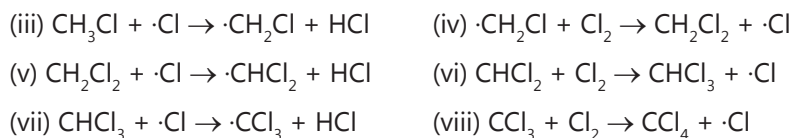

**Termination:** Two radicals react and complete the reaction \* Lots of Bromine will mean more substitution (dibromo, tribromo, etc.)

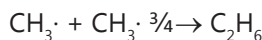
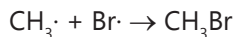
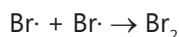

**Iodination:** Iodination of alkanes is generally not carried out to prepare RI as the reaction is highly endothermic and reversible. But is carried out in the presence of an oxidizing agent, such as  $\text{HIO}_3$ ,  $\text{HgO}$  and  $\text{HNO}_3$ , as it removes the HI formed in the reaction.

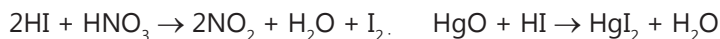
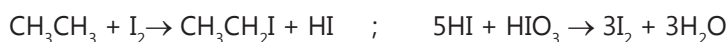

## PLANCESS CONCEPTS

The order of reactivity of different halogens in these reactions is:  $\text{F}_2 > \text{Cl}_2 > \text{Br}_2 > \text{I}_2$

However reaction with fluorine is very explosive and so never carried out.

**B Rajiv Reddy (JEE 2012, AIR 11)**

### 4.2.2 Nitration

**Nitration:** Replacement of a hydrogen atom by a nitro ( $-\text{NO}_2$ ) group is called nitration. At ordinary temperature, alkanes do not react with  $\text{HNO}_3$ . However, when a mixture of an alkane and fuming  $\text{HNO}_3$  vapours are heated at 423–673 K under pressure (vapour phase nitration), alkanes undergo nitration giving a mixture of nitroalkanes resulting through cleavage of carbon–carbon bonds. For example,



Methane (Fuming) Nitromethane (low yield)

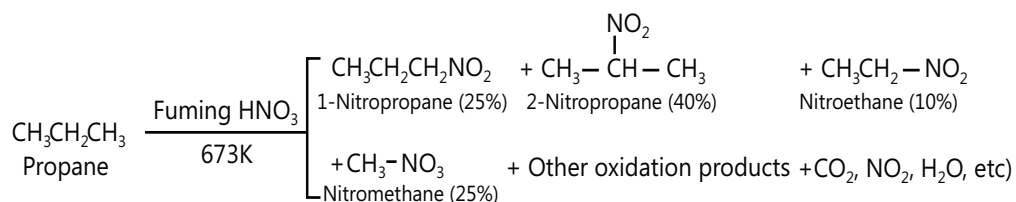
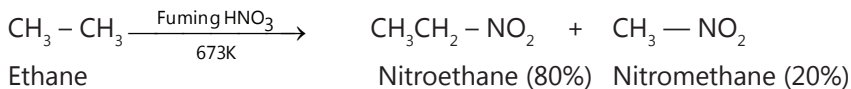

The order of reactivity of different hydrogens in this reaction is:  $3^\circ > 2^\circ > 1^\circ$ .

When nitration is carried out in vapour phase between 420K and 720K, a mixture of all possible mononitro derivatives is obtained (directly or after fission). For example,

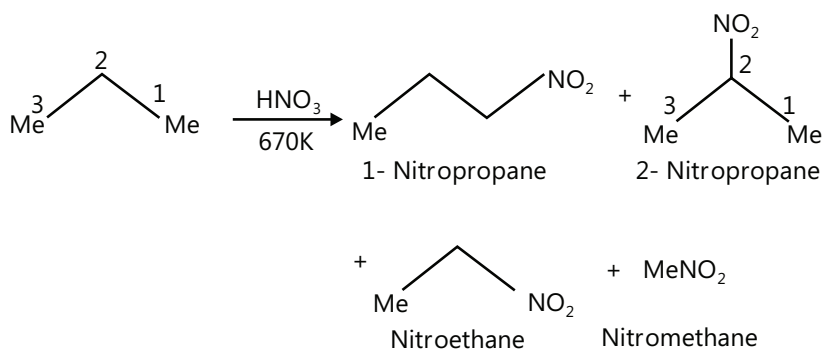

### 4.2.3 Sulphonation

When alkane is treated with oleum ( $\text{H}_2\text{S}_2\text{O}_7$ ) or fuming  $\text{H}_2\text{SO}_4$  ( $\text{H}_2\text{SO}_4 + \text{SO}_3$ ), H atom is replaced by ( $-\text{SO}_3\text{H}$ ) group. The order of reaction is  $3^\circ > 2^\circ > 1^\circ$ .

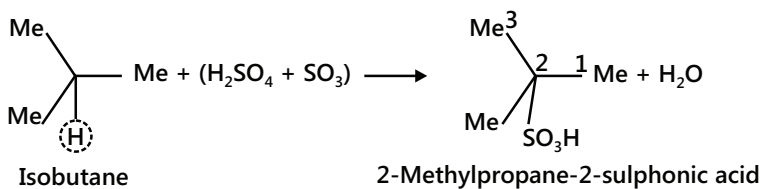

### 4.3 Catalytic oxidation

(i) When  $\text{CH}_4$  and  $\text{O}_2$  (9: 1) are heated at 100 atm pressure and passed through copper wires at 470K,  $\text{CH}_4$  is oxidized to  $\text{CH}_3\text{OH}$ .

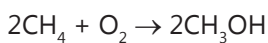

(ii)  $\text{CH}_4$  and  $\text{O}_2$ , when heated with molybdenum oxide, give methanal.

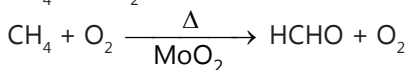

(iii) Higher alkane ( $\text{C}_{16}$ ) on oxidation with manganese acetate at 370–430 K produces higher fatty acids.

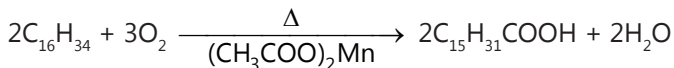

(iv) With alkaline  $\text{KMnO}_4$ ,  $3^\circ\text{H}$  atom is oxidized to ( $-\text{OH}$ ) group.

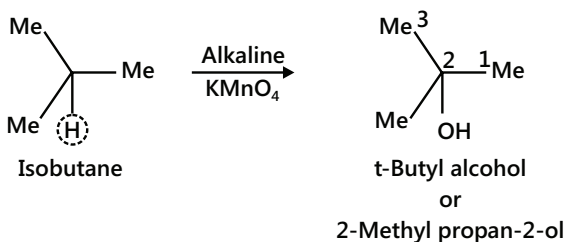

Because of the +I effect of the three  $\text{CH}_3$  groups,  $e^-$  density at  $3^\circ\text{C}$  atom is relatively high, which accounts for its easier oxidation.

(v) **Partial oxidation:** When  $\text{CH}_4$  and  $\text{C}_2\text{H}_6$  are treated with  $\text{O}_2$  at high pressure and low temperature, H atom changes to ( $-\text{OH}$ ) group, successively.

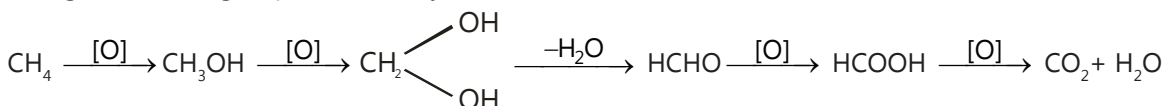

## 4.4 Isomerization

Alkanes on heating with  $\text{AlCl}_3$  at 570K isomerize to give branched-chain alkane [takes place via 1, 2  $\text{H}^\ominus$  (hydride) or Me shift]

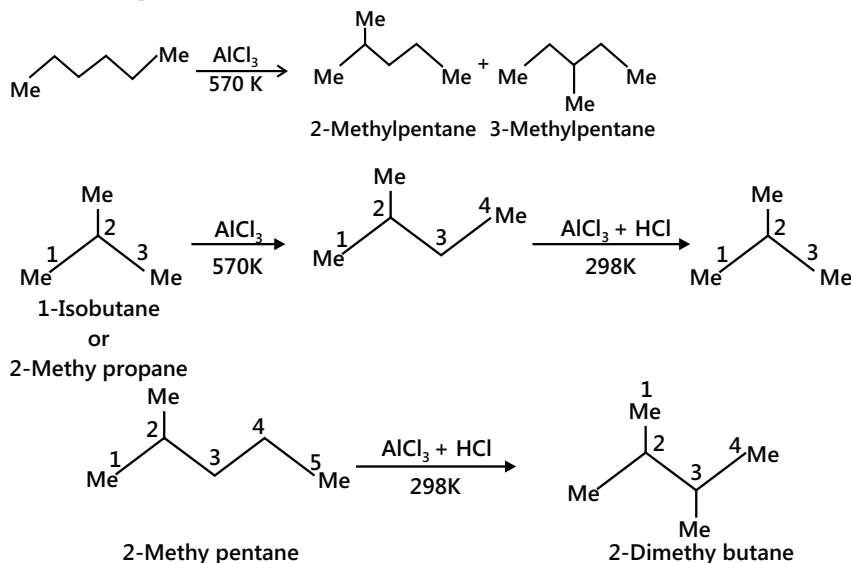

## 4.5 Aromatization

Alkanes containing six to eight carbon atoms when heated to about 773K under 10–20 atm pressure in the presence of a catalyst consisting of oxides of chromium, vanadium and molybdenum supported over alumina, get converted into aromatic hydrocarbons. This process which involves cyclization, isomerization and dehydrogenation is called aromatization. For example

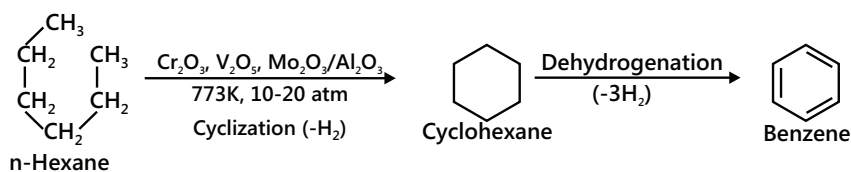

Under similar conditions, n-heptane gives toluene while n-octane gives a mixture of o-, m- and p-xylenes.

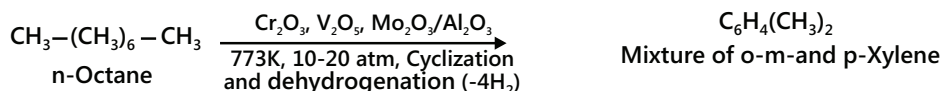
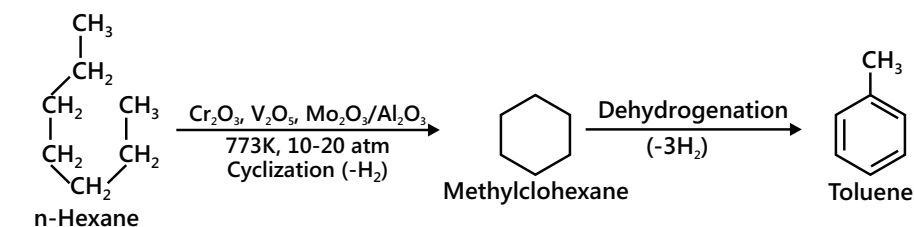

## 4.6 Pyrolysis

Pyrolysis of higher alkanes to give a mixture of lower alkanes, alkenes, etc. is called cracking. It is usually carried out by heating higher alkanes to high temperatures (773–973K) under a pressure of 6–7 atmospheres in presence or absence of a catalyst. For example

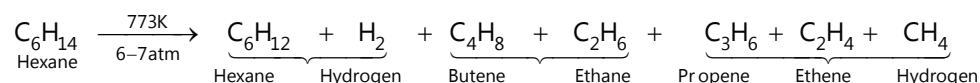



Pyrolysis of alkanes involves breaking of C – C and C – H bonds and occurs by a free radical mechanism. Preparation of oil gas from kerosene oil and petrol gas from petrol is based upon the process of pyrolysis. For example, dodecane, a constituent of kerosene oil, on heating to 973K in presence of Pt, Pd or Ni, gives a mixture of heptane and pentene along with other products.

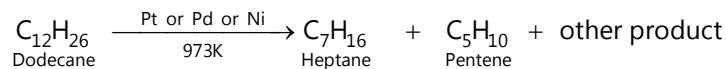

## 5. USES OF ALKANES

- (i) Methane in form of natural gas is used for running scooters, cars, buses, etc. LPG (a mixture of butane and isobutane) is used as a fuel in homes as well as in industry.
- (ii) Methane is used to make carbon black which is used in manufacture of printing inks, paints and automobile tyres.
- (iii) Catalytic oxidation of alkane gives alcohols, aldehydes and carboxylic acids.
- (iv) Higher alkanes in form of gasoline, kerosene oil, diesel, lubricating oils and paraffin wax are widely used.
- (v) Methane is used for the manufacture halogen containing compounds such as  $\text{CHCl}_3$ ,  $\text{CH}_2\text{Cl}_2$ ,  $\text{CCl}_4$ , etc. which are used as solvents both in laboratory and industry.

## 6. PETROLEUM

Petroleum is a dark viscous oily liquid. It is believed that it is formed by the decomposition of marine animals under pressure and temperature. Petroleum is found deep below the earth's crust, trapped within rock structures much below the seabed. Petroleum or crude oil is obtained in a complex mixture of hydrocarbons (chiefly aliphatic with small amount of aromatic hydrocarbons) along with small amount or organic compounds of sulphur and nitrogen.

S. No.	Fraction	Approximate composition	Boiling range (in K)	Uses
1.	Gaseous hydrocarbons	$\text{C}_1$ – $\text{C}_4$	Upto 303	As fuel gas after liquification and as carbon black.
2.	Crude naphtha 1. Petroleum 2. Petrol or gasoline 3. Benzene	$\text{C}_3$ – $\text{C}_{10}$ $\text{C}_5$ – $\text{C}_7$ $\text{C}_7$ – $\text{C}_9$ $\text{C}_9$ – $\text{C}_{10}$	303–423 303–363 363–393 393–423	As solvent in varnish and rubber industries, and for As motor fuel; for dry cleaning For dry cleaning
3.	Kerosene oil	$\text{C}_{10}$ – $\text{C}_{13}$	423–513	Fuel for stoves; in manufacture of oil gas as illuminant
4.	Fuel oil 1. Gas oil 2. Diesel oil 3. Furnace oil	$\text{C}_{13}$ – $\text{C}_{18}$	513–623	Fuel for diesel engine and tractors; in sizing paper.
5.	Lubricant oil 1. Medicinal oil 2. Motor oil 3. Grease	$\text{C}_{15}$ – $\text{C}_{18}$	Above 543	Paint oil; transformer oil, in lubrication; in sizing paper.
6.	Paraffin wax 1. Petroleum jelly 2. Petroleum wax 3. Petroleum coke	$\text{C}_{18}$ – $\text{C}_{30}$	673 upwards	Ointments, candles, paraffin wax, for matches, paints, water proofing solid fuel, protecting paints

7.	Heavy fuel oil and Bitumen	C <sub>30</sub> onwards	From residue	Paints; road surfacing
----	----------------------------	-------------------------	--------------	------------------------

## 6.1 Knocking

Knocking may be defined as the pre-ignition of fuel-air mixture in the cylinder ahead of the flame. It reduces the efficiency of the engine and also causes damage to the cylinder and piston of the engine.

1. The extent of knocking depends on the quality of the fuel used. In other words, a fuel that produces minimum knocking is considered as a good-quality fuel.
2. The anti-knocking property or the quality of a fuel is usually expressed in terms of the octane number.

## 6.2 Octane Number

Octane number is a scale that is used to determine the quality of a fuel.

It may be defined as the percentage of iso-octane by volume in the mixture of isooctane and n-heptane that has the same anti-knocking properties as the fuel under examination.

1. Straight-chain aliphatic hydrocarbons have a higher tendency to knock than branched-chain hydrocarbons.
2. Two pure hydrocarbons have been selected as standards;
  - a. n-Heptane has poor anti-knocking property, therefore, arbitrarily it has been assigned an octane number of zero.
  - b. 2, 2, 4-Trimethylpentane (isooctane), a branched-chain hydrocarbon, has the highest anti-knocking property. Therefore, it has been given the octane number of 100. The octane number of nonane is -45 and that of 2, 2, 3-trimethylpentane,

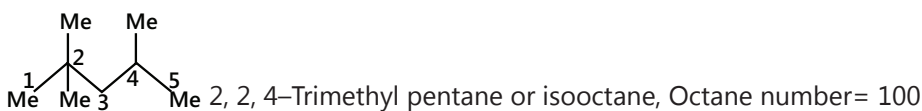
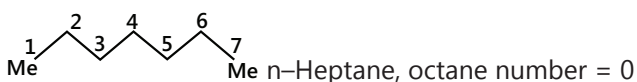
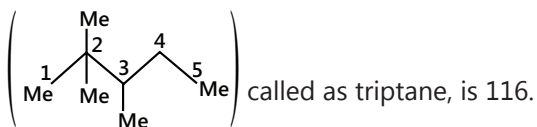

Alkanes	Octane number
CH <sub>4</sub>	122
C <sub>2</sub> H <sub>6</sub>	101
C <sub>3</sub> H <sub>8</sub>	96
C <sub>4</sub> H <sub>10</sub>	89

3. Straight-chain alkanes have very low octane numbers. As the length of the chain increases, the octane number decreases.
4. Branched-chain alkanes have higher octane numbers. As the branching increases, the octane number increases.
5. Cycloalkanes have higher octane numbers. As the extent of branching increases, octane number further increases.

The tendency of knocking decreases in the order.

Straight-chain alkane > branched-chain alkane > alkenes > cycloalkanes > aromatic hydrocarbon

### 6.3 Anti Knocking Agents

Compounds that are added to gasoline and reduce knocking are called anti-knocking agents. The best anti-knocking agent is tetraethyl lead (TEL) or  $\text{Pb}(\text{C}_2\text{H}_5)_4$ . This is added to the extent of 0.001% in gasoline. Such a gasoline is called ethyl gasoline we leaded gasoline.

In the cylinder of an engine, TEL decomposes to produce ethyl radicals that combine with the radicals produced due to irregular combustion. As a result, reaction chain is broken and smooth burning of the fuel occurs. This prevents knocking.  $\text{Pb}(\text{C}_2\text{H}_5)_4 \xrightarrow{\text{Heat}} \text{Pb} + 4\text{C}_2\text{H}_5$  (Ethyl radical)

The lead deposited in the cylinder is removed by adding 1, 2-dibromoethane (ethylene bromide) that decomposes into ethane (ethylene) and bromine. The bromine thus obtained combines with lead to form lead bromide which, being volatile, is carried off from the engine by exhaust gases.



### 6.4 Cetane Number

1. Cetane number is a scale that is used to determine the quality of diesel fuel. Cetane number is the percentage of cetane by volume in a mixture of cetane and  $\alpha$ -methyl naphthalene that has the same ignition properties as the diesel under examination in a test engine.

$\text{C}_{16}\text{H}_{34}$  (n-Hexadecane), cetane number = 10 (ignites spontaneously)

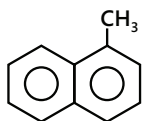

$\alpha$ -Methyl naphthalene, cetane number = 0 (ignites slowly) or 1-Methyl naphthalene

2. **LPG and CNG:** The term LPG (liquefied petroleum gas) refers to the mixture of hydrocarbons containing three or four C atoms. This includes propane ( $\text{C}_3\text{H}_8$ ), propene ( $\text{C}_3\text{H}_6$ ), n-butane ( $\text{C}_4\text{H}_{10}$ ), isobutene (methylpropane), and various butanes with a little amount of ethane ( $\text{C}_2\text{H}_6$ ). The major sources of LPG are natural gas, refining and cracking of petroleum. Alkenes are mainly produced during cracking. LPG is mainly used in the manufacturing of chemicals, as a fuel for households, and in the petro-chemical industry.

CNG (compressed natural gas) is a highly compressed form of natural gas. Many vehicles are designed to operate on CNG. Natural gas has an octane rating of 130.

**Illustration 10:** A sample of diesel has the same characteristics as a 60 mL mixture of cetane and  $\alpha$ -methyl naphthalene mixed in 2: 1 ratio (v/v). What is the cetane number of the diesel sample?

**Sol:** 60 mL of a mixture contains 40 mL cetane and 20 mL of  $\alpha$ -methyl naphthalene.

$$\text{Therefore, cetane number} = \frac{40 \times 100}{60} = 66.6\%$$

**Illustration 11:** Give the decreasing order of octane rating of the following:

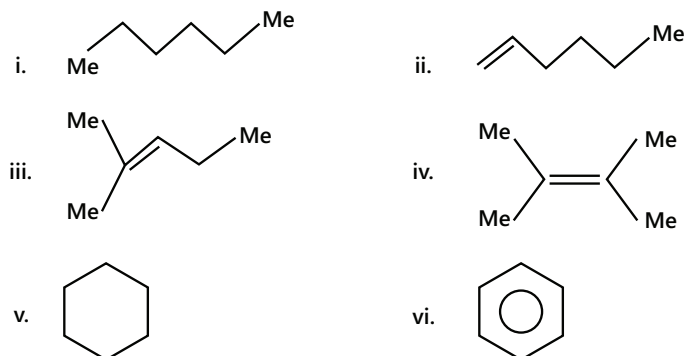

**Sol:** The tendency of knocking in the decreasing order is: Straight-chain alkane > branched-chain alkane > alkenes > cyclo alkane > aromatic hydrocarbons. The octane rating is in the reverse order as that of knocking tendency:

(vi) > (v) > (iv) > (iii) > (ii) > (i)

## 7. CYCLOALKANES

### 7.1 Nomenclature

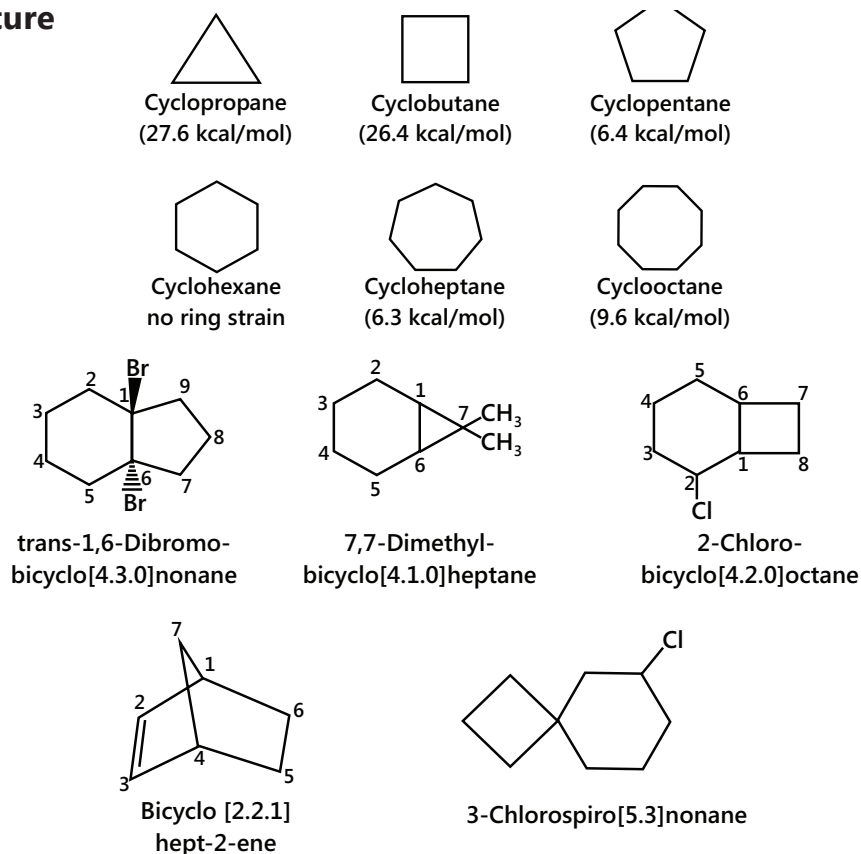

**Figure: 10.4** Nomenclature of fused cycloalkane

### The energy change in the ring-flip of cyclohexane (chair chair)

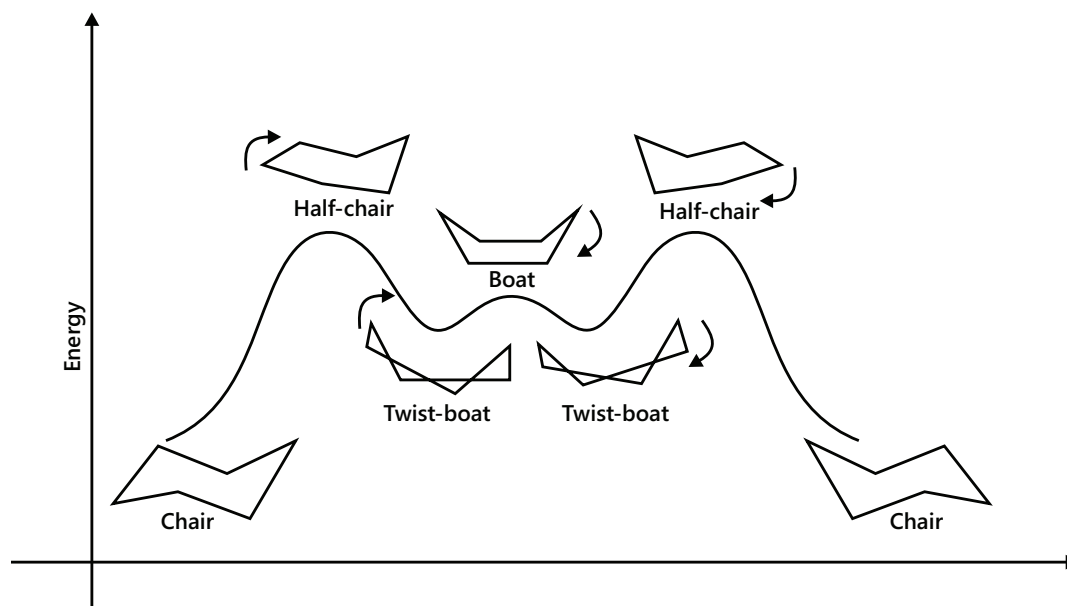

**Figure: 10.5** Stability of different conformers of cyclohexane

**Illustration 12:** Give IUPAC name of the following compounds:

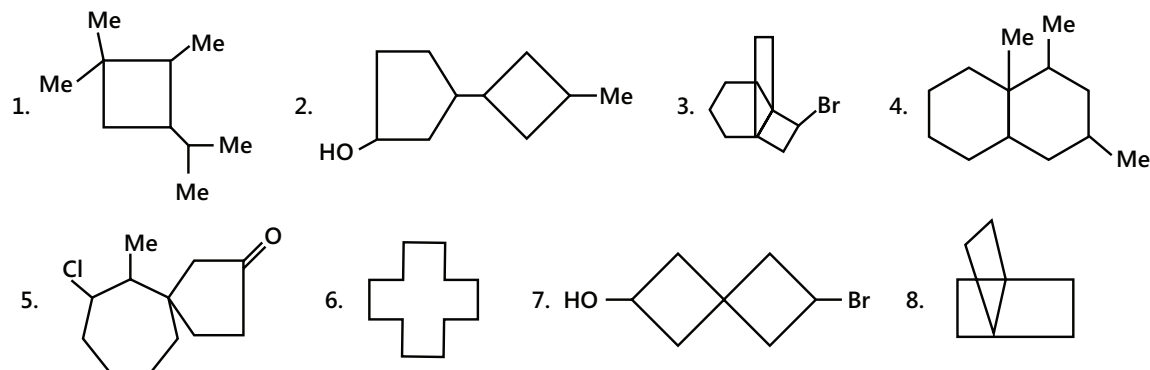

**Note:** The superscripts 1, 6 indicate the fused C atoms.

1. 1,2-trimethyl-3-isopropylcyclobutane.

2. (3-methylcyclobutyl) cyclopentanol.

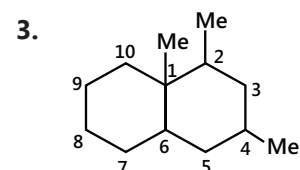

a. 1, 2, 4-Trimethyl bicyclo [4.4.0<sup>1,6</sup>] decane.

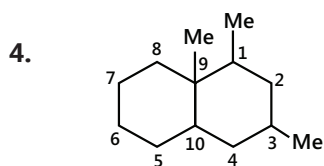

a. 1, 3, 9-Trimethyldecalin

b. Bicyclo compound

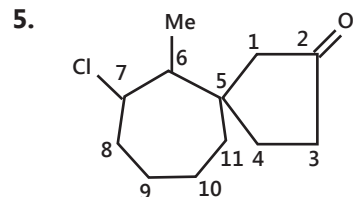

a. Spiro 7-chloro-6-methyl [6.4] undecan-2-one

or

7-chloro-6-methyl [4.6] undecan-2-one

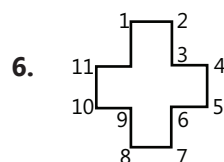

a. Cyclododecane

b. Monocyclic compound

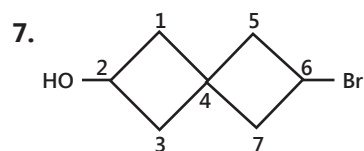

a. 6-Bromospiro [3.3] hexan-2-ol

b. Spiro compound

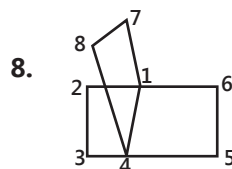

a. Tricyclo [2.2.2.0<sup>1,4</sup>] octane

b. Tricyclo compound

## 7.2 Physical Properties of Cycloalkanes

- Lighter than water, non-polar, soluble in organic solvents such as alcohol and ether.
- M.P and B.P. are higher than corresponding alkanes because of their compact shape.
- Carbon hydrogen bond is shorter than corresponding alkanes. Cycloalkanes are more acidic than corresponding alkanes, e.g., cyclopropane is more acidic than propane, because (C – H) bonds of cyclopropane have more s character in hybrid orbital used by C to form a bond.

**Stability of cyclohexane:** Cyclohexane exists in three non-planar or puckered conformations, called chair, twist boat, and boat forms.

In the chair form, all the (C – H) bonds on the adjacent carbons are in the skew position. In the boat form, there are four skew interactions (1, 2; 3, 4; 4, 5 and 6, 1) and two eclipsed interactions (2, 3 and 5, 6). At the same time, there is some bond opposition strain for these two pairs of eclipsed bonds (2, 3 and 5, 6) and also steric repulsion between the flagpole (fp) hydrogens (at 1 and 4), which are 1.83Å or 183 pm apart. Hence, the total strain in the boat conformations is larger than that in the chair conformation and therefore, the chair form is more stable than boat form.

## PLANCESS CONCEPTS

Stability order: Chair > Twist boat > Boat > Half chair

In substituted cyclohexane, the more stable form is the one in which the bulkier group is present at e(equatorial) position, since (e) bonds are away from the ring and hence have less or no steric hindrance than a (axial bonds). The examples are as follows.

a. The stable form of methyl cyclohexane is that in which methyl group is one(equatorial) position. There are two conformational isomers e.g.,

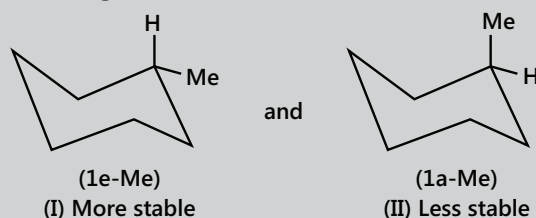

b. The stable form of cis-1, 2-dimethylcyclohexane is (1a, 2e) or (1e, 2a). There is one conformational isomer.

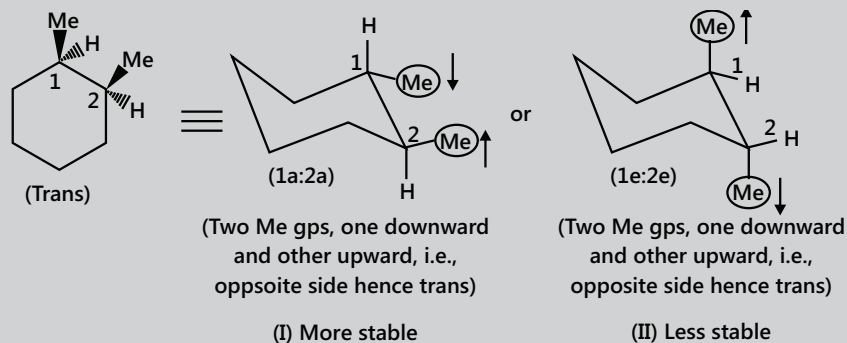

c. The stable form of trans-1, 2-dimethylcyclohexane is (1e: 2e). Two conformational isomers are as below:

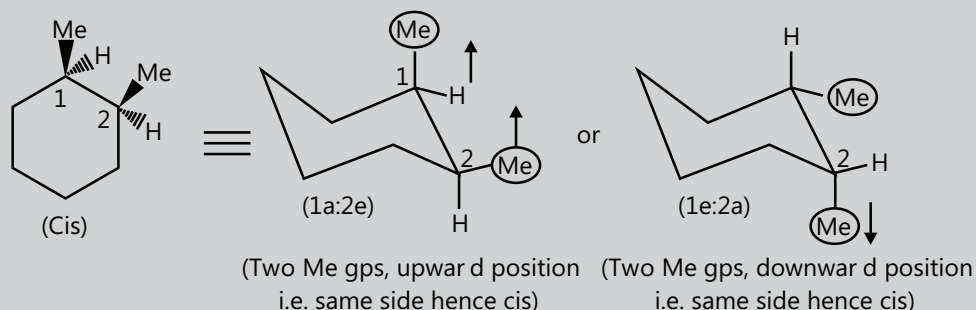

## 7.3 Reaction of Cycloalkanes

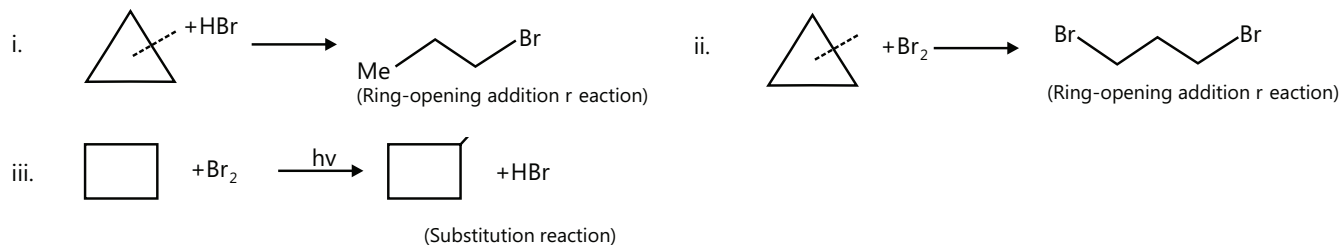

## POINTS TO REMEMBER

## Preparation of Alkanes:

From alkyl halide :

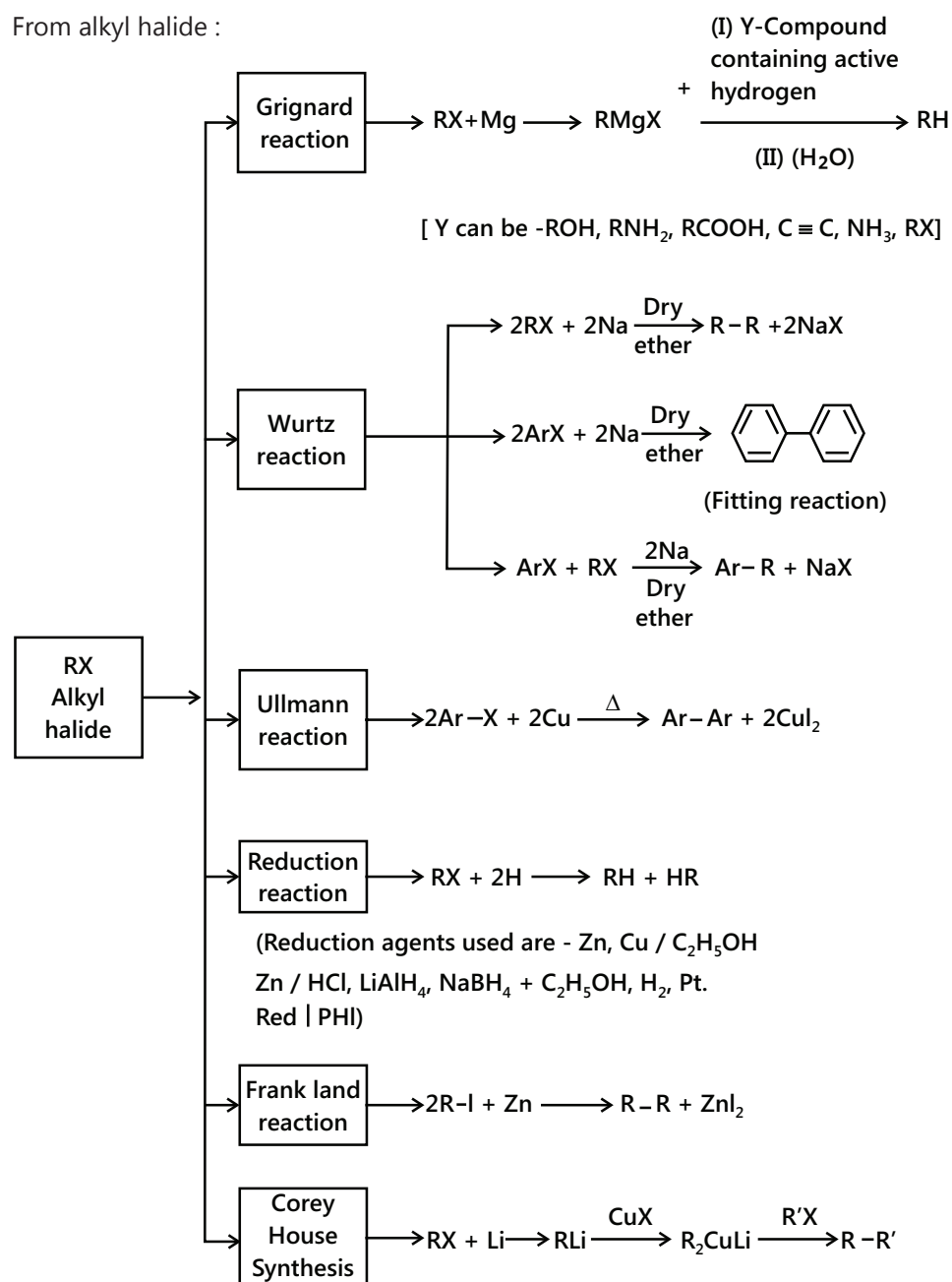

From **Alkene or Alkyne** by catalytic hydrogenation.

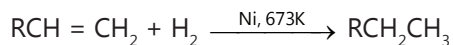

From **sodium salt of carboxylic acid**.

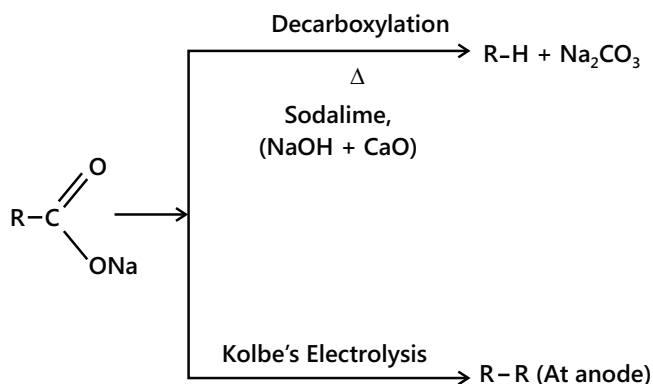

By reduction of carbonyl compounds :

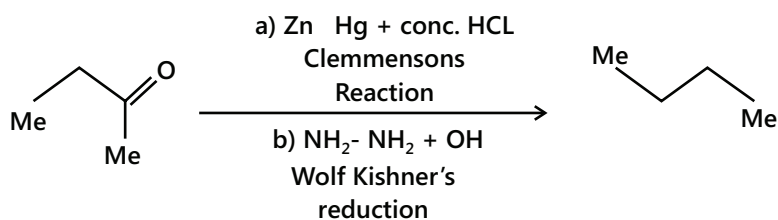

By reduction of acid and carbonyl compounds with Red P + HI

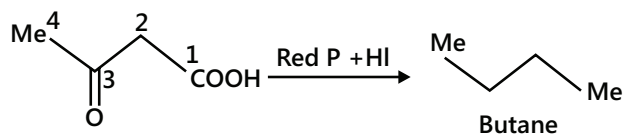

3-Oxobutanoic acid

### Properties

- For straight line hydrocarbons, the boiling point increases as the number of carbon atom increases, (Surface area increases thus Vander Waal force of attraction increases)
- For isomers as the branching increases, boiling point decreases. (Surface area decreases)
- 'Like dissolves like' is the general rule of solubility. As alkanes have non polar character they are soluble in non-polar solvents.
- The densities of alkanes increase with the increase in the molecular masses, they are lighter than water.



## Reactions of Alkane:

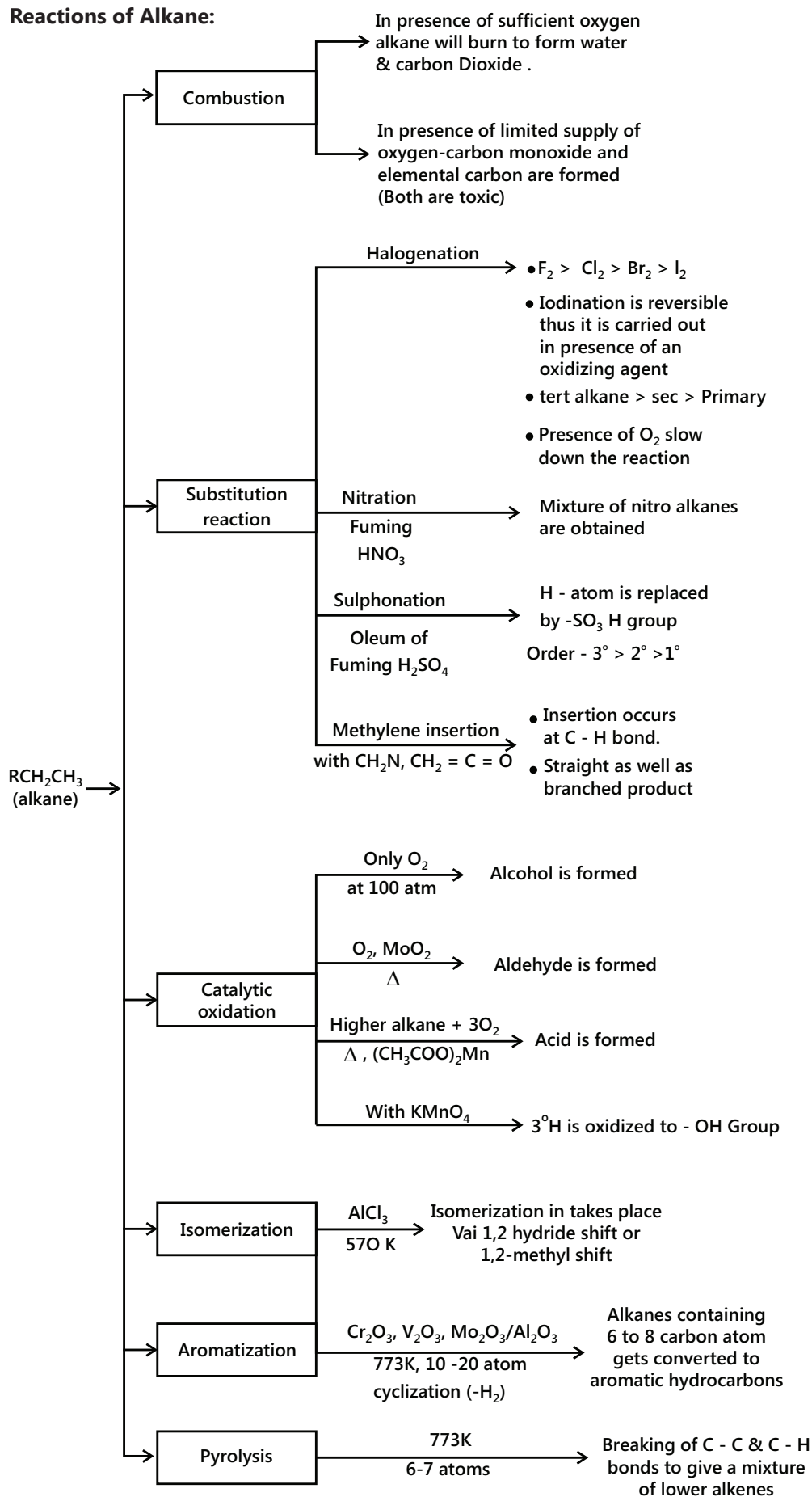

**Hydrocarbons :**

- The main sources of hydrocarbons are coal, petroleum and natural gas.
- Coal is the major source of aromatic hydrocarbons whereas petroleum is for aliphatic ones.

**Fraction of destructive distillation of coal :**

1	Light oil	Benzene, Toluene, Xylene
2	Middle oil	Naphthalene, Phenols and Cresols
3	Heavy oil	Naphthol, Cresols
4	Green oil	Anthracene, Phenanthrene
4	Pitch	Anthracene, Phenanthrene carbon

**Fractional distillation of petroleum gives following fractions:**

1	Petroleum gas	C <sub>1</sub> to C <sub>4</sub>
2	Petroleum ether	C <sub>5</sub> to C <sub>7</sub>
3	Gasoline	C <sub>12</sub> to C <sub>15</sub>
4	Kerosene	C <sub>12</sub> to C <sub>15</sub>
5	Gas oil, fuel oil, Diesel oil	C <sub>15</sub> to C <sub>1</sub>
6	Lubricating oil	C <sub>16</sub> onwards
7	Paraffin wax	C <sub>20</sub> onwards

**Cracking:** Thermal decomposition of higher hydrocarbons into lower ones. This can be in the vapour phase, thermal, steam, liquid phase etc.

**Reforming or Platforming:** The process of converting, aliphatic or alicyclic hydrocarbons into aromatic hydrocarbons in the presence of suitable catalyst like Pt, Pd or Ni.



**Octane number:** The percentage by volume of isooctane in a mixture of isooctane and n-heptane that has the same knocking value as the fuel under test.

Branched chain, cyclic, unsaturated and aromatic Hydrocarbons have higher octane number.

Fuel	Octane number
------	---------------

N-heptane	Zero
-----------	------

2,2,4 trimethylpentane	100
------------------------	-----

2,2,3 trimethylpentane	116
------------------------	-----

(triptane)

**Cetane number:** The percentage volume of cetane in a mixture of cetane and α-methyl naphthalene that has the same initiation quality as the fuel under investigation is known as cetane number.